

Science Focus 4

second edition

Greg Rickard
Nici Burger
Warrick Clarke
Janette Ellis
David Geelan
Faye Jeffery
Carol Neville
Geoff Phillips
Peter Roberson
Cherine Spirou
Kerry Whalley

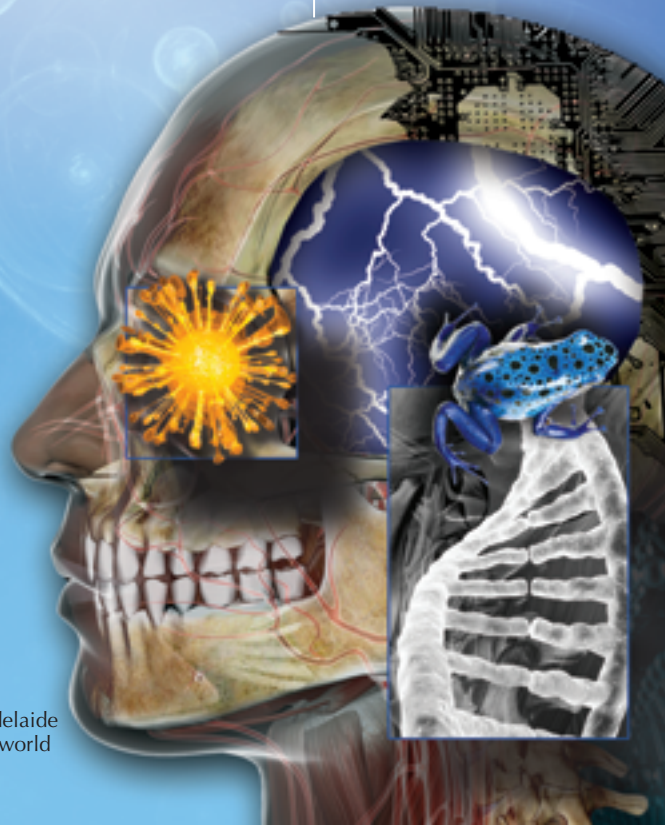

PEARSON
Heinemann

Sydney, Melbourne, Brisbane, Perth, Adelaide
and associated companies around the world

Contents

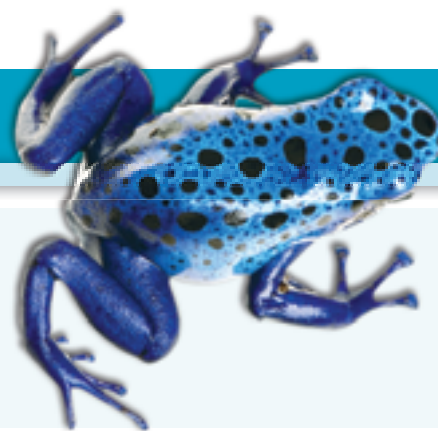

Acknowledgements	v
Series features	vi
How to use this book	viii
Stage 5 Syllabus Correlation	x
Verbs	xi

CHAPTER 1



Chemical and nuclear reactions 1

Unit 1.1 Chemical reactions	2
Unit 1.2 Corrosion and oxidation	16
Unit 1.3 Nuclear reactions and radiation	25
Chapter review	34

CHAPTER 2



Materials 35

Unit 2.1 Pure metals and alloys	36
Unit 2.2 Mining and extracting metals	43
Unit 2.3 Plastics	54
Unit 2.4 Fibres	63
Science focus: Organic chemistry	69
Unit 2.5 Soap	73
Chapter review	78

CHAPTER 3



Genetics 79

Unit 3.1 Inheritance	80
Unit 3.2 Human inheritance	92
Unit 3.3 The molecule of life	101
Unit 3.4 Controlling genetics	108
Science focus: DNA fingerprinting	115
Chapter review	120

CHAPTER 4



Health and disease 122

Unit 4.1 Health	123
Science focus: Aboriginal health	129
Unit 4.2 Disease	131
Unit 4.3 Infectious diseases	135
Unit 4.4 Transmission and control of infectious diseases	144
Unit 4.5 Non-infectious diseases	155
Chapter review	166

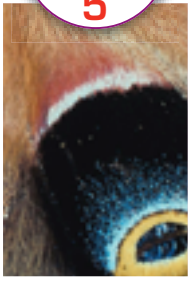
**CHAPTER
5****Evolution****167**

Unit 5.1	Being suited to your environment	168
Unit 5.2	Evolution through natural selection	172
Unit 5.3	Evidence for evolution	180
Unit 5.4	Human evolution	189
	Science focus: Evolution of a theory	196
	Chapter review	203

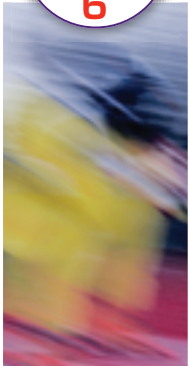
**CHAPTER
6****Motion****205**

Unit 6.1	Describing motion	206
Unit 6.2	Acceleration	218
Unit 6.3	Newton's First Law	224
Unit 6.4	Newton's Second Law	231
Unit 6.5	Newton's Third Law	236
Unit 6.6	Gravity	241
Unit 6.7	Work and energy	247
	Chapter review	254

**CHAPTER
7****Electricity, electromagnetism and communications technology****256**

Unit 7.1	Electricity	257
Unit 7.2	Electromagnetism	266
Unit 7.3	Waves in communication	277
Unit 7.4	The communications network	286
	Chapter review	292

**CHAPTER
8****Global issues****294**

Unit 8.1	Debates in science and society	295
Unit 8.2	Global warming	299
Unit 8.3	Nuclear power	309
Unit 8.4	Fiddling with food	317
Unit 8.5	Biotechnology	325
	Chapter review	330

**CHAPTER
9****Individual research project****331**

Unit 9.1	Being an individual	332
	Science focus: Weird science!	336
Unit 9.2	My investigation	339
	Science focus: Scientific method	342
	Chapter review	346

Sci Q Busters**348**

	Index	352
--	-------	-----

Acknowledgements

We would like to thank the following for permission to reproduce photographs, texts and illustrations. The following abbreviations are used in this list: t = top, b = bottom, c = centre, l = left, r = right.

ANSTO: p. 312t.

Australian Associated Press Pty Ltd: pp. 96t, 132l, 295t, 304, 313b, 319c.

Australian Radiation Protection and Nuclear Safety Agency: p. 313t.

Corbis Australia Pty Ltd: pp. 17t, 47, 58t, 64b, 92br, 129l, 130, 150b, 156b, 161, 174l, 180l, 194, 277, 286, 319r, 341.

CSIRO Publishing: p. 303.

Dorling Kindersley: p. 43b.

Doug Thost Photography: p. 299.

Dreamstime: pp. 72, 137b, 336r.

Emerald City Images/Minden Images: p. 177tr.

Getty Images Australia Pty Ltd: pp. cover, 45(B), 45t, 54, 64t, 79, 82(woman), 92tl, 104t, 125r, 168, 181tr, 189tr, 208l, 232b, 237b, 317b, 319l, 326, 334b.

Greg Rickard: pp. 18, 37tr, 38, 206b.

iStock: pp. 16l, 39r, 39tl, 80tl, 169tr, 177br, 222, 241t, 287bl, 301t, 309, 331.

John Fairfax Publications: pp. 71l, 212, 321b.

Jupiterimages Corporation © 2009: pp. 168l, 169br, 169cr, 189bl, 196.

NASA: pp. 28(solar), 300.

News Ltd/Newspix: pp. 55r, 66l; Toby Zerna: p. 207.

Pearson Australia: p. 70tr; Alice McBroom: p. 337l; Michelle Jellett: pp. 73b, 77, 125l.

Photolibary Pty Ltd: 1, 2tl, 6, 9bl, 9tr, 16r, 25, 26, 28(manufactured), 28(terrestrial), 29-31, 43t, 45(C), 46, 58b, 63, 66r, 80br, 82(chromosomes), 82br, 86, 95, 96b, 102l, 104bl, 104br, 108-110, 115, 116, 119, 122, 123tr, 124, 131br, 131t, 132r, 135-140, 144, 145, 147, 148br, 148t, 149, 150t, 151, 155, 156t, 157br, 157tr, 158, 159, 162b, 163, 168br, 170b, 173, 174r, 180br, 180tr, 181bl, 181br, 181cl, 182, 183t, 191-193, 197-200, 205, 208r, 219b, 224-226, 232t, 237t, 241b, 242, 248, 249, 258, 266, 270, 280br, 280t, 294, 295b, 297br, 301b, 305, 310, 312b, 314, 317t, 318b, 320, 321t, 322t, 325, 328, 332, 334t, 337r, 339, 340r, 343.

Picture Media/Reuters: p. 247t.

Shutterstock: pp. cover, 2br, 8, 9br, 9tl, 17cr, 28(medical), 35, 39bl, 55l, 65r, 69(family), 69(sheep), 69(tree), 73t, 94, 123bl, 129r, 131bl, 146, 148bl, 157tl, 162t, 219t, 236, 247b, 256, 257, 260, 318t, 322b, 327, 336l, 340(berries), 340(sunglasses), 340(tongue), 348-351.

The Picture Source: p. 65tl.

Every effort has been made to trace and acknowledge copyright. However, should any infringement have occurred, the publishers tender their apologies and invite copyright owners to contact them.

The **Science Focus Second Edition** series has been designed for the revised NSW Science Syllabus, Stages 4 and 5. This fresh and engaging series is based on the essential and additional content.

Student books with student CD

The student book consists of chapters with the following features:

- A science **context** at the beginning of each chapter encourages students to make meaning of science in terms of their everyday experiences.
- **Science Clip** boxes contain quirky and fascinating science facts and provide opportunity for further exploration by students.
- **Unit** and **chapter review questions** are structured around Bloom's Taxonomy of Cognitive Processes. Questions incorporate the key verbs, so that students can begin to practise answering questions as required in later years.
- **Investigating** sections incorporate ICT and research skills. These tasks are designed to push students to apply the knowledge and skills they have developed within the chapter.
- **Practical activities** are placed at the end of each unit to allow teachers to choose when and how to incorporate the practical work.
- **Science Focus spreads** use a contextual approach to focus on the outcomes of the prescribed focus area. Student activities on these pages allow for further investigation into the material covered.

Each student book includes an interactive student CD containing:

- an electronic version of the student book
- a link to Pearson Places for extensive online content.

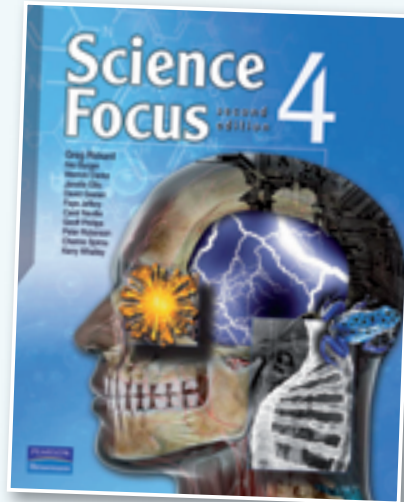

Homework books



The homework book has a fresh new design and layout and provides the following features:

- A **syllabus correlation grid** links each worksheet to the NSW Science Syllabus.
- Updated **worksheets** cover consolidation, extension and revision activities with explicit use of syllabus verbs so that students can begin to practise answering questions as required in later years.
- Questions are clearly graded within each worksheet, allowing students to move from lower-order questions to higher-order questions.
- A **crossword** for every chapter spans across a double-page spread so students can easily read the clues and instructions.
- **Sci-words** are listed for each chapter in an easy-to-follow tabulated layout.

Teacher editions (including teacher edition CD and student CD)



The innovative teacher edition contains a wealth of support material and allows a teacher to approach the teaching and learning of science with confidence. Teacher editions are available for each student book in the series. Teacher editions include the following features:

pages from the student book with **wrap-around teacher notes** covering the learning focus, outcomes and a pre-quiz for every chapter opening

approximately 10 different **learning strategies** per unit in addition to the activities provided in each unit of the student book

assessment ideas

answers to student book questions

practical activity support including a safety spot, common mistakes, possible results and suggested answers to practical activity questions

Teacher Resource boxes highlighting additional resources available, such as worksheets, online activities and practical activities.

Each **Science Focus Second Edition Teacher Edition CD** includes:

student book answers

homework book answers

chapter tests and answers

curriculum grids

teaching program for each chapter

student risk assessments

lab technician risk assessments

safety notes

lab technician checklist and recipes.



Pearson Places

www.pearsonplaces.com.au

Pearson Places is the online destination that is constantly evolving to give you the most up-to-date educational content on the Web. Visit **Pearson Places** to access educational content, download lesson material, use rich media and connect with students, educators and professionals around Australia.



- **Pearson Reader**
More than an eBook, Pearson Reader provides unique online student books that allow teachers and students to harness the collective intelligence of all who participate. Search for a unit of work and contribute by adding links and sharing resources.
- **Student Lounge**
One location for student support material—interactives, animations, revision questions and more!
- **Teacher Lounge**
One location for teacher support material—curriculum grids, chapter tests and more!



LiveText™ DVD

The LiveText™ DVD is designed for use with an interactive whiteboard or data projector. It consists of an electronic version of the student book with component links, some of which are unique to LiveText™. The features include one-touch zoom and annotation tools that allow teachers to customise lessons for students.

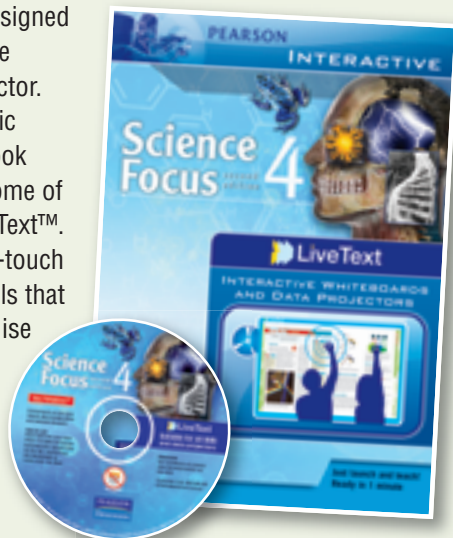

For more information on the **Science Focus Second Edition** series, visit the Bookstore at:
www.pearsonplaces.com.au

Science is a fascinating, informative and enjoyable subject. Science encourages us to ask questions and helps us understand why things happen in our daily lives, on planet Earth and beyond. Scientific knowledge is constantly evolving and challenges us to think about the world in which we live. Science shows us what we knew, what we now know and helps us make informed decisions for our future.

Science Focus 4 Second Edition has been designed for the revised NSW Science Syllabus. It includes material that addresses the learning outcomes in the domains of knowledge, understanding and skills. Each chapter addresses at least one prescribed focus area in detail. The content is presented through many varied contexts to engage students in seeing the relationship between science and their everyday lives.

The student book consists of nine chapters with the following features:

Chapter opener

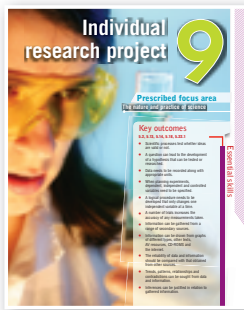

The key **prescribed focus area** addressed within the chapter is clearly emphasised.

The **learning outcomes** relevant to the chapter are clearly listed.

A clear distinction between **essential** and **additional** outcomes is presented in student-friendly language.

creating questions. Questions incorporate a variety of verbs, including the syllabus verbs. All verbs have been bolded so students can begin to practise answering questions as required in examinations in later years.

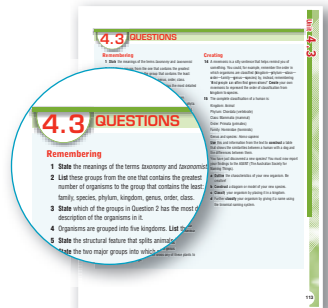

Units

Context

The **context** section appears at the beginning of each unit to encourage students to make meaning of science in terms of their everyday experiences.

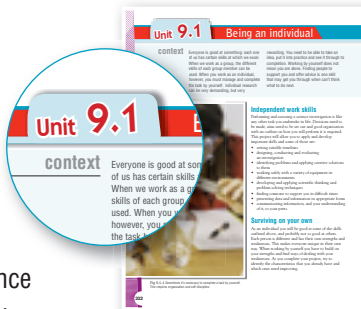

Investigating

The **investigating** activities can be set for further exploration and assignment work. These activities may also include a variety of structured tasks that fall under the headings of **reviewing** and **e-xploring**.



Unit content

The unit includes illustrations, photos and content to keep students engaged and challenged as they learn about science. A **homework book icon** appears within the unit indicating a related worksheet from the supporting homework book.



Practical activities

Practical activities are placed at the end of each unit, allowing teachers to choose when and how to best incorporate practical work into the teaching and learning. A **practical activity icon** will appear throughout the unit to signal suggested times for practical work. Within some practical activities a safety box appears that lists very important safety information. Some practical activities are **design your own** (DYO) tasks and others may be conducted using a **data logger**. Icons are inserted to indicate these options.

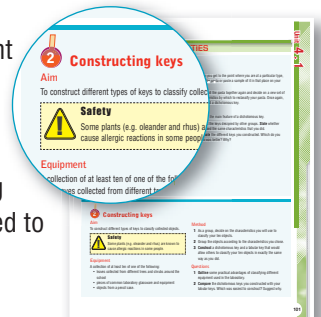

Chapter review

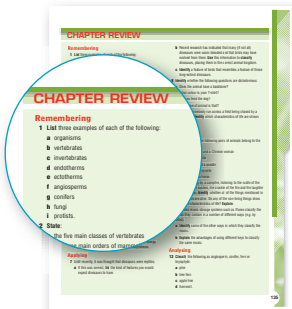

Chapter review questions follow the last unit of each chapter. These questions are structured around Bloom's Taxonomy of Cognitive Processes and cover the chapter learning outcomes in a variety of question styles to allow students the opportunity to consolidate new knowledge and skills.

Other features or icons

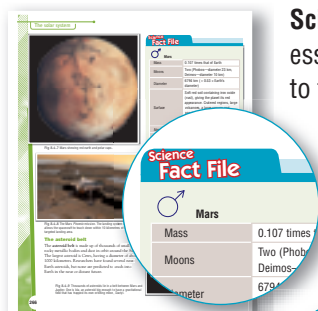

Science Fact File boxes contain essential science facts relevant to the topic.

Science Clip features contain quirky information related to the topic that students will find interesting.

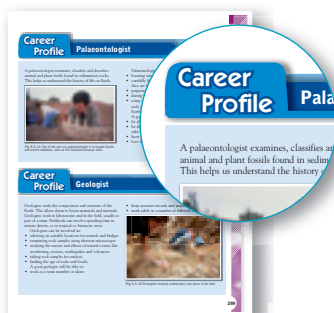
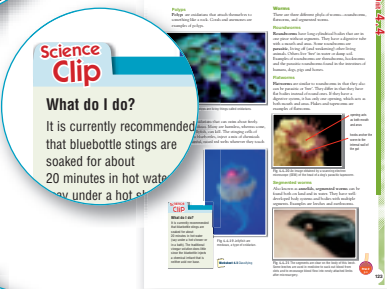

Career Profile boxes appear throughout the book, covering information about specific careers in science.

Case study boxes cover an in-depth exploration of a single case or topic.

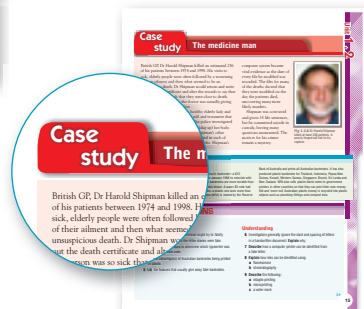

Science Focus spreads appear throughout the book. These are special features on various aspects of science including history, the impact of science on society and the environment

and current research and development. The features allow students to explore science in further detail through a range of student activities.



Literacy and numeracy icons appear throughout to indicate an emphasis on literacy or numeracy. **N** **L**

Go to icons direct students to a unit within the same stage of the NSW curriculum. This unit reference allows students to revisit or extend knowledge. **Go to**

Aboriginal flag icons denote material that is included to cover Indigenous perspectives in science.

Pearson Places icons direct students to the **Science Focus 4 Second Edition Student Lounge** on Pearson Places. The Student Lounge contains animations, video clips, web destinations, drag-and-drop interactives and revision questions.

Sci Q Busters appears after Chapter 9 and provides answers to student questions. Students are able to email questions that come up during class time to the Q Busters team at SciQBusters@pearson.com.au

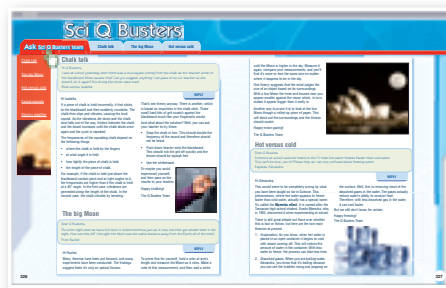

The Science Focus 4 Second Edition package

Don't forget the other **Science Focus 4 Second Edition** components that will help engage and excite students in science:

- Science Focus 4 Second Edition Homework Book**
- Science Focus 4 Second Edition Teacher Edition, with CD**
- Science Focus 4 Second Edition Pearson Reader**
- Science Focus 4 Second Edition LiveText™**

Stage 5 Syllabus Correlation

Science Focus 4

chapter	1	2	3	4	5	6	7	8	9
	Chemical and nuclear reactions	Materials	Genetics	Health and disease	Evolution	Motion	Electricity, electromagnetism and communications technology	Global issues	Individual research project
Outcomes	5.1		▲		▲				
	5.2	•			•				▲
	5.3	▲				▲	▲		
	5.4		▲		▲			▲	
	5.5			▲				•	
	5.6	•					•	•	•
	5.7	•	•						
	5.8			•	•	•			•
	5.9						•		
	5.10		•						
	5.11		•					•	
	5.12		•	•	•		•	•	•
	5.13	•	•	•	•	•	•	•	•
	5.14	•	•	•	•	•	•	•	•
	5.15	•	•	•	•	•	•	•	•
	5.16	•	•	•	•	•	•	•	•
	5.17	•	•	•	•	•	•	•	•
	5.18	•	•	•	•	•	•	•	•
	5.19	•	•	•	•	•	•	•	•
	5.20			•	•	•	•	•	•
	5.21		•	•	•	•	•	•	•
	5.22	•	•	•	•	•	•	•	
	5.23			•	•			•	•
	5.24			•		•			
	5.25				•	•	•	•	•
	5.26	•	•	•	•	•	•		•
	5.27		•					•	

Note: ▲ indicates the key Prescribed Focus Area covered in each chapter.
Chapters may also include information on other Prescribed Focus Areas.

Verbs

Science Focus Second Edition uses the following verbs in the chapter questions under the headings of Bloom's Taxonomy of Cognitive Processes. The verbs in black are the key verbs that have been developed to help provide a common language and consistent meaning in the Higher School Certificate documents. All other verbs listed below feature throughout the book and are provided here for additional support to teachers and students.

Remembering

List	write down phrases only without further explanation
Name	present remembered ideas, facts or experiences
Present	provide information for consideration
Recall	present remembered ideas, facts or experiences
Record	store information and observations for later
Specify	state in detail
State	provide information without further explanation

Understanding

Account	account for: state reasons for, report on. Give an account of: narrate a series of events or transactions
Calculate	ascertain/determine from given facts, figures or information (simply repeating calculations that are set out in the text)
Clarify	make clear or plain
Define	state meaning and identify essential qualities
Describe	provide characteristics and features
Discuss	identify issues and provide points for and/or against
Explain	relate cause and effect; make the relationships between things evident; provide why and/or how
Extract	choose relevant and/or appropriate details
Gather	collect items from different sources
Modify	change in form or amount in some way
Outline	sketch in general terms; indicate the main features of
Predict	suggest what may happen based on available information
Produce	provide
Propose	put forward for consideration or action
Recount	retell a series of events
Summarise	express, concisely, the relevant details

Applying

Apply	use, utilise, employ in a particular situation
Calculate	ascertain/determine from given facts, figures or information
Demonstrate	show by example
Examine	inquire into
Identify	recognise and name
Use	employ for some purpose

Analysing

Analyse	identify components and the relationship between them; draw out and relate implications
Calculate	ascertain/determine from given facts, figures or information (requiring more manipulation than simply applying the maths)
Classify	arrange or include in classes/categories
Compare	show how things are similar or different
Contrast	show how things are different or opposite
Critically (analyse/evaluate)	add a degree or level of accuracy/depth, knowledge and understanding, logic, questioning, reflection and quality to (analyse/evaluate)
Discuss	identify issues and provide points for and/or against
Distinguish	recognise or note/indicate as being distinct or different from; to note differences between
Interpret	draw meaning from
Research	investigate through literature or practical investigation

Evaluating

Appreciate	make a judgement about the value of
Assess	make a judgement of value, quality, outcomes, results or size
Critically (analyse/evaluate)	add a degree or level of accuracy/depth, knowledge and understanding, logic, questioning, reflection and quality to (analyse/evaluate)
Deduce	draw conclusions
Draw	draw conclusions, deduce
Evaluate	make a judgement based on criteria; determine the value of
Extrapolate	infer from what is known
Investigate	plan, inquire into and draw conclusions
Justify	support an argument or conclusion
Propose	put forward (for example a point of view, idea, argument, suggestion) for consideration or action
Recommend	provide reasons in favour
Select	choose one or more items, features, objects
Construct	make; build; put together items or arguments
Design	provide steps for an experiment or procedure
Investigate	plan, inquire into and draw conclusions about
Synthesise	put together various elements to make a whole

Chemical and nuclear reactions

1

Prescribed focus area

Applications and uses of science

Key outcomes

5.3, 5.6.5, 5.7.3

- New substances are formed when atoms rearrange in a chemical reaction.
- Word equations can be written from observations and from written descriptions of what is happening.
- Combustion and corrosion occur when a compound or metal reacts with oxygen.
- Corrosion occurs when a metal reacts with oxygen and water.
- The nuclei of radioactive atoms release particles called alpha particles, beta particles and gamma rays.

- Element symbols and chemical formulae are used as internationally recognised symbols to identify elements and compounds.
- When substances bond they are classified as either ionic or covalent compounds.
- Fission occurs when large nuclei split apart. Fusion occurs when small nuclei fuse together. In both cases, huge amounts of energy are released.
- Radioactivity is the release of particles and energy from the nucleus.

Essentials

Additional

context

Every day, chemical reactions are taking place inside and around you. Chemical reactions digest food and release energy to your cells. They occur when you are cooking at the stove and when you run to answer the phone. They occur in

factories when something is being manufactured. By understanding how these chemical reactions work, scientists are able to control how fast or how slow a reaction takes place. This knowledge makes industrial processes more efficient, conserves the environment and can even save your life in a medical emergency.



Fig 1.1.1 Different kinds of atoms react differently. Here iron reacts with sulfur.

Go to  Science Focus 3 Unit 3.1

**Change**

The substances around you are changing all the time. The ice in a drink melts away to become part of its liquid, a cake is baking in the oven, rising and giving off wonderful smells, and rubbish in the bin is starting to rot and smell bad. Changes are also happening within you—your cells are using oxygen and releasing carbon dioxide and substances are dissolving in your digestive system. Changes can be classified into three broad categories.

- **Physical change:** When a substance undergoes a physical change, no new substances are formed. For example, when glass is broken or an aluminium can is crushed, they undergo a physical change. **Changes of state** such as melting, freezing, boiling and condensing are other examples of physical change. Dissolving a substance in water is also classified as a physical change because no new substance is formed and the original substance can be recovered by simply evaporating the water.

- **Chemical change:** During a chemical change, atoms are rearranged to form new substances. No new atoms are formed in a chemical change and none are destroyed. However, new substances are made and old ones seem to ‘disappear’ as the atoms are arranged differently and combined in different ways. Chemical changes occur via chemical reactions. A **chemical reaction** is occurring whenever you see a permanent colour change, the production of a new solid, liquid or gas, or when energy is produced or absorbed (usually accompanied by a change in temperature). Exploding fireworks are an example of a chemical reaction that produces coloured light, heat and a very loud noise. The ripening of fruit is also a chemical reaction because



Fig 1.1.2 Cooking is a complex mixture of physical and chemical changes. Sugar and salt are dissolved, moisture is evaporated and food is dried out (all physical changes). Cooking then causes the structure of the food to change, possibly even reducing it to carbon (chemical changes). Luckily, no nuclear changes are involved!

of the permanent colour change. The fizzing of a headache tablet in water indicates that gas is being produced and so it too is a chemical reaction.

- **Nuclear change:** A nuclear change occurs when the internal structure of an atom changes. When this happens, new types of atoms and elements are produced. For example, when uranium atoms undergo nuclear change they change into atoms of a completely different element, lead. Nuclear changes occur via nuclear reactions and are usually accompanied by an emission of nuclear radiation.



Chemical change

A chemical change occurs when substances undergo a chemical reaction. A chemical reaction provides a way for atoms to rearrange themselves into new substances. You can tell that a chemical change has occurred by looking for these signs.

- A permanent change in colour—toast turning brown and leaves changing their colour in autumn are signs that a chemical reaction has taken place.
- A gas being given off—sometimes the gas released will be quite visible because of its colour. If the reaction happens in a liquid, then bubbles will form. This is what happens in a can of soft drink or when you burp.
- A new solid (**precipitate**) forms—a precipitate sometimes forms when two soluble substances react together. Being insoluble, the precipitate comes out of the solution, first making it appear cloudy and eventually settling on the bottom. This is what happens when lime and scale forms in pipes and kettles.
- Energy being absorbed or produced—this change will be accompanied by a drop in temperature or the release of heat and light. This is what is happening when natural gas (methane) is ignited in a Bunsen burner or when a sparkler is lit at a party.



Symbols and formulae

Chemical reactions are an important part of your everyday life and the world around you. As a result, chemists have developed shorthand ways of writing about chemicals and their reactions. A set of internationally recognised notations allow them to communicate more quickly and more effectively about what is happening.

Element symbols

Elements are the basic building blocks of matter. Each element contains atoms of one basic type and each element is given its own element symbol. Carbon, for example, is the element that makes up the black material when you burn things, such as wood in an open fire, bread in the toaster or chops on the barbecue. Carbon only contains carbon atoms and is given the symbol C. Another element is copper, the orange-coloured metal that makes up the wiring that carries electricity around your house. It contains only copper atoms and is given the symbol Cu.

There are only 118 basic types of atom and so there can only be 118 different elements: 92 are naturally occurring and the other 26 are not found in nature but have been made in the laboratory.

Chemical formulae

Chemical formulae are used as shorthand notation to represent chemicals which can often have long and incredibly complicated scientific names. Each element, a substance containing atoms of only one type, has its own symbol.

Chemical formulae for molecules

Molecules are small groups of atoms which are tightly bonded together. The chemical formula of a molecule indicates:

- what type of atoms are in each molecule (the element symbols used in the formula)
- how many of each atom there are (the subscripts or small numbers written under each symbol).







For example, a molecule of carbon dioxide has one atom of carbon and two atoms of oxygen. This gives carbon dioxide the chemical formula CO_2 where the number two indicates that there are two oxygen atoms. Scientists do not write C_1O_2 because if the symbol is given without a number, then it is already assumed that there is only one. Similarly, the chemical formula for sugar (glucose) is $\text{C}_6\text{H}_{12}\text{O}_6$ which indicates that there are six carbon atoms, 12 hydrogen atoms and six oxygen atoms in every glucose molecule.

Science Fact File

It's the law!

Element symbols can have either one or two letters: the first must always be written as a capital and the second always in lowercase. This means that the symbol for cobalt is Co and not co or CO (which is shorthand for something completely different, carbon monoxide). An element's symbol may not always correspond to its name in English. This is because the symbols for elements are derived from their Latin names. *Aurum*, for example, is the Latin word for gold which is given the element symbol Au. Likewise, copper (Cu) is *cuprum*.

	Group I	Group II											Group III	Group IV	Group V	Group VI	Group VII	Group VIII	
Period 1	H hydrogen 1																		He helium 2
Period 2	Li lithium 3	Be beryllium 4											B boron 5	C carbon 6	N nitrogen 7	O oxygen 8	F fluorine 9	Ne neon 10	
Period 3	Na sodium 11	Mg magnesium 12											Al aluminium 13	Si silicon 14	P phosphorus 15	S sulfur 16	Cl chlorine 17	Ar argon 18	
Period 4	K potassium 19	Ca calcium 20	Sc scandium 21	Ti titanium 22	V vanadium 23	Cr chromium 24	Mn manganese 25	Fe iron 26	Co cobalt 27	Ni nickel 28	Cu copper 29	Zn zinc 30	Ga gallium 31	Ge germanium 32	As arsenic 33	Se selenium 34	Br bromine 35	Kr krypton 36	
Period 5	Rb rubidium 37	Sr strontium 38	Y yttrium 39	Zr zirconium 40	Nb niobium 41	Mo molybdenum 42	Tc technetium 43	Ru ruthenium 44	Rh rhodium 45	Pd palladium 46	Ag silver 47	Cd cadmium 48	In indium 49	Sn tin 50	Sb antimony 51	Te tellurium 52	I iodine 53	Xe xenon 54	
Period 6	Cs cesium 55	Ba barium 56	La* lanthanum 57	Hf hafnium 72	Ta tantalum 73	W tungsten 74	Re rhenium 75	Os osmium 76	Ir iridium 77	Pt platinum 78	Au gold 79	Hg mercury 80	Tl thallium 81	Pb lead 82	Bi bismuth 83	Po polonium 84	At astatine 85	Rn radon 86	
Period 7	Fr francium 87	Ra radium 88	Ac** actinium 89	Rf rutherfordium 104	Ha hahnium 105	Sg seaborgium 106	Ns nielsbohrium 107	Hs haffium 108	Mt meitnerium 109	Ds darmstadtium 110	Rg roentgenium 111	Uub 112	Uut 113	Uua 114	Uup 115	Uuh 116	Uus 117	Uuo 118	
Lanthanides			Ce cerium 58	Pr praseodymium 59	Nd neodymium 60	Pm promethium 61	Sm samarium 62	Eu europium 63	Gd gadolinium 64	Tb terbium 65	Dy dysprosium 66	Ho holmium 67	Er ersium 68	Tm thulium 69	Yb ytterbium 70	Lu lutetium 71			
Actinides			Th thorium 90	Pa protactinium 91	U uranium 92	Np neptunium 93	Pu plutonium 94	Am americium 95	Cm curium 96	Bk berkelium 97	Cf californium 98	Es einsteinium 99	Fm fermium 100	Md mendelevium 101	No nobelium 102	Lr lawrencium 103			

Legend	 metals	 symbol name atomic number
 liquid at room temperature	 metalloids	
 gas at room temperature	 non-metals	
	 noble gases (non-metals)	

	transition elements	
Ce	lanthanides	Lu
Th	actinides	Lr

Fig 1.1.3 The periodic table lists all 118 known elements.

The formulae for some other molecules are:

- oxygen gas O_2
- hydrogen gas H_2
- ethane C_2H_6
- ethanoic acid (acetic acid/vinegar) CH_3COOH
- hydrogen chloride (hydrochloric acid) HCl
- sulfuric acid H_2SO_4
- nitric acid HNO_3
- water H_2O
- methane CH_4
- ammonia NH_3

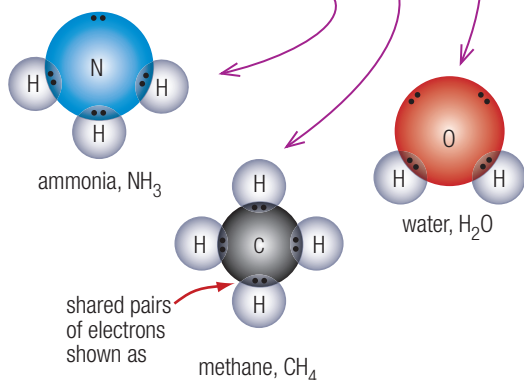

Fig 1.1.4

Science Fact File

Bonding

Atoms rarely exist by themselves in nature but join to other atoms to form the small groupings known as molecules or large ionic or metallic lattices. The type of bonding that takes place between atoms depends on the type of atoms involved, specifically whether the combination is between a metal and a non-metal or between a non-metal and another non-metal or between a metal and another metal.

Go to [Science Focus 4 Unit 2.1](#)

Chemical formulae for lattices

Not all substances form molecules but instead form large crystal lattices. In a lattice, the chemical formula indicates:

- what type of atoms make up the lattice
- the proportion of each.

For example, the chemical formula for common table salt (sodium chloride) is $NaCl$. This formula indicates that there is one chlorine for every sodium in the crystal. The numbers do not give any idea of how many atoms are actually in the crystal (there are billions) but only tell you that they are in the ratio of 1:1.

Science Fact File

Covalent bonding

Covalent bonds only occur between non-metal atoms, such as carbon (C) and oxygen (O), sulfur (S) and hydrogen (H), nitrogen (N) and fluorine (F). Two non-metal atoms will share electrons rather than form ions because most non-metals require extra electrons to become stable. The shared electrons act like glue, holding the two atoms together.

It is possible to build chains or rings of covalently bonded atoms. However, as the chains become longer, the molecules usually become more unstable and, as a result, covalently bonded solids will almost never form large crystal lattices like ionic solids. Instead, covalent substances are made up of a large number of small molecules. The notable exception to this rule is carbon. Carbon has the ability to form large lattices of covalent bonds in diamond and graphite. It is this property that allows carbon to form the huge range of organic molecules and makes life possible.

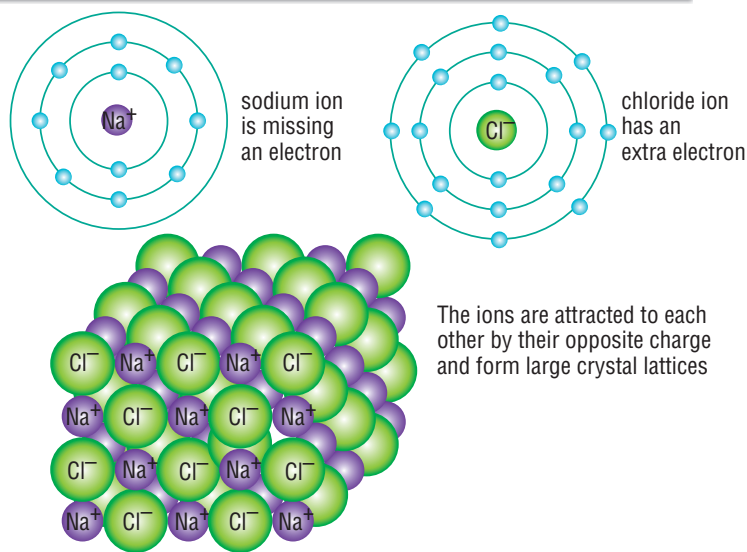

Fig 1.1.5 Common table salt is an example of an ionic solid. The chemical name for table salt is sodium chloride ($NaCl$). It is made up of a crystal lattice of sodium ions (Na^+) and chloride ions (Cl^-).

Similarly the formula for magnesium chloride is $MgCl_2$ which means that in a crystal of magnesium chloride there are two chlorines for every magnesium.

The formulae for some other lattices are:

- sodium chloride (table salt) $NaCl$
- iron oxide (rust) Fe_2O_3
- magnesium chloride $MgCl_2$
- copper(II) phosphate $Cu_3(PO_4)_2$
- lithium carbonate Li_2CO_3
- calcium oxide CaO
- barium oxide BaO

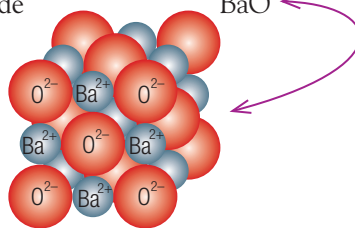

Fig 1.1.6

Science
Fact File

Ionic bonding

Ionic bonding almost always involves metals combined with non-metals. This is because metal atoms easily lose their outer-shell electrons (valence electrons), while most non-metals are more stable if they gain extra electrons to fill their outermost shell. As a result, the metallic atoms readily give up their electrons to non-metal atoms. This results in the formation of a positive metal ion and a negative non-metal ion. Electrostatic attraction between these positive and negative ions keep them together, binding the ions together to form large crystal lattices.

The formula of an ionic compound is not a molecular formula, since ionic compounds form large crystal lattices, not molecules. Instead, the formula shows the ratio of ions in the crystal. For example, the ionic compound magnesium oxide has the formula MgO. This means that in a crystal of MgO, there is one magnesium ion Mg²⁺ for every oxide ion O²⁻. A small crystal may contain a thousand magnesium ions and a thousand oxide ions, while a larger crystal may contain a million magnesium ions and a million oxide ions. Either way, the formula is simply MgO.

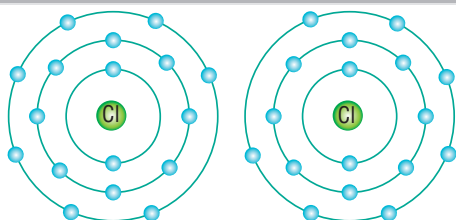

Both chlorine atoms have 7 electrons in their outer shell and both need one more to become stable

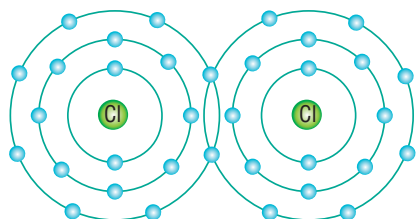

The chlorine atoms form a covalent bond to form a chlorine molecule in which each atom shares one of its electrons with the other

Fig 1.1.7 A chlorine molecule Cl₂ has two chlorine atoms that are covalently bonded. Each chlorine atom has 7 electrons in its outer shell but is most stable with 8 electrons in its outer shell. Therefore, the two atoms pair up so that each chlorine atom shares one electron with the other. In this configuration, both chlorine atoms can have a stable shell of valence electrons.

Chemical equations

Chemists use chemical formulae to communicate what happens during a chemical reaction. They do this by writing a **chemical equation** which takes the general form:



The substances present at the start of a reaction are known as the **reactants**, and the new substances formed are known as the **products**.



A chemical equation can be written as a **word equation** or a **formula equation**.

For example, carbon can be burnt in oxygen to form carbon dioxide. This can be represented as the word equation:



This reaction can also be written as the formula equation:

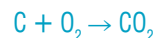

Likewise, the reaction between magnesium and hydrochloric acid may be represented as the word equation:



or as a formula equation:



Bubbles of hydrogen are an indication that a chemical reaction is taking place between magnesium and hydrochloric acid.

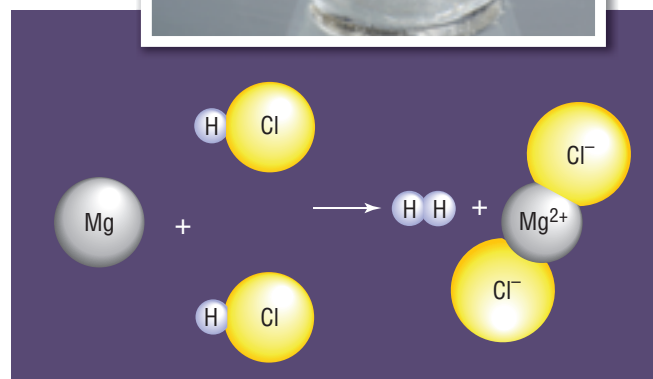
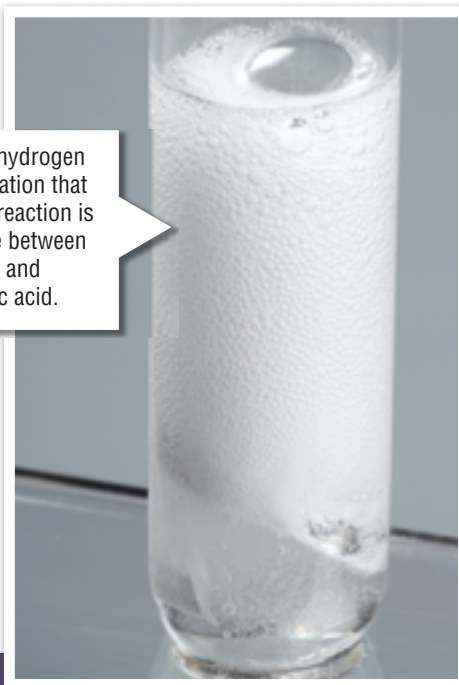

Fig 1.1.8 The number of Mg atoms, H atoms and Cl atoms are the same before and after the reaction of Mg and HCl.

Although this formula equation gives the general idea of what is happening during the chemical reactions, it does not describe exactly what is happening because the equation is unbalanced.

Worksheet 1.1 Writing formulae

Balanced chemical equations

Chemists can communicate even more about what is happening in a chemical reaction by writing **balanced chemical equations**. A balanced chemical equation explains how many reactant molecules are needed to take part in a chemical reaction and how many product molecules are produced. In a balanced equation, there must be an equal number of each type of atom on both sides of the equation. So the balanced equation for magnesium reacting with hydrochloric acid is written as:



This equation shows that one atom of magnesium (Mg) reacts with two molecules of HCl to form the products, MgCl_2 and H_2 . In this equation, the reactants contain a total of one Mg atom, two H atoms and two chlorine atoms. So do the products. Therefore, the equation is balanced.

As another example, consider the reaction between hydrogen gas and oxygen gas to produce water. The word equation and unbalanced formula equation for this reaction are written as:

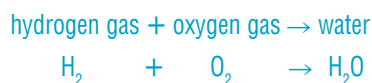

This equation indicates that during the chemical reaction, a hydrogen molecule combines with an oxygen molecule to produce a water molecule. However, this is not the complete picture. There are two atoms of oxygen in an oxygen molecule but only one atom of oxygen in a water molecule. So an oxygen atom is missing!

It is not possible for an atom to simply disappear, so scientists use the balanced chemical equation:

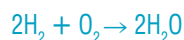

This equation now indicates that two molecules of hydrogen combine with one molecule of oxygen to produce two molecules of water. Now, the reactants have a total of four hydrogen atoms and two oxygen atoms. The two water molecules also contain four hydrogen atoms and two oxygen atoms. Therefore, the equation is balanced.

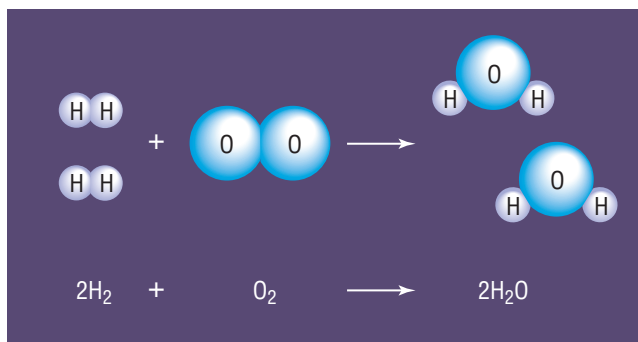

Fig 1.1.9 A balanced equation has the same number and type of atom on each side of the equation.

Science Fact File

Balancing equations

When balancing equations, you must follow a simple set of rules.

- Atoms cannot appear from nowhere nor can they disappear. There must be the same number of each atom of each element on either side of the chemical equation.
- You cannot change the small subscript numbers in a formula. For example, H_2O is water but H_2O_2 is hydrogen peroxide, a type of bleach that would be incredibly dangerous to wash with or drink. Change the subscript and you change the chemicals.
- You can only change the number in front of each chemical formula. For example, if you want to double the number of oxygen atoms in an equation, do not change O_2 into O_4 . O_4 does not exist in that form and you can't just go about creating things that don't exist! Instead, write 2O_2 .
- If you place a number in front of a compound like $\text{Al}_2(\text{CO}_3)_3$, then you have multiplied all the atoms in the formula by that number. For example:

$2\text{Al}_2(\text{CO}_3)_3$ contains:
 $2 \times 2 = 4$ Al atoms
 $2 \times 1 \times 3 = 6$ C atoms
 $2 \times 3 \times 3 = 18$ O atoms

The smaller subscript numbers show how many of each type of atom are present.

H_2O represents

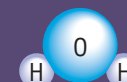

CH_4 represents

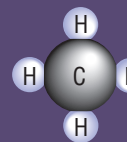

Fig 1.1.10 Subscripts are the small numbers in a formula. They tell you how many atoms are in a molecule. Change them and you change the chemical to a completely different one!

Putting a '2' in front of a formula means two of that chemical

e.g. 2HCl means



Fig 1.1.11 The large numbers in front of a formula tells you how many molecules are being used or made. This is what 2HCl looks like.

Conservation of mass

Atoms cannot simply appear from nowhere in a chemical reaction, nor can they disappear. This fundamental fact is known as the **Law of Conservation of Mass** and is the reason why equations must be balanced. It states that the total mass of the products after a chemical reaction is exactly equal to total mass of the reactants before the chemical reaction. So if you perform a chemical reaction inside a completely closed container, the mass of the container will be exactly the same before and after the reaction.



The state of reactants and products

When describing chemical reactions it is also important to communicate the state of the reactants and products, in other words, whether they are solid, liquid, gas or in an aqueous solution (dissolved in water).

As an example, consider the reaction of calcium carbonate with hydrochloric acid:



Each substance in the reaction is in a different state: calcium carbonate is solid, hydrochloric acid is an aqueous solution, carbon dioxide is a gas, water is a liquid, calcium chloride is an aqueous solution, remaining dissolved in water.

To communicate all of this information, the word equation could be written as:

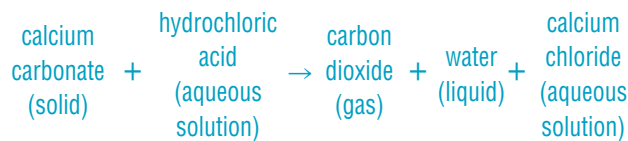

To avoid writing such long-winded word equations, subscripts are added to each substance in the chemical equation. The subscripts used are:

- (s) solid
- (l) liquid
- (g) gas
- (aq) aqueous solution.

The above chemical equation can then be rewritten as:



Worksheet 1.2 Chemical equations

Worksheet 1.3 Chemical reactions



Science Clip

Lights, action!

Calcium oxide (quicklime) produces an intense white light when it is burnt and so was used as an early spotlight in theatres. The performers on stage were 'in the limelight', a term that is still used for a person who is the centre of attention.

Controlling reaction rates

Some chemical reactions occur rapidly, like when a bullet is fired or petrol ignites in a car engine. Other reactions occur very slowly, such as rusting of metal or grapes fermenting to make wine. However, it is often important to speed up a reaction or slow down a reaction. Changing the temperature is one way of controlling the rate of reaction. Other ways include changing the concentration of the reactants or products, changing the surface area of reactants, or adding chemicals called catalysts to assist the reaction.

Temperature

Changing the temperature is one of the most common and effective ways of controlling the rate of reactions. Increasing the temperature of the reactant molecules gives them more energy. This means the molecules bump into each other more often and with greater force, making a reaction between the molecules more likely. As a result, the reaction becomes faster. Some reactions will not proceed until the molecules are given enough energy to allow them to react.

Science Clip

Soggy middles

When you bake a cake, you are using the heat of the oven to cause a chemical reaction between all the ingredients and you set the temperature to control the rate of reaction. If you set the temperature too high, then the outside of the cake will burn before the middle has a chance to cook. If you set the temperature too low, the reaction will take too long or perhaps will not occur at all.



Fig 1.1.12 The oven temperature was too high when this cake was baked.

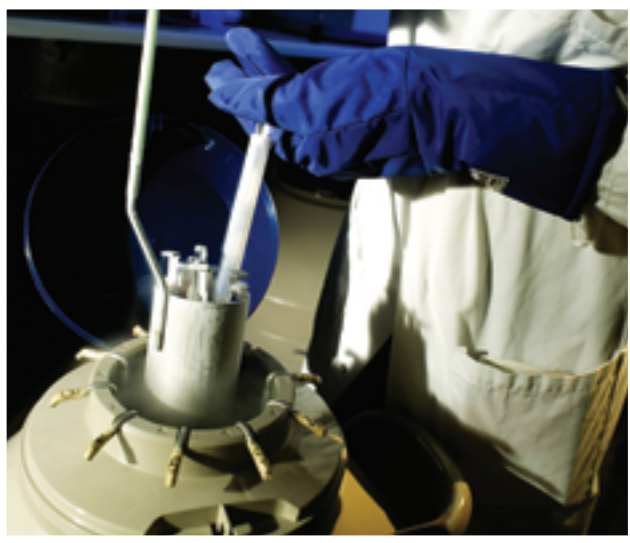

Fig 1.1.13 Increased temperatures are used to speed up reactions in industry such as the extraction of iron in a blast furnace or the firing of roof tiles in huge kilns. However, reducing the temperature is also used to slow reactions down such as to slow the ripening of fruit on the way to market or to preserve human egg cells for in-vitro fertilisation.

Concentration

Concentration measures how much of a particular chemical is in a substance. **Concentrated** means that much chemical is present while **dilute** means little is present.

The concentration of reactants or products also determines the rate of reaction. To make a reaction go faster, you can increase the concentration of reactants or decrease the concentration of products by removing the products as they are being formed. When there is a large concentration of reactant molecules, then they are more likely to collide with one another so the products are formed more quickly. Removing the products also helps to drive the reaction forwards.

There are many examples of how you might change the concentration of reactants or products to speed up or slow down chemical reactions in your everyday life.



Fig 1.1.14 Concentrated solutions contain more of the chemical than a dilute solution. If coloured, a concentrated solution will be brighter or darker than a dilute solution.

A critical reaction for providing energy to your cells is respiration, which can be written using a word equation or a balanced equation:



When you are sprinting, you start breathing in faster and deeper. This increases the concentration of oxygen in your blood to help speed up the process of respiration and produce energy for your cells. By breathing out you are helping to remove the carbon dioxide from your blood, also speeding up respiration.



Science Clip

At the peak of fitness

At high altitudes, where there is less oxygen in the air, people naturally develop more red blood cells to allow them to increase the concentration of oxygen stored in their blood. Elite athletes sometimes take advantage of this by training for several weeks at high altitudes just before a big competition. When they return to sea level, their blood has a super concentration of oxygen to provide their cells with extra energy and endurance.

Fig 1.1.15 This sprinter naturally increases the rate of respiration in her cells by breathing deeply to increase the concentration of oxygen in her blood.

Changing surface area

Changing the surface area of the reactants is very similar to changing the concentration. The more surface area the reactant has, the more molecules there are available to react which makes the reaction faster. The surface area of a reactant can be increased by cutting it into small pieces or grinding it into a powder.

This technique is used in medicine capsules. The capsules are loaded with a fine powder so that when the capsule breaks apart in your stomach, the medicine can be digested and absorbed by the body as quickly as possible.

Catalysts

Another common method for speeding up reactions is to introduce a **catalyst**. Catalysts help the reactant molecules to form the products, but are not changed or used up in the reaction. Even once all the reactants have reacted, the catalyst is still there. Catalysts usually provide a different pathway for the reaction to occur that requires less energy. So, for example, if two reactant molecules must collide with a lot of energy before they can react, then the reaction rate is likely to be slow. However, if the reactant molecules first react with the catalyst and then react with each other, they need less energy to react and so the reaction can proceed more quickly.

Catalysts can also be used to bring several molecules together at one time so that they can react. For example, if a reaction requires that three different molecules must collide simultaneously in order to react, then a reaction is very unlikely. However, if all three molecules stick to the catalyst, then they are much more likely to be at the same place at the same time.

In a car's catalytic converter, the element rhodium helps harmful exhaust fumes react with oxygen to produce less harmful products. Rhodium attracts the harmful gases and oxygen so more of each gas comes together and reacts. The rhodium does not actually react with either gas; it just speeds up the reaction by getting more molecules to come together.

Enzymes

Special types of catalysts called **enzymes** are found in our bodies. Digestive enzymes help break down large molecules such as starch into smaller molecules such as glucose. Think of these enzymes as a pair of scissors and the starch molecule as a string of beads being cut by the enzyme into small beads (the glucose). This allows the starch to be more easily digested and ultimately to be used by body cells. Like all catalysts, digestive enzymes do not combine with other atoms or molecules; they simply help the chemical reactions to occur more quickly.

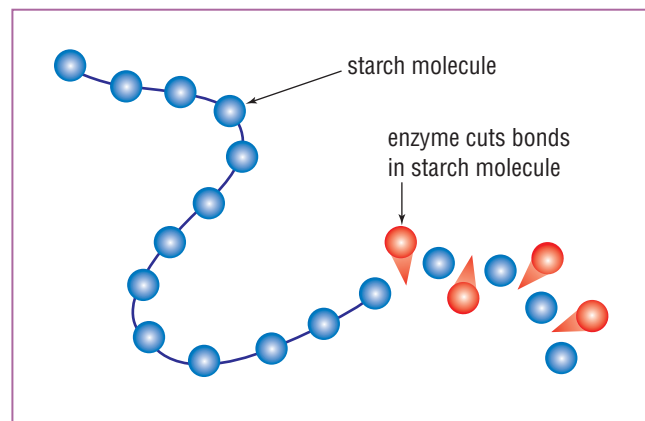

Fig 1.1.16 Enzymes are biological catalysts that break up molecules making reactions proceed faster. Here an enzyme is breaking up a starch molecule.



Science Clip

Hardening fillings

Dentists use a special paste to fill holes in teeth. The paste is then hardened quickly by using ultraviolet (UV) light as a catalyst.



1.1 QUESTIONS

Remembering

- 1 **Name** the following elements and compounds.
- CO_2
 - H_2O
 - NaCl
 - Li_2CO_3
 - N_2
 - CaO
 - Ar
- 2 **List** the subscript symbols used to show the state of matter of substances in chemical equations.
- 3 **Recall** reaction rates by giving an example of:
- a fast reaction
 - a slow reaction
- 4 **List** four ways to obtain a faster reaction rate.

Understanding

- 5 **Define** the terms:
- reactants
 - products
- 6 **Explain** why NaCl is not a molecular formula, but CO_2 is.
- 7 **Explain** why it is necessary to balance equations.
- 8 **Explain** the difference between $\text{NaCl}_{(s)}$ and $\text{NaCl}_{(aq)}$.
- 9 **Calculate** how many Fe, S and O atoms are represented by the formula $6\text{Fe}_2(\text{S}_2\text{O}_3)_3$. **N**

Applying

- 10 Calcium forms the ion Ca^{2+} and chlorine forms the chloride ion, Cl^- . **Identify** the correct formula for calcium chloride.
- CaCl
 - Ca_2Cl
 - CaCl_2
 - Ca_2Cl
- 11 **Identify** whether ionic or covalent bonding would occur in a compound made from:
- a metal and another metal
 - a metal and a non-metal
 - hydrogen and oxygen
 - sodium and fluorine
- 12 **Identify** which elements are not already balanced in the following chemical equations.
- $\text{KClO}_{3(s)} \rightarrow \text{KCl}_{(s)} + \text{O}_{2(g)}$
 - $\text{CH}_{4(g)} + \text{O}_{2(g)} \rightarrow \text{CO}_{2(g)} + \text{H}_2\text{O}_{(l)}$
 - $\text{BaO}_{(s)} + \text{HNO}_{3(aq)} \rightarrow \text{Ba}(\text{NO}_3)_{2(aq)} + \text{H}_2\text{O}_{(l)}$
 - $\text{Pb}_3\text{O}_{4(s)} \rightarrow \text{PbO}_{(s)} + \text{O}_{2(g)}$
 - $\text{C}_6\text{H}_{12}\text{O}_6(s) + \text{O}_{2(g)} \rightarrow \text{CO}_{2(g)} + \text{H}_2\text{O}_{(l)}$
 - $\text{Al}_{(s)} + \text{O}_{2(g)} \rightarrow \text{Al}_2\text{O}_{3(s)}$

Analysing

- 13 **Analyse** the following equations to determine which one *is* correctly balanced.
- $\text{HNO}_3 + \text{MgO} \rightarrow \text{Mg}(\text{NO}_3)_2 + \text{H}_2\text{O}$
 - $2\text{HNO}_3 + \text{MgO} \rightarrow \text{Mg}(\text{NO}_3)_2 + \text{H}_2\text{O}$
 - $2\text{HNO}_3 + 2\text{MgO} \rightarrow 2\text{Mg}(\text{NO}_3)_2 + \text{H}_2\text{O}$
 - $2\text{HNO}_3 + 3\text{MgO} \rightarrow \text{Mg}(\text{NO}_3)_2 + \text{H}_2\text{O}$
- 14 **Analyse** the following equations to determine which equation is *not* balanced.
- $\text{C}_3\text{H}_{12} + 8\text{O}_2 \rightarrow \text{CO}_2 + 6\text{H}_2\text{O}$
 - $\text{Mg} + 2\text{HCl} \rightarrow \text{MgCl}_2 + \text{H}_2$
 - $2\text{Zn} + \text{O}_2 \rightarrow 2\text{ZnO}$
 - $4\text{Al} + 3\text{O}_2 \rightarrow 2\text{Al}_2\text{O}_3$
- 15 **Analyse** the following equations to determine the missing numbers that would balance the equations.
- $\text{P}_4 + 5\text{O}_2 \rightarrow \square\text{P}_2\text{O}_5$
 - $\square\text{KClO}_3 \rightarrow 2\text{KCl} + 3\text{O}_2$
 - $\text{CaCO}_3 + \square\text{HCl} \rightarrow \text{CO}_2 + \text{H}_2\text{O} + \text{CaCl}_2$
 - $2\text{Pb}_3\text{O}_4 \rightarrow \square\text{PbO} + \text{O}_2$ **N**
- 16 **i Calculate** how many atoms of each element are on both sides of the following chemical equations. **N**
- Use this information to balance each equation.
 - Use subscripts to show the states of each substance in each equation.
- $\text{H}_2 + \text{O}_2 \rightarrow \text{H}_2\text{O}$
 - $\text{Na} + \text{Cl}_2 \rightarrow \text{NaCl}$
 - $\text{CaCO}_3 \rightarrow \text{CaO} + \text{O}_2$
 - $\text{CH}_4 + \text{O}_2 \rightarrow \text{CO}_2 + \text{H}_2\text{O}$

Evaluating

17 Deduce the word equation for the following reactions.

- Dilute hydrochloric acid reacts with grains of sodium hydroxide (NaOH). Water and sodium chloride are the products.
- Ammonia (NH₃) gas is produced when nitrogen gas is added to hydrogen gas.
- Carbon monoxide gas combines with oxygen to form carbon dioxide gas.
- Solid iron combines with chlorine gas to produce solid iron(III) chloride (FeCl₃).
- Dilute sodium hydroxide (NaOH) solution is added to dilute sulfuric acid. Sodium sulfate (Na₂SO₄) and water are produced.
- Hydrochloric acid reacts with calcium metal. A solution of calcium chloride (CaCl₂) is produced, with bubbles of hydrogen rising through it.

18 Jessica heated some bright blue copper(II) nitrate (Cu(NO₃)₂) crystals in a test tube. She noticed brown nitrogen dioxide (NO₂) gas being produced. A glowing splint held at the top of the test tube re-lit, proving that oxygen gas was also produced. A fine black solid, copper(II) oxide (CuO), was left in the test tube.

- In this reaction, **state** the reactants and the products.
- Deduce** the word equation for this reaction.
- Deduce** the balanced chemical equation, including states.

19 Solid sodium reacts with oxygen to produce solid sodium oxide (Na₂O). The following experimental data were obtained for the reaction between sodium and oxygen, producing sodium oxide.

Mass of sodium reacting (grams)	Mass of oxygen reacting (grams)	Mass of sodium oxide produced (grams)
2.00	0.70	2.70
3.00	1.04	4.04
4.00	1.39	5.39

- Deduce** a word equation for this reaction.
- Deduce** an unbalanced chemical equation for the reaction, then balance it.
- Modify** the equation to include the states of the reactants and products.
- Explain** what this experiment says about the mass of products relative to the mass of the reactants. **N**

1.1 INVESTIGATING

Investigate your available resources (for example, textbooks, encyclopaedias, internet) to complete the following tasks.

- Research the differences between metallic, covalent and ionic bonding.
- Find links to websites that will either balance equations for you or give you interactive practice at balancing.
- Describe what is meant by 'green chemistry'.
 - Outline some examples of what is being done in the study of green chemistry.
 - Present your information as a poster to convince the general public that green chemistry is important for society and the environment. **L**

4 Connect to the CSIRO double helix website and locate the 'Cool Experiments' page.

- Identify an experiment that involves a chemical reaction and can safely be done at home.
- Perform the experiment and present a scientific report on your findings.

e-xploring

To practise balancing chemical equations, a list of web destinations can be found on **Science Focus 4 Second Edition Student Lounge**.



1.1 PRACTICAL ACTIVITIES

1 Studying a reaction

Aim

To make quantitative observations of the reaction of magnesium metal and an acid

Equipment

- magnesium strips
- 1 M sulfuric acid
- large beaker
- small filter funnel
- 100 mL measuring cylinder
- cling wrap
- gloves
- lab coat
- safety glasses

Method

- 1 Cut a 4 cm long strip of magnesium. Place it under the filter funnel in the beaker.
- 2 Fill the beaker with water until it covers the filter funnel.
- 3 Fill the measuring cylinder with acid and cover it in cling wrap.
- 4 Carefully invert the measuring cylinder on top of the filter funnel. Let the neck of the filter funnel pierce the cling wrap.
- 5 After the bubbling seems to have stopped, measure the volume of gas collected in the measuring cylinder.

Questions

- 1 **Construct** a word equation and the balanced formula equation for this reaction. The products are hydrogen H_2 and magnesium chloride $MgCl_2$.
- 2 **Calculate** the volume of hydrogen gas that you would expect to have been produced if you had instead used:
 - a an 8 cm strip of magnesium
 - a 1 cm strip of magnesium **N**

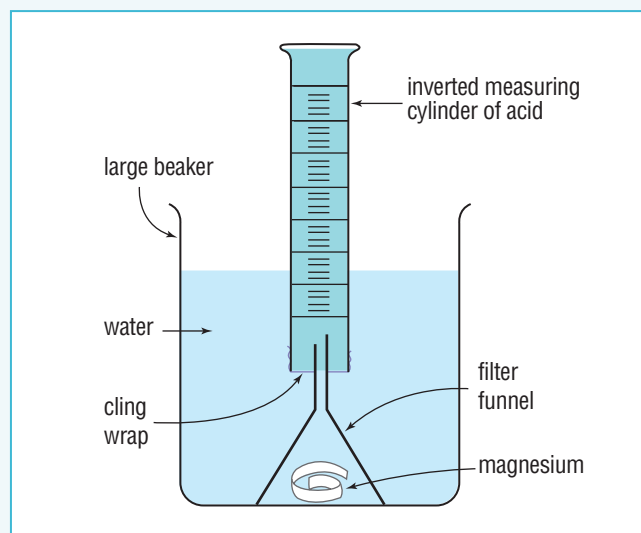

Fig 1.1.17

2 Conservation of mass

Aim

To investigate conservation of mass in a chemical reaction

Equipment

- solid calcium carbonate
- 0.5 M hydrochloric acid
- 200 mL conical flask
- balloon
- spatula
- 100 mL measuring cylinder
- lab coat
- safety glasses
- access to an electronic balance

Method

- 1 Measure out approximately 0.2 g of calcium carbonate in the conical flask.
- 2 Measure out 30 mL of hydrochloric acid into the measuring cylinder.
- 3 Place the conical flask, measuring cylinder and balloon on the balance and record their total weight.
- 4 Pour the acid into the conical flask and quickly place the balloon on top.
- 5 When the reaction is complete, weigh the flask (with balloon attached) and empty measuring cylinder again.

>>

Questions

- Construct** a word equation and balanced formula equation for this reaction.
- Assess** whether your results agree with the Law of Conservation of Mass.
- If your results do not agree with the Law, **propose** reasons why.

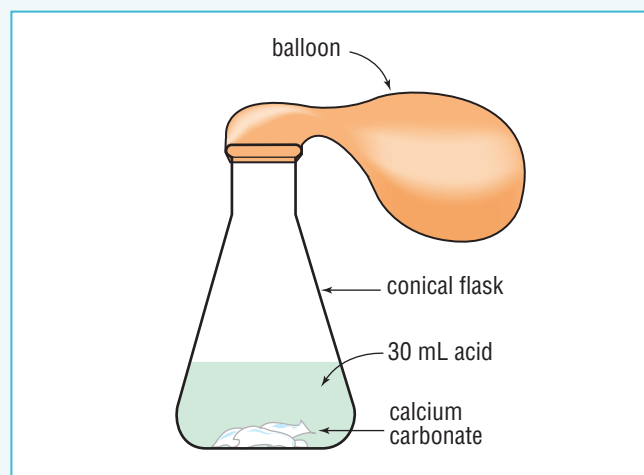

Fig 1.1.18

3 Rates of reactions 1

Aim

To investigate the variables that affect reaction rates

Equipment

- lab coat
- safety glasses
- gloves
- magnesium strips
- ice
- 1 M HCl
- hydrogen peroxide solution
- solid manganese dioxide
- stopwatch
- spatula
- 4 test tubes
- test-tube rack
- 10 mL measuring cylinder
- two 100 mL beakers

Method

- Add a 2 cm strip of magnesium to a test tube.
- Add 5 mL of acid and time how long it takes for the reaction to finish. The reaction is:



- Place 5 mL of acid in the second test tube and sit it in a beaker of ice water.
- Once again, add a 2 cm strip of magnesium and time how long it takes for the reaction to finish.
- Add 2 mL of acid and 3 mL of water to a third test tube.

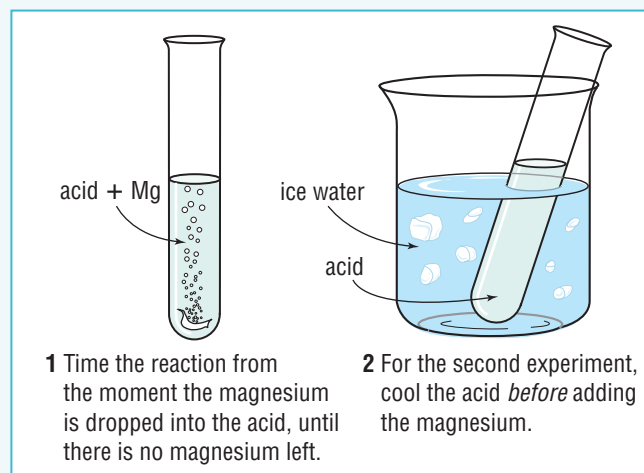

- Time the reaction from the moment the magnesium is dropped into the acid, until there is no magnesium left.
- For the second experiment, cool the acid *before* adding the magnesium.

Fig 1.1.19

- Add a 2 cm strip of magnesium and time how long it takes for the reaction to finish.
- Add 5 mL of hydrogen peroxide solution to each of two beakers. Hydrogen peroxide gradually breaks down according to the equation:



- To one beaker, add a very small amount of manganese dioxide.
- Compare the two beakers and record your observations.

Questions

- Identify** factors that made the reactions proceed faster or slower.
- Predict** the effect of heating the reactions.
- Identify** the role of the manganese dioxide in the hydrogen peroxide reaction.

4 Rates of reactions 2

Aim

To investigate how the surface area affects reaction rate

Equipment

- lab coat
- safety glasses
- gloves
- marble chips (large and small)
- powdered calcium carbonate
- dilute hydrochloric acid
- stopwatch
- spatula
- 4 test tubes
- test-tube rack
- 10 mL measuring cylinder
- electronic balance

Method

- 1 Using the equipment listed, design your own experiment to test the effect of surface area on the rate of reaction.
- 2 Construct a graph to display your results. **N**



Questions

- 1 Use your results to **deduce** how surface area affects the rate of reaction.
- 2 **Propose** how your experiment could be improved.

5 Reaction rate—effect of catalysts and enzymes

Aim

To investigate the effects of catalyst and enzymes on reaction rate

Equipment

- 4 test tubes
- test-tube rack
- fresh hydrogen peroxide solution
- manganese(IV) dioxide
- small piece of fresh liver
- small piece of apple or potato
- wax taper
- safety glasses

Method

- 1 Place a small piece of liver in a test tube.
- 2 Place some manganese dioxide in another test tube.
- 3 Place a small piece of apple or potato in another test tube.
- 4 One-quarter fill another test tube with hydrogen peroxide only. Hydrogen peroxide slowly decomposes into water and bubbles of oxygen. Can you see any bubbles of oxygen forming?
- 5 Place the lighted wax taper into the tube and observe what happens to the flame.
- 6 Add the same amount of hydrogen peroxide to the other test tubes and observe carefully, comparing rates of bubble formation in all three test tubes.

Questions

- 1 Use your observations to **assess** which test tube produced oxygen most rapidly.
- 2 Use your observations to determine whether liver and manganese dioxide were left in the test tubes or consumed by the reaction. **Justify** your answer.
- 3 **Compare** the effect of the apple or potato with that of the manganese dioxide.
- 4 **Predict** whether cooked liver would produce the same results.

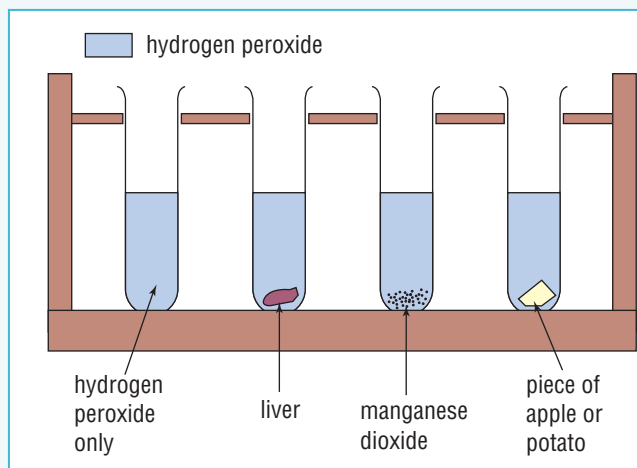

Fig 1.1.20

context

While some chemical reactions are very useful, others can be very destructive and scientists must find ways to prevent them. Rusting is an example of a slow

but destructive chemical reaction that costs the world hundreds of billions of dollars every year by destroying buildings, bridges, cars and ships. Through understanding how things rust, scientists have developed ways to stop it from happening which is helping to reduce this cost.



Fig 1.2.1 Combustion is one form of an oxidation reaction. Ongoing combustion depends on a continuous supply of fuel and oxygen. Take away its oxygen and the reaction soon stops.

Oxidation reactions

Oxygen plays an important role in many chemical reactions. When an element or compound combines with oxygen, it undergoes an **oxidation** reaction. Two classes of oxidation reactions are:

- combustion reactions
- corrosion reactions.

Combustion

Some oxidation reactions are very fast and even explosive, such as the burning of fossil fuels or the reaction of hydrogen gas with oxygen gas. These reactions are known as **combustion** reactions. For example, when magnesium ribbon (Mg) is ignited in air it produces magnesium oxide (MgO) as well as a lot of heat and light:

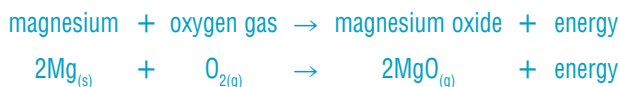

Fig 1.2.2 The explosion of gun powder is an example of a fast oxidation reaction.

Combustion of hydrocarbons

Hydrocarbons are molecules that are made up entirely of a long chain of carbon atoms with hydrogen atoms attached to each carbon atom. Hydrocarbons are exceptionally good fuels, making up most fossil fuels such as natural gas, coal and petrol. This is because the carbon atoms in hydrocarbon chains are held together by very strong chemical bonds of a type known as covalent bonds. A lot of energy is released when covalent bonds are broken during a chemical reaction.

Go to Science Focus 3 Unit 3.2

Complete combustion

When hydrocarbons burn in lots of oxygen, carbon dioxide and water are produced. This is called **complete combustion**. These reactions also produce heat energy which may be harnessed, for example, in coal-fired power stations to produce electricity.

During complete combustion:

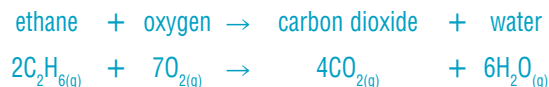



Fig 1.2.3 This gas explosion shows how fast a combustion reaction can be. Combustion reactions like this are a type of oxidation reaction.

Incomplete combustion

Sometimes, if the supply of oxygen is limited, **incomplete combustion** may occur. This is usually characterised by a black, smoky flame.

During incomplete combustion, two reactions tend to occur simultaneously:

Reaction 1

ethane + oxygen → carbon monoxide + water



Reaction 2

ethane + oxygen → carbon + water



Incomplete combustion produces less heat energy than complete combustion and can also produce a deadly pollutant—carbon monoxide gas.



Fig 1.2.4 Incomplete combustion in car engines produces carbon, carbon monoxide and other chemicals that contribute to photochemical smog and air pollution.

Corrosion

Reactions with oxygen that are slower and non-explosive are not referred to as combustion reactions. However, when a metal reacts with oxygen it forms a **metal oxide** and the process may be referred to as **corrosion**. This is because the metal oxide ‘eats away’ or corrodes the metallic element. The most common (and costly) example of this is rusting of iron. Iron (Fe) combines with oxygen gas (O_2) in the air to form iron(III) oxide (Fe_2O_3), which can be distinguished by its orange-red colour. Iron(III) oxide is also known as rust. The reaction is:

iron + oxygen → iron(III) oxide



Iron(III) oxide is flaky and easy to dislodge, allowing the rusting process to continue into the next layer. As a result, the oxidation reaction can over the years ‘eat through’ an entire block of solid iron. Salt and heat speed up the rate at which iron rusts.



Fig 1.2.5 Rusting is a slow reaction but one that eventually destroys unprotected iron and steel in bridges, buildings, cars, machinery, and in this case, ships. Rusting is an example of an oxidation reaction.

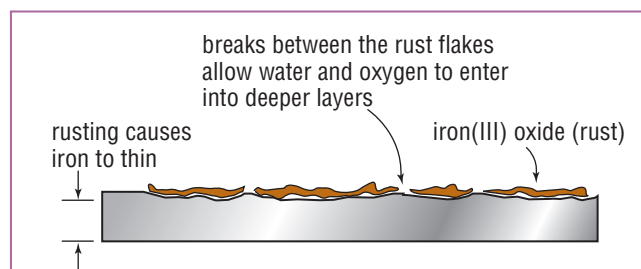
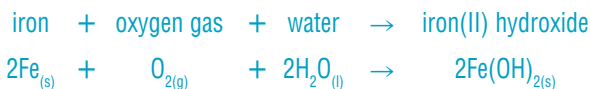

Fig 1.2.6 Rust is flaky and allows water to reach deeper and deeper causing the rest of the iron to rust away too.

Corrosion and oxidation

Although the chemical equation for the oxidation of iron may appear simple, it actually summarises a complex series of reactions. Firstly, the iron metal must react with oxygen and water to produce iron(II) hydroxide:



The iron(II) hydroxide then reacts with oxygen to form iron(III) oxide and water:

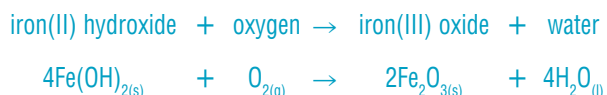

As a result, both oxygen and water must be present as either liquid or vapour for rusting to take place. The rusting process can also be accelerated by salts or heat.



Corrosion protection

Stainless steel is an **alloy** that resists rusting. It is used for surgical apparatus, body piercings and equipment in conditions of high heat and salt, such as in kitchens and on boats. Other types of steel can be protected by coatings, such as oil, paint or plastic that stop air and water from reaching the surface. A scratch or crack in the coating, however, allows rusting to start again.

Sacrificial protection

Another method is to coat the surface or attach another more reactive metal. **Galvanised** iron is iron dipped in molten zinc. Zinc is more reactive than iron and will react instead of it. This is called **sacrificial protection**. Scratches and chips will not rust, as long as some zinc is close by. Nails and roofing materials are commonly made from galvanised iron. Reactive magnesium blocks



Fig 1.2.7 Stainless steel is an alloy that resists rusting, even in the hot and salty conditions of a kitchen or on a boat.

are often bolted onto steel structures such as piers and deepwater gas rigs and oil rigs at sea. The magnesium sacrifices itself to protect the structure.

The activity series

When two metals are placed in contact with one another, the more reactive metal will provide sacrificial protection for the less reactive metal. The reactivity of a metal is determined by how easily it loses its electrons. A metal that loses its electrons easily is highly reactive while metals that tend to hold on to their electrons are

Science Clip

The cost of corrosion

The CSIRO estimates that the annual cost of corrosion in Australia is approximately \$13 billion dollars.

Method of protection	Uses	Advantages	Disadvantages
Painting	Car bodies, cast iron lacework	Cheap, easy, attractive	Chips and scratches easily
Layer of grease or oil	Tools, machine parts	Cheap, easy, lubricates parts	Messy and needs to be reapplied regularly
Plastic coating	Dish racks, outdoor furniture	Cheap, attractive	Cracks allow water to enter; plastic deteriorates with age
Tin plating	Food cans	Does not react with food, non-toxic, less reactive than iron/steel	Needs electrolysis to plate steel; expensive, scratches and will rust
Chromium plating	Car parts	Attractive	Needs electrolysis to plate steel; expensive, scratches and will rust

less reactive. The relative reactivity of metals is described by the **activity series**.

Metals higher on the activity series:

- are more likely to react with other chemicals
- form compounds that are more stable.

As a result, metals higher on the activity series will provide sacrificial protection for those below.

From the activity series you can expect potassium, sodium, calcium, magnesium, aluminium and zinc to protect iron from corrosion. However, potassium, sodium and calcium are never used because they are so reactive to the point of being explosive.

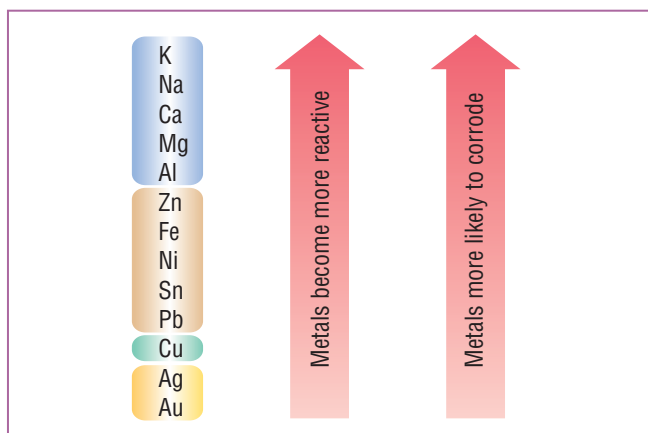

Fig 1.2.8 The activity series shows which metals are more likely to corrode and which will be resistant. The activity series can be used to predict which metals will sacrificially protect other metals. Zinc, for example, will protect iron by sacrificing itself.

Go to Science Focus 4 Unit 2.2

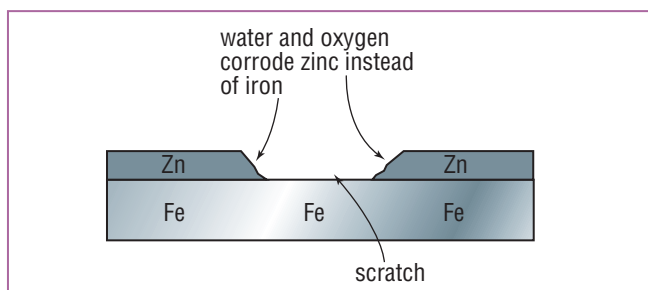

Fig 1.2.9 In galvanised iron, zinc sacrifices itself to protect the iron it plates.

Tin is less reactive than iron and so will protect steel (which is mostly iron) that is coated in it. However, if the tin is scratched, the iron will rust once more. The tin will not sacrificially protect the iron. This is why tin cans (which are really steel cans coated in tin) will corrode rapidly if the tin coating is scratched or broken. In this case, the iron is providing sacrificial protection for the tin.

Aluminium: reactive but it doesn't corrode

Aluminium is a very reactive metal and the surface reacts almost immediately with the air to form a fine layer of dull grey **aluminium oxide**, Al_2O_3 .



Unlike rust, this layer of aluminium oxide does not flake. Instead, it acts like a tightly bound layer of paint. Aluminium needs no further protective treatment.

Worksheet 1.5 Metal experiments

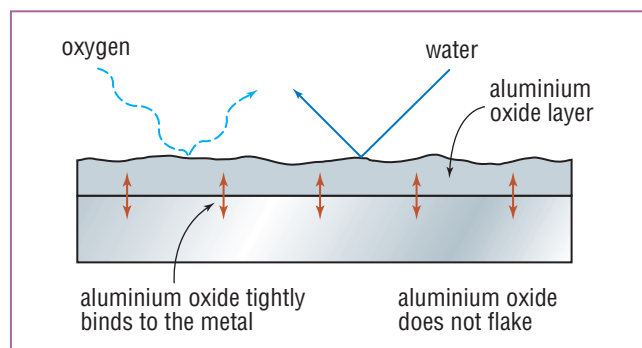

Fig 1.2.10 Aluminium oxide acts like the perfect paint layer—hard to scratch and non-flaky.



Science Clip

Colour it green

Anodising is one of the more environmentally-friendly, metal-finishing processes producing very few harmful by-products. The most common anodising by-products are recycled for the manufacturing of baking powder, cosmetics, newsprint and fertiliser or used by industrial wastewater treatment systems.

Fig 1.2.11 Anodising is a technique where the layer of aluminium oxide is deliberately built up using electrolysis. Colours may be added as the layers are deposited. Saucepans and window frames are often made from anodised aluminium.

1.2 QUESTIONS

Remembering

- List two types of oxidation reactions.
- Recall the combustion of hydrocarbons by writing:
 - the chemical equation for the complete combustion of ethane
 - two chemical equations that describe the incomplete combustion of ethane
- Name the following chemicals:
 - O_2
 - MgO
 - C_2H_6
 - Fe_2O_3
 - $Fe(OH)_2$
- List the three substances required for iron to rust.
- State two things that speed up the rate at which iron rusts.
- Recall the chemical equations listed below by writing the balanced chemical equations for:
 - iron (Fe) converting to iron(II) hydroxide
 - iron(II) hydroxide converting to iron(III) oxide
 - aluminium converting to aluminium oxide
- List three ways in which iron and steel can be protected from corrosion.
- Name a metal that:
 - would be likely to corrode explosively when exposed to water
 - would be unlikely to corrode at all
 - that would sacrificially protect iron
 - that would be protected from corrosion by a layer of iron
- Name the corrosion-resistant coating formed on aluminium.

Understanding

- Outline what is meant by the terms:
 - sacrificial protection
 - galvanising
 - anodising

- Explain why steel window frames would be a bad choice near the sea.
- Explain why galvanising gives better protection than painting an iron surface.
- Explain how rusting continues into deeper and deeper layers of iron.
- A shiny sheet of aluminium quickly dulls to a grey surface. Explain how this actually protects the aluminium.
- Zinc doesn't rust but it does corrode.* Explain what this statement means.

Applying

- Identify the chemical that all oxidation reactions require.
- A Bunsen burner can produce a yellow flame and a blue flame.
 - Identify which flame shows complete combustion and which shows incomplete combustion.
 - Describe the evidence you used to answer part a.
 - Identify which flame required an open airhole and which required a closed airhole.
- Methane (CH_4) gas burns in oxygen gas (O_2) to form carbon dioxide and water vapour. Use this information to write:
 - a word equation
 - an unbalanced formula equation
 - a balanced chemical equation
- Combustion happens within the cells of the body in a specialised process known as respiration. In it, glucose ($C_6H_{12}O_6$) reacts with oxygen gas (O_2) to form carbon dioxide (CO_2), water vapour and energy. Use this information to write:
 - a word equation for respiration
 - an unbalanced formula equation
 - a balanced chemical equation
- Identify instances around your home or school where iron or steel is used.
 - Identify the ways in which the iron/steel is protected from corrosion.
- Three sheets of iron are each coated in a different metal: copper, magnesium and tin. Use the activity series in Figure 1.2.8 to predict what will happen to each sheet when the coating is scratched.

Analysing

22 Wood in an open fire undergoes a combustion reaction.

Discuss what you could do to:

- a** increase the rate of this combustion reaction
- b** slow it down
- c** stop it completely

Evaluating

23 You need to protect a zinc structure from corrosion. **Propose** which metals you could bolt onto the zinc to protect it.

24 a Of the metals listed in the activity series in Figure 1.2.8, name the metal that you think is the most valuable on Earth. **Justify** your answer.

b Many would say that iron is the most valuable metal on Earth. **Explain** why they might think that.

Creating

25 Construct balanced chemical equations for the following oxidation reactions:

- a** the combustion of hydrogen gas to form water
- b** the oxidation of zinc to form zinc oxide (ZnO)
- c** burning of magnesium ribbon to form magnesium oxide (MgO)

1.2 INVESTIGATING

Investigate your available resources (for example, textbooks, encyclopaedias, internet) to complete the following tasks.

1 Construct a chart or table that shows the metallic element or alloy that is used for each of the following. Include an image of the metal or alloy and why it is used for that purpose:

- the filament in old-fashioned incandescent light bulbs
- hot and cold water pipes
- it is used as film coating and turns black when exposed to light
- it is used in fireworks and single-use flash bulbs to give brilliant light
- part of haemoglobin; the part of our blood that carries oxygen
- added to 'super' petrol to avoid 'knocking'
- makes up the metal plates of a car battery
- is in the catalytic converters of car exhaust systems to remove pollutants
- it is used in smoke alarms as a radioactive source
- it is a radioactive element used in atomic bombs
- it is the metal that is used in many street lamps, giving an orange colouring

2 Research metal roof decking. Specifically:

- a** explain why roof decking is corrugated or 'ribbed'
- b** outline what is meant by 'Colorbond roofing'
- c** outline the advantages and disadvantages of various metal roofing materials.



Fig 1.2.12 The wire that makes up a filament is metal. Which one is it?

1.2 PRACTICAL ACTIVITIES

1 Complete and incomplete combustion

Aim

To examine the products of complete and incomplete combustion

Equipment

- ethanol
- Pasteur pipette
- kerosene with wick
- lab coat
- safety glasses
- heat mat
- watch-glass
- candle

Method

- 1 Light the candle and note things like the colour of the flame and any sign of soot.
- 2 Put a few drops of ethanol on a watch-glass and light it carefully. Observe the flame.
- 3 Light the kerosene burner and observe the flame.

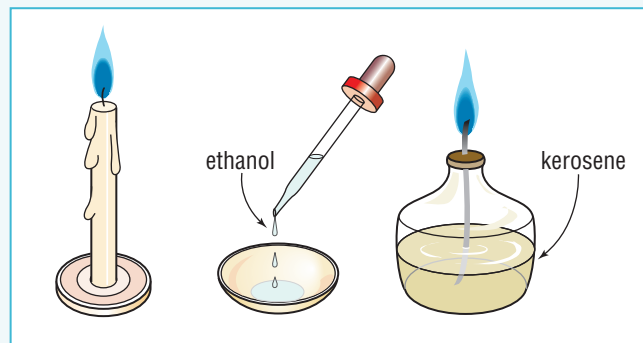

Fig 1.2.13

Questions

- 1 Describe any evidence observed for:
 - a complete combustion
 - b incomplete combustion.
- 2 The molecular formula of ethanol is C_2H_5OH . Kerosene is a mixture of hydrocarbons with an average formula of $C_{12}H_{26}$. Explain the difference in the way these compounds burned, in terms of their formulae.
- 3 Is the burning of petrol in cars an example of complete combustion or incomplete combustion? Justify your answer.

2 Corrosion of iron

Aim

To investigate factors affecting the corrosion of iron

Equipment

- 5 iron nails (not galvanised)
- copper wire
- magnesium ribbon
- distilled water
- salt (sodium chloride) solution
- fine sandpaper or steel wool
- 4 test tubes
- test-tube rack
- Bunsen burner
- bench mat and matches
- 250 mL beaker
- peg or tongs
- marking pen

Method

Part A

- 1 Polish a nail with sandpaper or steel wool.
- 2 Fill the 250 mL beaker with cold water.
- 3 Heat a nail in a blue Bunsen flame until red hot. Use the peg to drop it into the water. Record what happens.

Part B

- 4 Once again, polish four nails with sandpaper or steel wool.
- 5 Tightly wind the magnesium ribbon around a nail, and the copper wire around another nail.
- 6 Put both into test tubes containing salt water.
- 7 Put another two nails in the other two test tubes, marking which contains fresh water.
- 8 Leave for three or four days.
- 9 Draw each nail, showing the location of any reddish rust and any white corrosion on the magnesium or blue/green corrosion on the copper.

Questions

- Deduce** which factors encourage rusting.
- Describe** the effect of heat on the rate of rusting.
- List** all the metals used, in order from most to least reactive.

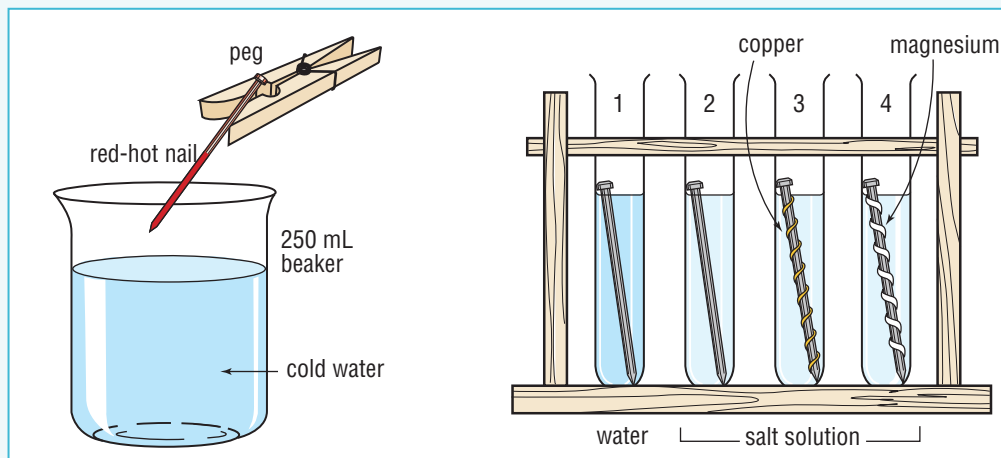

Fig 1.2.14

- Which test demonstrated sacrificial protection?
Justify your answer.
- Explain** why one metal sacrificed itself and not the other.

3 Observing iron hydroxides

Aim

To observe the difference between iron(II) hydroxide and iron(III) hydroxide

Equipment

- test-tube rack
- 2 test tubes
- Pasteur pipette
- 1 M sodium hydroxide (NaOH) solution
- 0.1 M iron(II) chloride (FeCl_2) solution
- 0.1 M iron(III) chloride (FeCl_3) solution

Method

- Fill one test tube with approximately 2 cm of iron(II) chloride solution and the other test tube with 2 cm of iron(III) chloride solution.
- Use the Pasteur pipette to add the sodium hydroxide solution dropwise to each test tube and record your results.

Questions

- Describe** what happened to the iron(II) chloride solution when you added the sodium hydroxide.
- Describe** what happened to the iron(III) chloride solution when you added the sodium hydroxide. How does the precipitate compare to rust-iron(III) oxide?
- Construct** balanced chemical equations for the reactions in both test tubes.

4

Anodised aluminium

Aim

To anodise a piece of aluminium

Equipment

- piece of aluminium
- aluminium foil
- 2 M sulfuric acid
- detergent
- fabric dye solution
- safety glasses
- two 250 mL beakers
- tongs
- tissues
- 12 V power pack with wires and alligator clips
- retort stand
- bosshead and clamp
- Bunsen burner
- tripod
- gauze mat
- bench mat and matches or hot plate

Method

- 1 Line one beaker with aluminium foil, then three-quarters fill it with sulfuric acid.
- 2 Scrub the piece of aluminium in warm water and detergent and dry well. Do not touch the aluminium with bare hands. Use tongs.
- 3 Place as shown in the diagram and connect to the power pack.
- 4 Set on the lowest voltage, then gradually increase until it reaches 12 V. Leave for 15 minutes, then wash the piece of aluminium in water.
- 5 In the other beaker, heat the prepared solution of fabric dye, then place the aluminium piece in it. Leave for 10 minutes.
- 6 Rinse in fresh water and cool.
- 7 To seal the anodised surface, boil the piece in fresh water for a further 10 minutes.

Questions

- 1 **Explain** why the aluminium piece must be handled only with tongs after cleaning.
- 2 Aluminium is highly reactive but doesn't seem to corrode as badly as iron. **Explain** why.
- 3 **Describe** what anodising produced.
- 4 **Explain** why anodising would not work with iron.

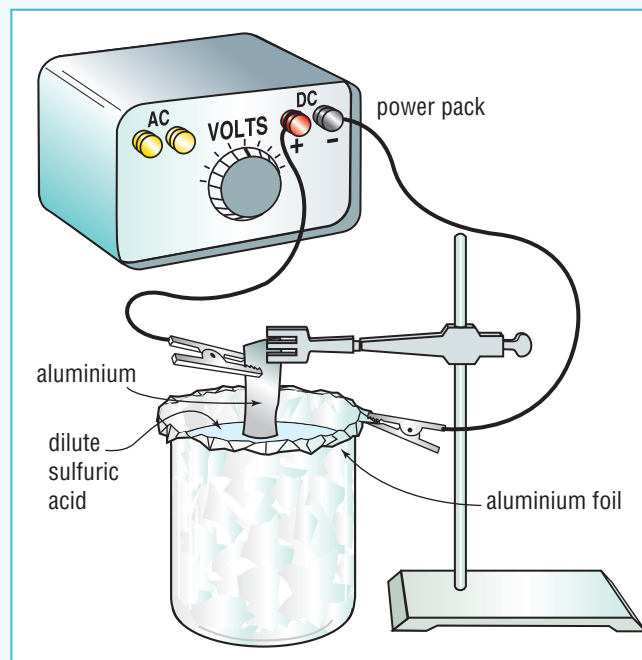

Fig 1.2.15

context

New substances are formed in both chemical and nuclear reactions. In a chemical reaction, the new substance is formed by simply rearranging the atoms to form new elements or compounds. The atoms themselves remain unchanged. However, in a nuclear reaction, the internal structure of the

atom changes and different types of atoms are formed. This change is usually accompanied by nuclear radiation which can be very harmful to biological materials. If controlled, this nuclear radiation can be used for medical diagnosis and treatment and for generating huge amounts of power in nuclear power stations.

Radiation and radioactivity

There are 92 protons in the nuclei of uranium atoms. They are all positively charged and each one repels the others. Logic says they should fly apart and the nucleus should disintegrate into 92 parts. But this doesn't happen. Protons in a nucleus stay together because of another more powerful force, called the **nuclear force**. Nuclear force acts between all particles in a nucleus and is more than sufficient to hold the nuclei of small atoms together. When a nucleus becomes very large, however, the nuclear force may not be strong enough to hold the nucleus together and bits might break off. In doing so, the nucleus gets smaller and more stable. Nuclear radiation is the energy and the particles that are released from the nucleus in its break-up. An element with atoms that emit nuclear radiation is said to be **radioactive**. Uranium and most of the elements after it in the periodic table (atoms of higher atomic number) are radioactive.

Atoms and isotopes

Atoms with the same number of protons belong to the same element. **Isotopes** are atoms of the same element that have different numbers of neutrons in their nuclei.

For example, all lithium atoms have three protons. Ninety-three per cent of all lithium atoms have three neutrons. The rest have four. Hence lithium has two isotopes, which we can write as:

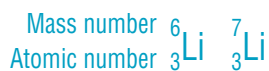

Uranium atoms always have 92 protons. The most common isotope has 146 neutrons, a less common isotope has 143 neutrons and a few have 142 neutrons. Hence they can be written as:

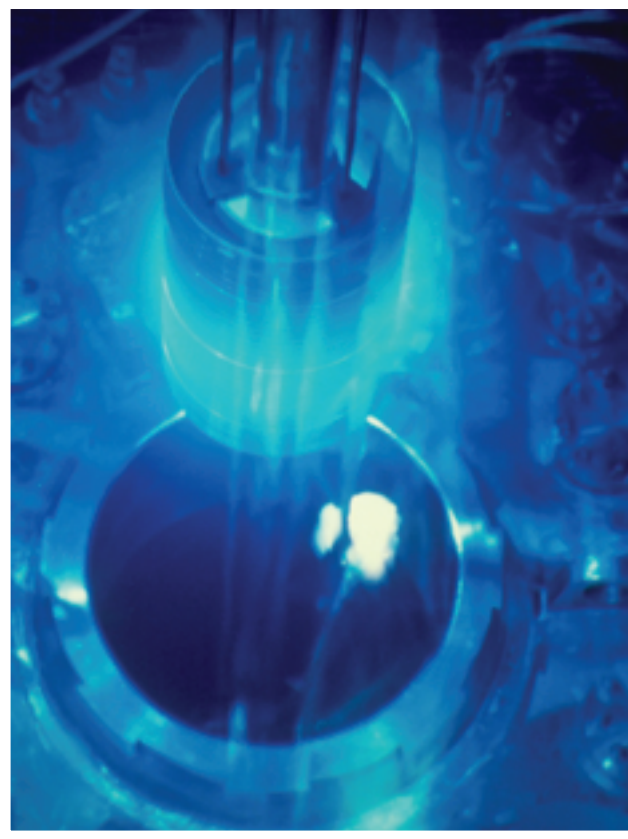

Fig 1.3.1 Underwater fuel rods being removed from a nuclear reactor—the blue glow is called Cerenkov radiation and is caused by nuclear radiation in the water.

Science Fact File

A radioactive discovery

In 1896, French scientist Henri Becquerel placed some uranium in a dark drawer containing some wrapped photographic plates. He was surprised to find later that the plates had become foggy. He deduced that they must have been affected by something coming from the uranium, something able to penetrate the wrapping. He had observed one effect of radioactivity.

Radioisotopes

A radioactive isotope is called a **radioisotope**. When referring to a radioisotope, we often give just its **mass number**. Because all uranium atoms are radioactive, the radioisotopes of uranium could be written as uranium-234, uranium-235 and uranium-238. Actinium, astatine, carbon, francium, thorium, protactinium, polonium, radon and radium are all radioactive elements and, like uranium, occur naturally. Many synthetic or 'artificial' elements are also radioactive.

Hydrogen has three isotopes. Approximately 99 per cent is 'normal' (stable and not radioactive), one per cent is deuterium (stable but toxic in high doses) and a few are tritium. Tritium is unstable—it is a radioisotope.

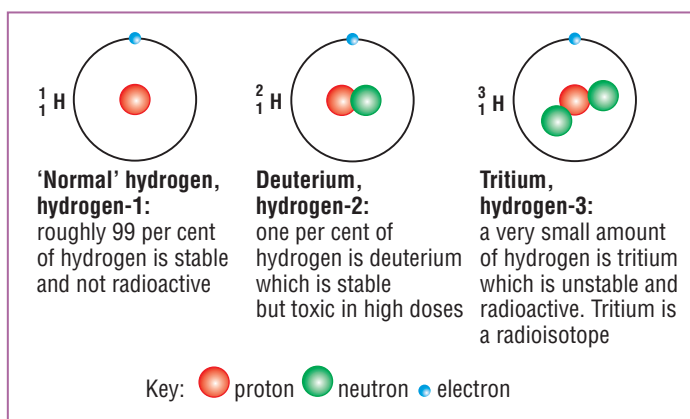

Fig 1.3.2 Three isotopes of hydrogen

Three types of nuclear radiation

There are three types of nuclear radiation coming from three types of nuclear reactions. When a radioisotope emits radiation, it usually transforms into another element. It is said to undergo radioactive decay. There are three main types of **radioactive decay**, each emitting a different type of radiation:

- alpha radiation
- beta radiation
- gamma radiation.

Alpha radiation

One way in which radioactive nuclei can get smaller and more stable is by throwing out a cluster of two protons and two neutrons. This cluster is known as an **alpha particle** (denoted by α), but is really just a helium nucleus, ${}^4_2\text{He}$.

Uranium-238 emits an alpha particle and in doing so decays into thorium-234.

The equation is balanced, with the same number of protons and neutrons on each side. You can check by adding up the mass numbers on the product side of the

reaction: they add up to 238, the same as we started with. Likewise, the atomic numbers add up to 92.

Alpha particles move at speeds of up to one-tenth the speed of light. Alpha decay can be thought of as **nuclear fission**, since a **parent nucleus** splits into two **daughter nuclei**.

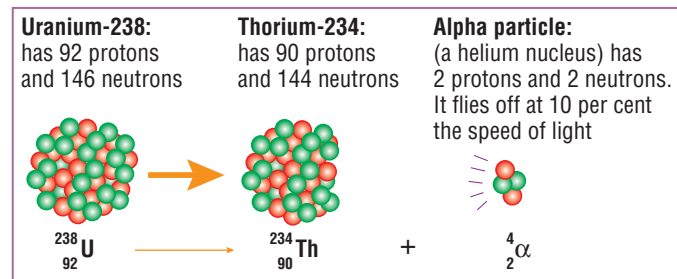

Fig 1.3.3 Alpha decay

Beta radiation

When there is an imbalance of neutrons and protons in a nucleus, a neutron may change into a proton and an electron. The newly created electron is called a **beta particle** (denoted by β) which is then emitted from the nucleus.

Science Fact File

Marie and Pierre Curie

Polish-born Marie Curie and her French-born husband Pierre Curie are famous for their pioneering work with uranium and other radiation-emitting elements. Marie was first to use the term 'radioactivity', her birthplace gave us the name for the element polonium, Po, and the Curies' surname became the name for curium, Cm. The couple shared the 1903 Nobel Prize for physics with Henri Becquerel. In 1911, Marie became the first person to win two Nobel Prizes when she was awarded the Nobel Prize for chemistry for her discovery of radium and polonium. Pierre was killed in an accident with a horse-drawn vehicle in 1906 and Marie died of leukemia in 1934, probably as a result of working so closely with radioisotopes for most of her life.



Fig 1.3.4 Physicists Pierre and Marie Curie

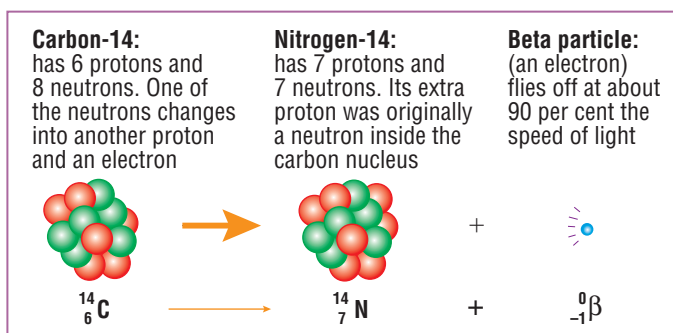

Fig 1.3.5 Beta decay

Carbon-14 is a radioisotope that decays into a new element, nitrogen, by emitting a beta particle from its nucleus.

An extra proton has been created from a neutron, so the atomic number of the atom increases from 6 to 7, meaning that a new element has been formed. The mass number of the beta particle is zero as it really is just an electron, and they have negligible mass. The -1 at the bottom indicates the negative charge on a beta particle. Once again, the atomic numbers give the same total ($6 = 7 + -1$).

Beta particles move at speeds of up to nine-tenths the speed of light and so pass through materials better than alpha particles.

Gamma radiation

Both alpha and beta radiation consist of particles. Earlier it was mentioned that radiation may also be in the form of electromagnetic waves or rays. Sometimes when an alpha particle or beta particle is emitted from a nucleus, the new nucleus is still unstable, and emits extra energy in the form of a **gamma ray** to become more stable. A gamma ray (denoted by γ) is a burst of high-frequency electromagnetic radiation that has no mass or charge. Gamma rays are more powerful than X-rays.

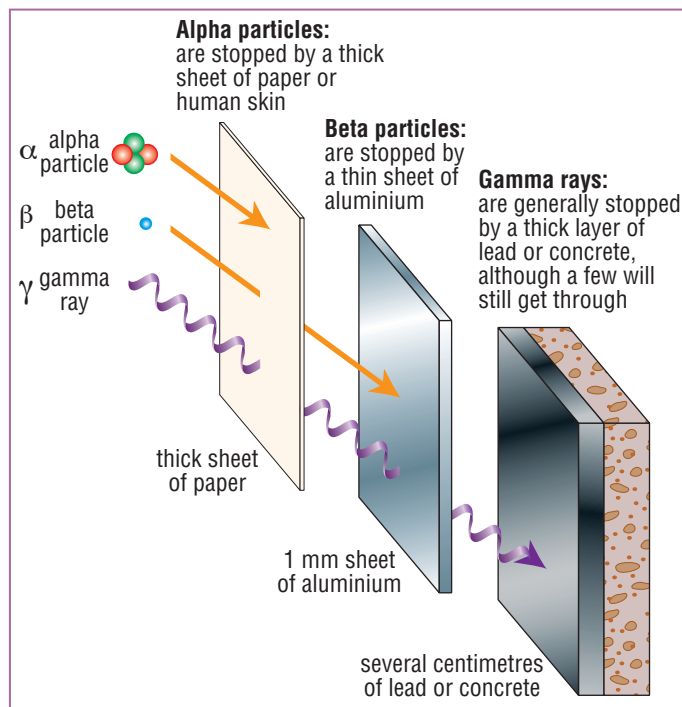

Fig 1.3.7 The penetration abilities of alpha, beta and gamma radiation

The beta decay of iodine-131 is accompanied by gamma emission.

Like all electromagnetic radiation, gamma rays move at the speed of light (300 000 km/s). They penetrate materials even more than beta particles.



Worksheet 1.6 Uranium decay series

Half-life

The time required for half of the atoms in any given quantity of a radioactive isotope to decay is the **half-life** of that isotope. Each particular isotope has its own half-life. Some common radioisotopes and their half-lives are shown here.

Radioisotope	Half-life
Radon-222	4 days
Iodine-131	8 days
Cobalt-60	5.3 years
Americium-241	460 years
Carbon-14	5730 years
Plutonium-239	24 000 years
Uranium-238	4.5 million years

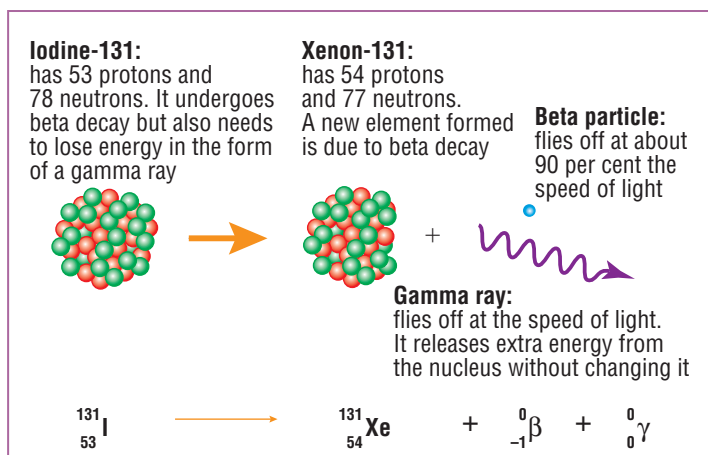

Fig 1.3.6 Gamma decay

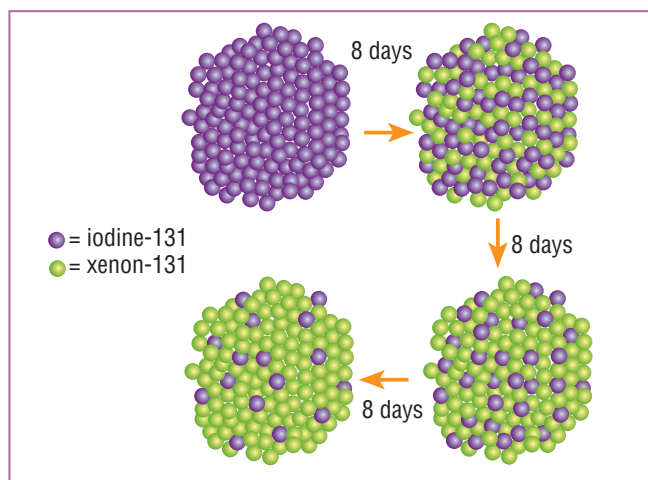

Fig 1.3.8 Iodine-131 has a half-life of eight days. This means that the number of iodine atoms halves every eight days.

A 1-kilogram sample of pure uranium-238 would decay over time to leave the following amounts.

Time	Mass of U-238 in sample
0 years	1 kg
4.5 million years	500 g
9 million years	250 g
13.5 million years	125 g
18 million years	62.5 g



Sources of nuclear radiation

Nuclear radiation may be produced artificially by bombarding atoms with neutrons or other subatomic particles. Most radiation we receive, however, comes from natural sources. The Earth is continually being struck by **solar radiation** and **cosmic radiation** produced, for example, by collapsing stars. **Terrestrial radiation** originates from substances in the Earth's crust. The decay of natural underground uranium produces radioactive **radon gas**, which you inhale from the air around you.

Effects of radiation

Alpha, beta and gamma radiation are sometimes called **ionising radiation** because of their ability to **ionise** (knock electrons off) atoms or molecules, causing them to become charged. Charged atoms or molecules are called ions. Alpha particles have high ionising ability, while beta and gamma radiation have low ionising ability.



75%

Terrestrial (from natural radioactive underground deposits)

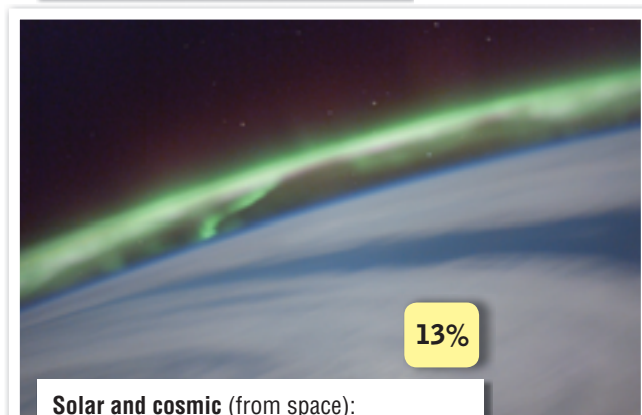

13%

Solar and cosmic (from space): auroras are caused when solar radiation strikes the upper atmosphere near the poles



10%

Medical (from medical procedures and X-rays)

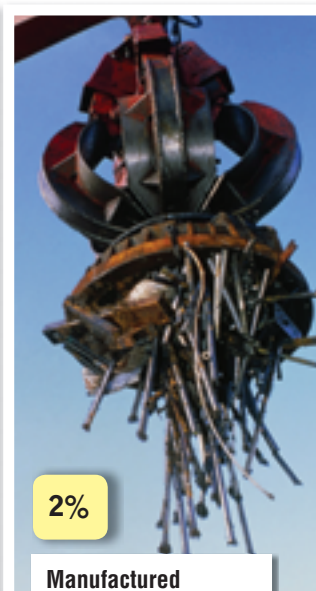

2%

Manufactured (from burning coal, electromagnetic devices, fallout from weapons testing)

Fig 1.3.9 Sources of nuclear radiation showing the percentages of each received by an 'average' person.

Because ions attract other atoms and molecules, they are more likely to become involved in chemical reactions. If these radiations hit body cells, they may cause chemical reactions that can:

- destroy cells—this may appear as a ‘burn’. Cells on that site may not be replaced
- cause abnormal cell growth—this may appear as a **tumour** or **cancer**.

Measuring radiation

Nuclear radiation may be detected using a **Geiger counter**. Gas molecules within a tube are ionised by any radiation that enters. The resulting ions produce a pulse of electrical current that is fed to a small speaker and counter. The speaker makes a clicking sound with each pulse of current. The **activity** of a radioactive sample is the number of disintegrations per second, and gives an indication of the number of radioisotopes present. People working in areas of high radiation levels, such as at nuclear facilities, wear special detectors called **dosimeters**.

There are several units for measuring nuclear radiation doses. One of the main units is **sieverts (Sv)**. The table below refers to millionths of a sievert, or **microsieverts (μSv)**.

A dose measured in sieverts or microsieverts takes into account the energy per kilogram ‘delivered’ by nuclear radiation and its ability to ionise. You receive a dose of about 300 μSv annually from cosmic radiation, and 1400 μSv from terrestrial radiation. The following table shows the biological effects of nuclear radiation.



Fig 1.3.10 A researcher using a Geiger counter to monitor radiation

Science Clip

Radioactive water

In Fujian province in China, millions of people obtain drinking water from wells in granite rock. Radon-222 leaches from the granite into the water, making it 150 times more radioactive than water in more developed countries. Not surprisingly, cancer rates in the region are the highest in China.

Science Clip

Radioactive money!

Between 1945 and 1989, Germany was divided into two separate countries (East and West Germany). As part of the ‘cold war’, East German secret police used radioactive scandium-46 to invisibly label political opponents so they could be tracked using hidden Geiger counters that vibrated in response to radioactivity. Labelling occurred in a variety of ways. Floors were treated, as were documents and money. This practice exposed victims and anyone near them to dangerous levels of radioactivity, since scandium-46 is both a beta and a gamma emitter. Radioactive cash in your pocket would both give you away to the secret police and very likely reduce your fertility!

Dose (μSv)	Short-term effects	Long-term effects
Less than 10 000	None	Possible effects on unborn babies
10 000 to 100 000	None	Unborn babies likely to contract leukaemia
100 000 to 500 000	Cell damage	Increased likelihood of cancer (including leukaemia)
500 000 to 1 000 000	Radiation sickness: symptoms include nausea, vomiting, diarrhoea, hair loss, internal bleeding; white blood cell count drops	Greater likelihood of contracting cancer
1 000 000 to 8 000 000	Severe radiation sickness, possible death within a month	Very high probability of developing cancer

Uses of nuclear radiation

Nuclear medicine

Nuclear radiation is not always bad. Radioisotopes can cause cancers but are also used in nuclear medicine to diagnose and treat them. **Radiotherapy** involves directing high, localised doses of radiation to cancer sites by using an external focused beam or a surgical implant, or by swallowing a radioactive medicine. Rapidly dividing cells such as cancerous cells are more sensitive to nuclear radiation than other cells—they self-destruct if their DNA is damaged. Unfortunately, some nearby healthy cells are also killed, leading to short-term illness and side-effects.

Nuclear medicines are also used to give images of internal organs, blood vessels and bones. Gamma-emitting **radioactive tracers** are swallowed or injected and tend to collect in particular parts of the body. They are then detected by a gamma ray camera placed outside the body. The gamma rays coming from inside the body are then converted to an image. For example, iodine-123 concentrates in the thyroid gland and so may be used to help diagnose thyroid conditions.



Fig 1.3.11 Cobalt-60 is commonly used as a source of gamma rays to treat localised secondary cancers. This device directs gamma rays onto cancerous growths.

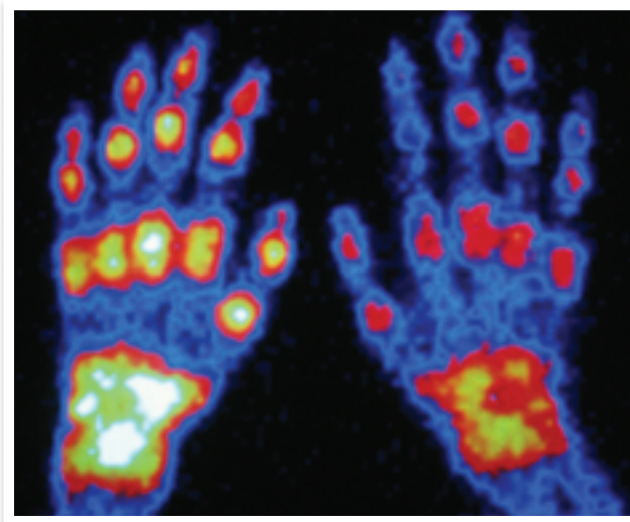

Fig 1.3.12 The hands of a person with severe rheumatoid arthritis. Technetium-99m has gathered in the affected areas and the gamma rays it emits have been captured in this image.

Industrial applications

Nuclear radiation can be added to liquids or gases flowing in pipes to trace leaks or check for fractures. The thickness of metal or rubber sheets can be verified by measuring the amount of radiation transmitted through the material.

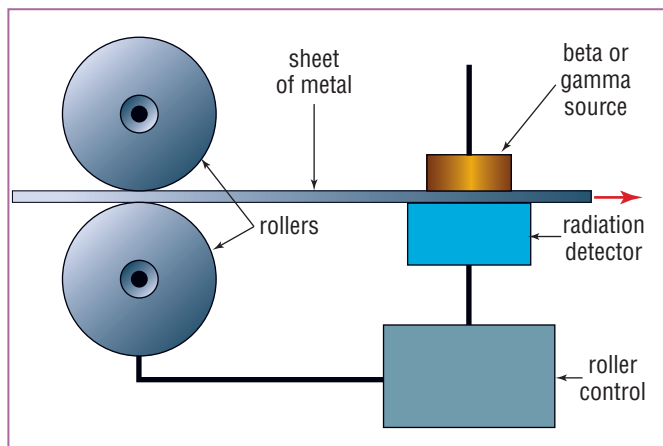

Fig 1.3.13 Radiation may be used to check the thickness of materials.

Science Clip

Golden pool!

The source of the balls of matter washing up on Sydney beaches was uncertain. Did they come from sewage or another source such as waste from a passing tanker? Scientists 'labelled' outgoing sewage with radioactive gold-198, a radioisotope with a half-life of 2.7 days. Soon after, the balls washing up on beaches were found to be radioactive, showing that they indeed came from discharged sewage.

Carbon dating

All living things contain radioactive carbon-14. It is continually decaying, but is constantly being replenished. While the organism is alive, the percentage of carbon-14 it contains will remain constant.

When an organism dies, the amount of carbon-14 reduces due to its continuous beta decay into nitrogen-14. In contrast, the amount of normal non-radioactive carbon (carbon-12) stays constant. The approximate age of once-living matter can be determined by comparing the amounts of both types of carbon in it and then using the graph shown in Figure 1.3.14.

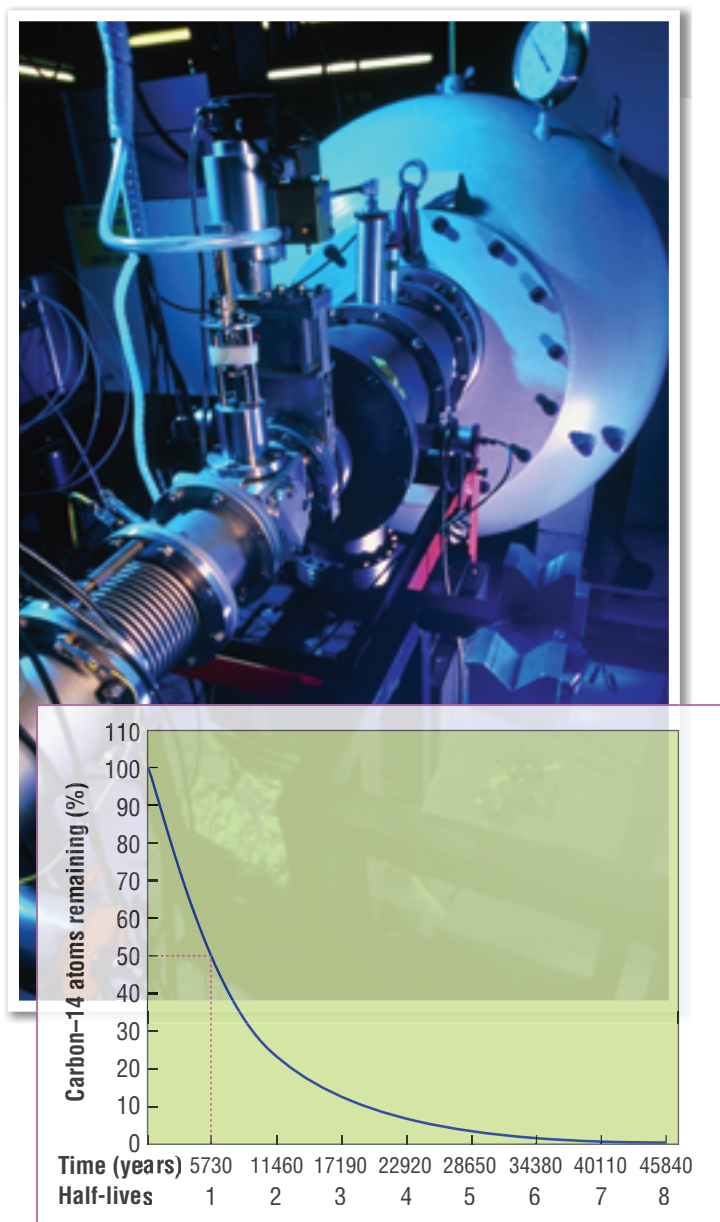

Fig 1.3.14 A linear accelerator (above) and the graph used to carbon-date matter that was once living

Dirty bombs

A **dirty bomb** is not a traditional nuclear bomb. It is basically any bomb that has radioactive material such as nuclear waste in it. This radioactive material is spread as very fine particles across large areas when the bomb explodes, floating in the air and contaminating water and food. It is impossible to clean up the radioactive material and it can cause contamination problems for hundreds of years. There has been concern about terrorist organisations using dirty bombs and therefore it is important that radioactive waste is tightly controlled to ensure this does not happen.

Other uses

Food that has been exposed to gamma radiation lasts much longer than normal, without becoming radioactive itself. Bacteria and fungi are killed by the radiation, but vitamins may also be destroyed and new chemicals might be created within the food. For this reason, many consumers are uncomfortable with the idea of **food irradiation**.

Nuclear radiation is also used to sterilise medical and surgical equipment. Needles used by diabetics are sterilised in this way.

Radioisotopes can be injected into or fed to animals in order to trace their movement using radiation detectors, or to trace the movement of nutrients through the food chain.

Fertilisers with added radioisotopes are used to study the uptake of nutrients by crops.

Radioactive material left over from nuclear power generation is used to make nuclear bombs and ammunition that can pierce the heavy armour of tanks.

Go to Science Focus 4 Unit 8.3



Science Fact File

Smoke detectors

Smoke detectors contain a small amount of americium-241. Alpha particles emitted by the americium ionise the air and create a small current, which keeps the alarm from sounding. When smoke enters, the ions are attracted to the larger smoke particles and move more slowly. The reduced current is then unable to stop the alarm sounding, and a high-pitched sound is emitted.

1.3 QUESTIONS

Remembering

- List the three main types of radiation.
- State the type of force that acts on particles in the nucleus of an atom to:
 - hold them together
 - push them apart
- List four radioactive elements.
- List two natural ways in which radiation is produced.
- State the size of the radiation dose you are likely to receive over the next year.
- List two uses of nuclear radiation in industry.

Understanding

- Define the terms:
 - radioisotope
 - half-life
- Explain why large atoms are more likely to be radioactive than small ones.
- Explain why ions produced by radiation are more likely to affect our cells than other atoms.
- Describe two ways nuclear radiation may be detected.
- Describe an advantage and a disadvantage of food irradiation.
- Gold-198 does not exist naturally. Describe how it can be made.

Applying

- Identify which atom is an isotope of atom ${}_{20}^{40}\text{X}$. Is it atom ${}_{22}^{42}\text{Y}$ or atom ${}_{20}^{42}\text{Z}$?
- Identify the type of nuclear radiation that:
 - is the same as in a helium nucleus
 - can pass through paper but not aluminium
 - is not made of particles
 - requires the conversion of a neutron into a proton and an electron
 - is the product of nuclear fission

Analysing

- For the three radiation types, contrast:
 - the physical size of the emitted particles (if any)
 - their speeds
 - their penetrating abilities
- Iodine-131 has a half-life of 8 days. Calculate the amount left from a 2 kg sample after:
 - 8 days
 - 16 days
 - 24 days **N**
- Calculate the missing number in the following nuclear reactions:
 - ${}_{84}^{218}\text{Po} \rightarrow \text{--- Pb} + {}_2^4\alpha$
 - ${}_{11}^{24}\text{Na} \rightarrow \text{--- Mg} + {}_1^0\beta$
 - ${}_{54}^{133}\text{Xe} \rightarrow \text{--- Xe} + \gamma$
 - ${}_{26}^{59}\text{Fe} \rightarrow \text{--- Co} + {}_{-1}^0\beta + \gamma$ **N**

Evaluating

- Radioactive decay of uranium in the ground produces radon gas, which bubbles up through the ground to reach the air. Radon in turn decays to produce polonium, an alpha particle emitter. Although alpha particles cannot penetrate the skin, uranium-miners are at increased risk of radiation diseases. Propose why.
- Propose two reasons why alpha particles are never injected for medical diagnosis.
- Propose a reason why hair cells are often damaged during radiation therapy.
- Evaluate the danger of the following doses of radiation:
 - 1 microsievert received in a short burst
 - 500 microsieverts received over the course of a year
 - 100 000 microsieverts received in a short burst

Creating

- Construct a pie graph, a stacked bar graph or a column graph showing the percentage of radiation we receive from major sources. **N**

1.3 INVESTIGATING

Investigate your available resources (for example, textbooks, encyclopaedias, internet) to complete the following tasks.

- 1 Research the lives of the Curies and use a timeline to summarise key events in their lives. **N**
- 2 **a** Research other methods of nuclear radiation detection such as film badges or cloud chambers. Use a labelled diagram to explain the workings of one method.
b There are a large number of units for measuring nuclear radiation including gray, rem, rad, Curie, Becquerel and roentgen. Explain what one of these really means, and give the abbreviation for the unit.
- 3 Choose one example where a PET scan is used. With the aid of a diagram, explain how it works.
- 4 **a** Explain what the Shroud of Turin is.
b Explain how carbon dating has been used to date the Shroud.
c Use this evidence to deduce the age and authenticity of the Shroud.
- 5 **a** **Investigate** dirty bombs and how they work.
b Discuss whether this type of terrorist attack is likely, supporting your information with evidence. **L**

1.3 PRACTICAL ACTIVITIES



1 Half-life is sweet

Aim

To model radioactive decay and half-life

Equipment

- packet of M&Ms (or Skittles)
- a clean tray or sheet of A3 paper
- a clean jar

Method

- 1 Count the total number of M&Ms in the packet and put them into the jar.
- 2 Pour the jar of M&Ms onto the clean tray or onto A3 paper.

- 3 Count how many M&Ms show the letter M, record this number in a table like the one shown below.

Number of repeats	1	2	3	4	5
M&Ms showing the letter M					

- 4 Place only the M&Ms showing the letter M back into the jar and dispose of the other M&Ms appropriately.
- 5 Repeat this procedure until there are no M&Ms left in the jar.

Questions

- 1 **Construct** a graph of the number of M&Ms versus the number of times the procedure was repeated.
- 2 **Compile** everyone's results into one table and plot the classroom total of M&Ms with each repeat of the procedure. **N**
- 3 **Describe** the shape of the graphs that you have produced and **discuss** how this models the half-life of a radioactive element.

CHAPTER REVIEW

Remembering

- 1 List** the possible states in which chemicals may exist and list the symbols used for them in an equation.
- 2 Write** a chemical equation and specify the reactants and products, states of each substance, correctly written formulae, and numbers balancing the equation.
- 3 State** one thing that could make a reaction go faster, besides using a catalyst.

Understanding

- 4 Explain** why scientists use chemical equations and the information contained within chemical equations.
- 5 Explain** whether SO_2 or Na_2SO_4 is a molecular formula and explain your answer.
- 6 Describe** in words what these equations are showing:
 - a** $2\text{Na} + 2\text{H}_2\text{O} \rightarrow \text{H}_2 + 2\text{NaOH}$
 - b** $\text{CuO} + 2\text{HNO}_3 \rightarrow \text{Cu}(\text{NO}_3)_2 + \text{H}_2\text{O}$
- 7 Describe** and contrast complete and incomplete combustion.
- 8 Copy** the following table and **summarise** the details for each of the main types of nuclear radiation.

	Alpha particles	Beta particles	Gamma rays
Sketch			
Charge			
Mass			
Speed			
Penetration ability (high, medium or low)			
Stopped by ionising ability			

- 9 Explain** why radiotherapy harms cancer cells more than healthy cells.
- 10 Outline** how nuclear radiation is used to obtain images of internal organs.
- 11 Explain** why young children are more likely to be affected by radiation doses than adults.
- 12 Radon** gas is present in our atmosphere. **Outline** how it is produced.

Applying

- 13 Solid lithium carbonate** reacts with dilute hydrochloric acid to produce a salt, water and carbon dioxide.
 - a Identify** the likely salt produced.
 - b Write** a word equation for the reaction.
 - c Write** a balanced formula equation for it, with subscripts indicating the states of each chemical.

Analysing

- 14 Analyse** the following equations and balance them:
 - a** $\text{Al}(\text{OH})_3 + \text{HNO}_3 \rightarrow \text{H}_2\text{O} + \text{Al}(\text{NO}_3)_3$
 - b** $\text{H}_2\text{O} + \text{K} \rightarrow \text{H}_2 + \text{KOH}$
- 15 Analyse** the reactions below to determine:
 - a** the word equation
 - b** the balanced formula equation, including states.
 - i** Dilute hydrochloric acid reacts with a lump of potassium hydroxide to produce water containing dissolved potassium chloride
 - ii** Sulfur dioxide is added to oxygen, producing sulfur trioxide gas
 - ii** Solid magnesium combines with chlorine gas to produce solid magnesium chloride
 - iv** Silver nitrate solution is added to sodium chloride solution, producing sodium nitrate solution and a precipitate of silver chloride
- 16 Calculate** the fraction of a sample of pure radon-222 that would remain after 12 days. **N**
- 17 A fossil** is found to contain one-sixteenth of the amount of carbon-14 of a living specimen. **Calculate** the age of the fossil. **N**

Evaluating

- 18 Propose** why aluminium would not be a good choice to protect iron by sacrificial protection, even though aluminium is higher on the activity series.
- 19 Would** an alpha particle emitter be suitable for measuring the thickness of cardboard in a packaging manufacturing plant? **Justify** your answer.
- 20 In the Gulf War**, ammunition made of depleted uranium was used to pierce tanks. Burning uranium from such ammunition forms tiny particles that may be inhaled. **Propose** why this is of concern even today, more than 10 years after the war.
- 21 Assess** whether the radioactivity of a sample of plutonium would be very different after 10 years.

Creating

- 22 Construct** a simplified flow chart to demonstrate the four steps in the contact process.



Worksheet 1.7 Crossword



Worksheet 1.8 Sci-words



Materials

2

Prescribed focus area

The implications of science for society and the environment

Key outcomes

5.4, 5.7.3, 5.10, 5.11.1, 5.11.2, 5.12

- Technology has created new materials such as metal alloys, plastics and synthetic fibres.
 - Metals are a natural resource and the mining of metals is important to Australia economically.
 - It is important to balance human activities and needs with maintaining the quality and sustainability of the environment.
 - Technology has allowed the development of materials that are more convenient.
-
- It is important to balance the economic and environmental impacts of mining and resource exploration.
 - The costs and benefits of mining on communities and the environment must be considered before any mining is considered.
 - The properties of synthetic materials such as plastics and synthetic fibres are often superior to those of naturally derived materials in different situations.
 - Aboriginal people used natural resins and fibres in the production of weapons, tools, cloth and string.
 - Common reactions involving organic compounds include esterification and saponification.

Essentials

Additional

context

A **material** is any substance that can be used to manufacture useful products such as clothes, Wii players, cars, tools, ice-cream, shampoos and most of what is around you. Some materials like wood, wool, cotton and gold occur naturally and

only need a little cleaning up before they can be used. Other materials such as iron, aluminium, brass, glass, paper and soap are made by processing natural materials. Many of the materials of the modern world such as plastics, nylon and laminex are synthesised entirely in a laboratory or in chemical plants. Metals are some of our most important materials. Iron and steel are used to reinforce concrete, to build bridges, cars and ships. Aircraft are covered in aluminium, gold and silver are used for jewellery, and stainless steel is used for body piercings. Metals are useful because of their unique chemical and physical properties.



Fig 2.1.1 Artificial hip joints need to be strong, non-toxic, corrosion-resistant and made from a material that is unlikely to be rejected by the body. For this reason they are made from metal alloys of titanium, cobalt or chrome.

Metallic bonding

The unique properties of metals can be explained by how the atoms in metals are bonded together. In a solid piece of metal the atoms form a very tightly packed crystal lattice. This is why most metals are dense, making most sink when thrown into water. Each of the atoms in a lattice releases its outermost electrons which are then free to move around the entire lattice. It is the mobility of these electrons that give metals their special properties.



Go to [Science Focus 3 Unit 2.3](#)

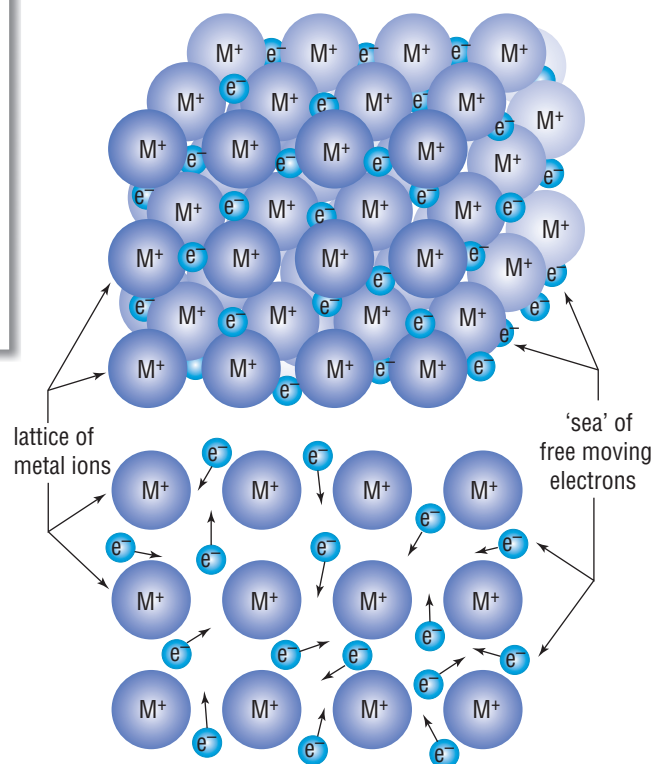
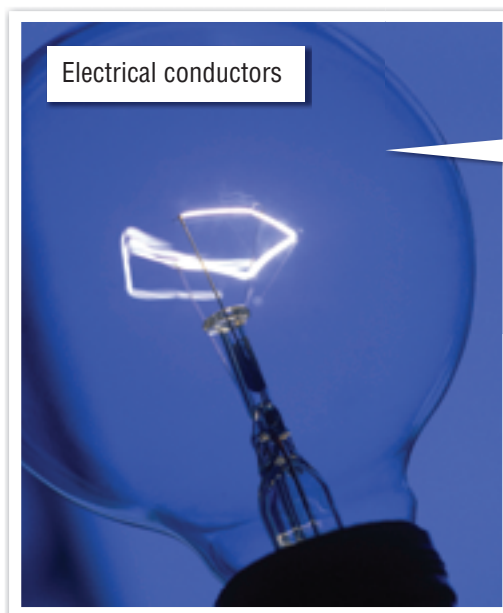
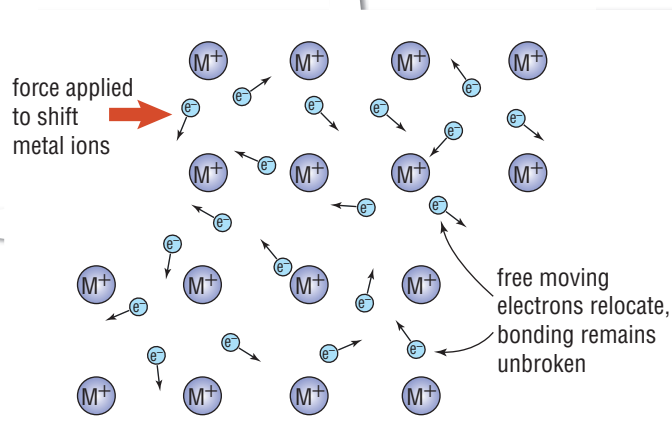
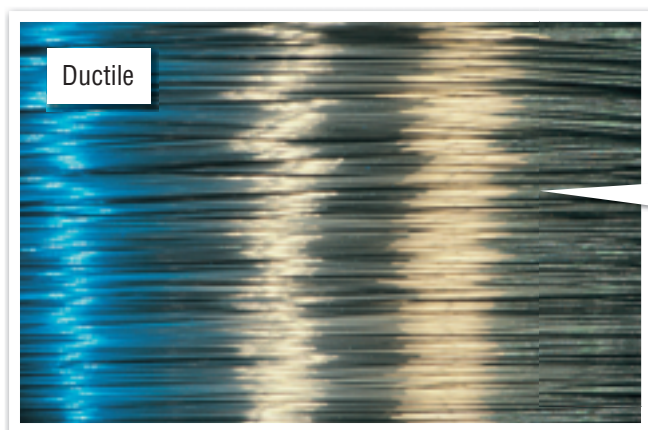

Fig 2.1.2 Metals are held together by electrostatic attraction between the lattice of metal ions and the 'sea' of electrons that are free to move around them.

Properties of metals

There are many different types of metals. Each metal has its own special properties that make it useful in different situations. However, all metals share some very special properties that cannot be found in non-metallic materials. Most metals are:

- **malleable**—metals will not break apart when hammered into sheets or bent
- **ductile**—this is the ability to be **drawn** or stretched into wires for electronic circuits
- excellent **electrical conductors**—metals carry electrical currents very easily, even at very low temperatures
- excellent **heat conductors**—heat travels quickly through a metal.



Electrons can carry current

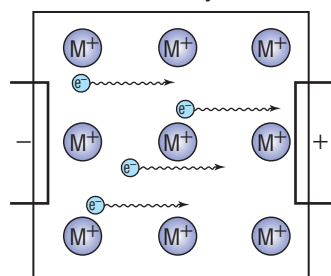

Electrons rapidly transfer heat

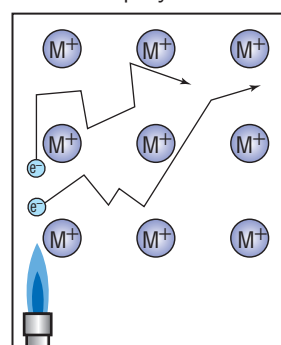

Fig 2.1.3 Metals are dense, malleable, ductile and good conductors of heat and electricity. Each of these properties can be explained by what is happening to the electrons and the lattice of ions in the metal.

Pure metals

Pure metals have not been mixed with any other elements. These metals contain only one type of atom, such as a nugget of gold which only contains gold atoms. Although there are 94 metallic elements in the periodic table, only a few are ever used in their pure form—some of these are shown in the table below.



Alloys

An **alloy** consists of a metal (referred to as the **base metal**) combined with other elements. By mixing a metal with other elements, it is possible to customise and improve its physical properties such as melting point, strength or corrosion resistance. For example, pure iron is extremely soft, but its strength increases dramatically if small amounts of carbon are added. The alloy formed is steel. Different alloys of steel have different amounts of carbon in them:

- **mild steel** has a carbon content of 0.5 per cent
- **tool steel** is about 1 per cent carbon
- **cast iron** has a carbon content of between 2.4 per cent and 4.5 per cent. Cast iron is strong but brittle and shatters easily if hit or dropped.

Stainless steel has chromium (20 per cent) and nickel (10 per cent) added to stop rusting.

Pure gold jewellery would break if it was used for normal everyday wear. Instead, it is alloyed with silver or copper to increase its strength. The carat scale



Fig 2.1.4 Cast iron lace is very hard and very brittle.

measures the amount of pure gold in jewellery, with pure gold rated as 24 carat. Jewellery is often 18 carat, meaning that it is 18/24 (three-quarters or 75 per cent) gold. Some common alloys are listed in the table on page 39.

Science Clip

Wanted: muscular slave for short job!

Damascus steel was used in the ancient world to manufacture swords of extreme strength. The exact technology was lost about 200 years ago but one recipe calls for 'normal' steel to be heated, then cooled in two stages. The final cooling was supposedly achieved by thrusting the sword into the body of a 'muscular slave'. The strength of the slave apparently transferred on his death into the metal!

Pure metal	Element symbol	Uses	Properties that make it particularly suited to its use
Aluminium	Al	Overhead electricity cables, saucepans and cans, aluminium foil	Excellent conductor of heat and electricity, extremely light, non-toxic
Copper	Cu	Electrical wiring	Excellent electrical conductor, easily drawn into wires
Sodium	Na	Nuclear reactant Cooler	Conducts heat well, melts at 98°C, allowing molten sodium to flow along pipes in the reactor
Zinc	Zn	Coating for iron (forming galvanised iron)	Protects iron from rusting
Tin	Sn	Coating for steel cans for food, liquid, etc.	Stops steel from rusting, non-toxic, unreactive
Mercury	Hg	Thermometers	Liquid at room temperature, expands rapidly when heated, leaves tubes clean once it retreats, leaving no traces
Lead	Pb	Flashing around windows and rooftops to stop water entry	Very soft and easily bent, resists corrosion



Fig 2.1.5 Jewellery used for body piercings is usually rust-resistant, surgical-grade stainless steel. Infection can still occur.

Science Fact File

Money, money, money!

Australian 'gold' \$1 and \$2 coins contain 92 per cent copper, 6 per cent aluminium, 2 per cent nickel and no gold. The 'silver' coins are 25 per cent nickel, 75 per cent copper and no silver. Metal was first used as money in about 2000 BCE, but 'coins' were not invented until 600 BCE in Lydia, Anatolia. They were crude beads of electrum, a naturally occurring alloy of silver and gold.

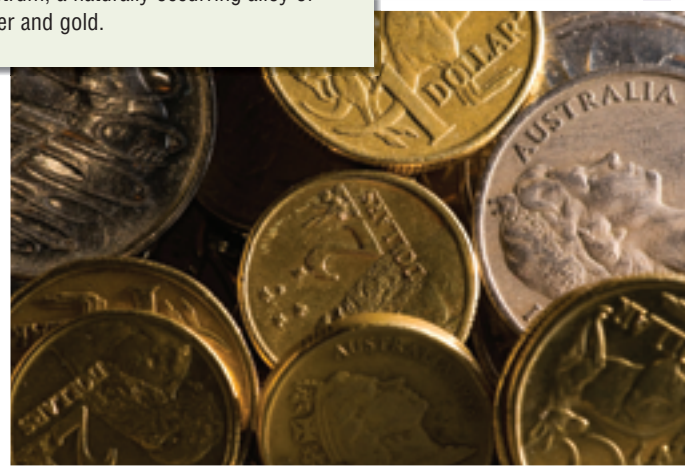

Fig 2.1.7 Australian coins are alloys of copper, aluminium and nickel.

Science Clip

Gold cheaper than iron!

When the Egyptian Pharaoh Tutankhamen was buried 3400 years ago, two daggers were buried with him. One dagger had a blade of gold, the other iron. Because of the rarity of iron at that time, the iron dagger was far more valuable than the gold one!

Fig 2.1.6 In Tutankhamen's time, iron was far more valuable than gold.

Worksheet 2.1 Toothache!

Worksheet 2.2 Media analysis



Alloy	Composition	Uses	Advantages
Brass	70% Cu, 30% Zn	Household and nautical fittings, musical instruments	Appearance, limited corrosion, harder than pure copper
Bronze	95% Cu, 5% Sn	Statues, ornaments, bells	Appearance, little corrosion, harder than brass, sonorous (rings well when struck)
Duralumin	96% Al, 4% Cu, traces of Mg and Mn	Aircraft frames	Strong, light
Solder	60 to 70% Sn, 40 to 30% Pb	Joining metals together, electrical connections, low-friction bearings	Low melting point
Cupronickel	75% Cu, 25% Ni	'Silver' coins	Hard wearing, looks like silver, attractive
EPNS (electroplated nickel silver)	Cu, Ni, Ag	Plated onto cutlery, plates and bowls	Looks like silver, cheaper, resists corrosion
Alnico	Al, Ni, Co	Magnets	Aluminium is light, nickel and cobalt can be magnetised

2.1 QUESTIONS

Remembering

- State** whether the following are true or false.
 - Metal atoms pack tightly together, giving metals high density.
 - Free electrons in metals make the metals good conductors.
- List** the properties that all metals exhibit.
- List** four examples of each of the following, stating what they are used for:
 - metals that can be used in their pure form
 - alloys
- State** how many carats pure gold is.
- List** the different types of steel, in order from the lowest carbon content to the highest.

Understanding

- Define** the term:
 - base metal
 - alloy
- Alloys have advantages over their parent metals.* Use an example to **clarify** this statement.
- Outline** what the carat scale measures.
- Are coins pure metals or alloys? **Explain** your answer.
- Predict** whether metals would be good or poor electrical conductors if they had a tight hold on their outer-shell electrons.

Applying

- Identify** two properties of metals that make them ideal for electrical wiring.
- Identify** what feature in the photos in Figure 2.1.3 suggests that the steel bars of the barbecue conduct heat better than air.
- Identify** which metal:
 - is most abundant in Australian 'gold' and 'silver' coins
 - is the only metal that is a liquid at normal room temperature
 - is the main component of steel
 - is common to both the alloys brass and bronze
 - is added to iron to make stainless steel

Analysing

- Calculate** what fraction and percentage of pure gold is in:
 - a 12-carat gold ring
 - a 9-carat gold nose stud
 - a 22-carat gold chain **N**

Evaluating

- Propose** three reasons why mercury is ideal for thermometers.
- Use** the elements symbols in the periodic table to propose what the base metal in a ferrous alloy is likely to be.
- Aluminium is used for overhead electrical cables, while copper is used for home wiring. **Propose** a reason why.

Creating

- The table below shows the stress that different alloys of copper and zinc can take before breaking. **Construct** a graph of stress (vertical axis) against the percentage of copper (horizontal axis). **Analyse** your graph to answer the following questions. **N**
 - State** the breaking stress of: **N**
 - a 50/50 alloy of copper/zinc
 - an alloy of 20% Cu and 80% Zn
 - an alloy containing 60% zinc
 - pure copper
 - pure zinc
 - Identify** the proportions of copper that make the alloy stronger than pure copper.
 - Identify** the proportions of zinc that make it weaker than pure zinc.
 - Identify** the strongest copper/zinc alloy.
 - Identify** the composition of three alloys that all break at a strain of $25 \times 10^6 \text{ N/m}^2$.

% Cu	0	10	20	30	40	50	60	70	80	90	100
Stress ($\text{N/m}^2 \times 10^6$)	19	16	12	8	5	32	58	40	23	21	33

2.1 INVESTIGATING

Investigate your available resources (for example, textbooks, encyclopaedias, internet) to complete the following tasks.

- 1** Research why lead and mercury are referred to as cumulative poisons.
 - a** Explain what this means.
 - b** Identify what the main sources of these metals are.
 - c** Explain why schools generally use red alcohol thermometers and not mercury.
 - d** Summarise the main effects of these metals on the human body.
 - e** Research what happened in a Japanese village called Minamata and how it was connected with cumulative poisons.
- On the basis of your findings, construct a newspaper article or poster warning about cumulative poisons.

- 2** Find what dental fillings are made from, particularly what makes up dental amalgam.
 - a** Research why some dentists are concerned about using dental amalgam.
 - b** Outline some alternatives to using amalgam.

Present your research as a brochure to be left in the waiting rooms of dentists.
- 3 Investigate** the Bronze and Iron Ages. Propose ways in which the discovery of copper/bronze and iron/steel would have changed the way of life of people at that time.

Present your information in one of the following ways:

 - as an advertisement painted on the wall of a cave outlining the superior properties and uses of the new material
 - as a role-play where a salesperson is selling tools in the new materials 'cave-to-cave'
 - as a role-play with the 'inventor' of the new materials trying to convince the 'directors' of a primitive tool company to stop their old production lines and instead start production using the new materials.

2.1 PRACTICAL ACTIVITIES

1 Metallic crystals

Aim

To make crystals of silver

Equipment

- 250 mL glass beaker
- thick copper wire
- 0.1 M solution of silver nitrate (AgNO_3)
- spatula
- microscope slide
- microscope
- gloves
- safety glasses
- lab coat



Safety

The chemicals in this Prac are toxic and will stain so avoid contact with eyes, skin and mouth.

Method

- 1** Bend the copper wire into a loose coil that will fit inside the 250 mL beaker.
- 2** Place the copper wire coil into the beaker.
- 3** Add 200 mL of 0.1 M silver nitrate solution to the beaker.
- 4** Record your observations at the end of the lesson and at the beginning of the next lesson.
- 5** Dislodge the crystals from the wire and use the spatula to place some on to a microscope slide.
- 6** Use a microscope to examine the crystals more closely and draw a detailed picture of what you see.
- 7** Use the microscope to examine the copper wire.

>>

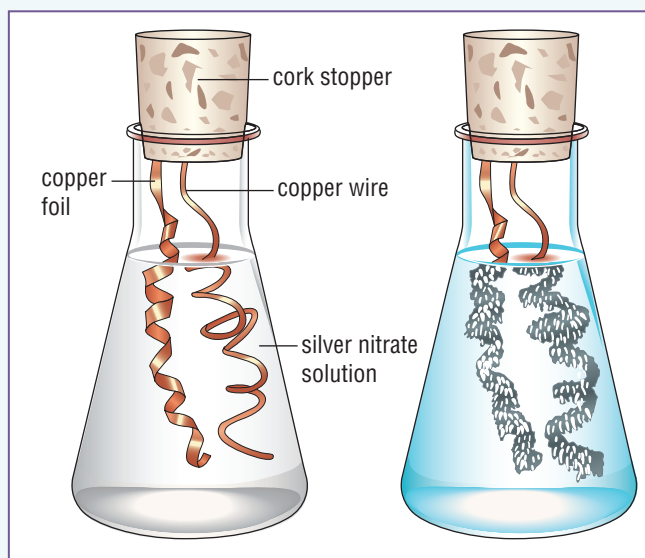

Fig 2.1.8

Questions

- 1 State** if the process you observed is a chemical or physical change and explain your answer.
- 2 Propose** where the silver crystals might have come from and suggest a word equation for this reaction.
- 3 Compare** the surface of the copper wire with a piece of copper wire that was not left in silver nitrate. **Explain** why they might look different.
- 4 Describe** any changes to the colour of the solution and **explain** why they might have occurred. Hint: **Investigate** what copper nitrate solution looks like. Your teacher may prepare a solution for you to observe.

2 How much is it worth?

Aim

To calculate the value of metal in Australian coins

Equipment

- \$2
- \$1
- 50-cent coin
- 20-cent coin
- 10 cent and 5 cent coins
- the business section from a recent newspaper (not Monday)
- access to an electronic scale

Method

- Find the following values and copy them into your workbook:
 - the US to Australian dollar exchange rate
 - the prices of aluminium, copper and nickel
- Convert any US dollar prices into Australian dollars by dividing by the exchange rate. For example, if $\text{A\$1} = \text{US\$0.5064}$ and the price of aluminium is $\text{US\$1408.50}$ per tonne, then its price in Australian dollars is $1408.50 \div 0.5064 = \text{A\$2781.40}$ per tonne.
- Convert any prices per tonne into prices per gram by dividing by 1 000 000. For example, if aluminium is $\text{A\$2781.40}$ per tonne, the price per gram is $2781.40 \times 1\,000\,000 = \text{A\$0.00278}$ or 0.278 cents per gram.
- Convert any prices per ounce into prices per gram by dividing by 28.35.

- Write a complete list of the prices in Australian dollars per gram.
- Use an electronic balance to find the masses of a \$1 and a \$2 coin.
- Copy and complete this calculation for each gold coin:
Mass of coin = _____ g

$$\begin{array}{r}
 \text{[put mass of coin here]} \\
 \downarrow \\
 \text{Mass of copper in coin} = 92\% \text{ of } \underline{\hspace{1cm}} = \underline{\hspace{1cm}} \text{ g} \\
 \text{Mass of aluminium in coin} = 6\% \text{ of } \underline{\hspace{1cm}} = \underline{\hspace{1cm}} \text{ g} \\
 \text{Mass of nickel in coin} = 2\% \text{ of } \underline{\hspace{1cm}} = \underline{\hspace{1cm}} \text{ g}
 \end{array}$$

$$\begin{array}{r}
 \text{[put mass of metals here]} \quad \text{[put price per gram here]} \\
 \downarrow \qquad \qquad \qquad \downarrow \\
 \text{Cost of copper} = \underline{\hspace{1cm}} \times \underline{\hspace{1cm}} = \text{A\$ } \underline{\hspace{1cm}} \\
 \text{Cost of aluminium} = \underline{\hspace{1cm}} \times \underline{\hspace{1cm}} = \text{A\$ } \underline{\hspace{1cm}} \\
 \text{Cost of nickel} = \underline{\hspace{1cm}} \times \underline{\hspace{1cm}} = \text{A\$ } \underline{\hspace{1cm}}
 \end{array}$$

- Add the answers to find the total cost of the coin.
- What percentage is this of its face value?
- Use a similar method to **calculate** the value of the silver coins.

Questions

- 1 Deduce** whether any of the coins are worth more than their face value.
- Fifty-cent coins originally had silver in them, but now don't. **Explain** why.
- Use the prices of gold and silver to **calculate** the cost of each coin if they were really gold or silver.

context

Some metals like gold and silver can be found in their pure state. Most metals, however, are found as compounds and need to be 'released' from the oxygen they are bonded to before they can be used. As new extraction technologies developed, new metals such as bronze,

iron and aluminium were discovered. Each newly extracted metal allowed technology to change. Society changed with them. The reserves of metal ores are, however, limited and so scientists must find ways to conserve them while also protecting our planet's fragile ecology.

Metals in the crust

Metals make up only a quarter of the Earth's crust. Oxygen and silicon make up the rest. The oxygen does not exist as a gas, but is chemically combined with metal atoms as solid **oxides** or with silicon to form sand.

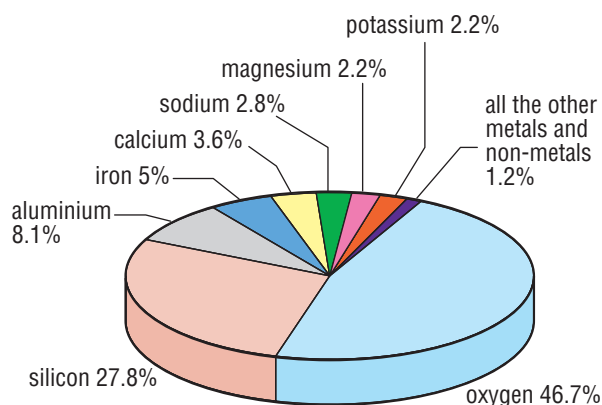

Fig 2.2.1 The pie chart shows the percentage of elements in the Earth's crust. Oxygen is by far the most abundant, followed by silicon and then aluminium. Many commonly used metals are so scarce that they don't even appear on the pie chart.

Pure metals in nature

Some metals can be found as pure elements in nature as either a **nugget** or a **vein** of the metal trapped in another rock such as quartz. These elements are known as **native** elements and include elements such as gold (element symbol Au), silver (Ag) and copper (Cu) and much rarer elements such as cadmium (Cd). Native elements are able to occur in nature because they are very **stable** and **unreactive**. This means the elements survive for millennia without reacting with the chemicals of the air, dirt or water.



Fig 2.2.2 Underground mining is particularly dangerous with miners regularly descending two kilometres below the surface. The deepest mine in the world is a gold mine in South Africa that goes to an incredible depth of 3.5 kilometres!

Science Clip

There's gold in them thar' hills

The earliest recorded discovery of gold in Australia was in 1823 at Bathurst, New South Wales by James McBrien, a Department of Lands surveyor. The first gold rush had begun! Today, gold is still mined at many sites in New South Wales including Adelong, Hill End and Tomingley.

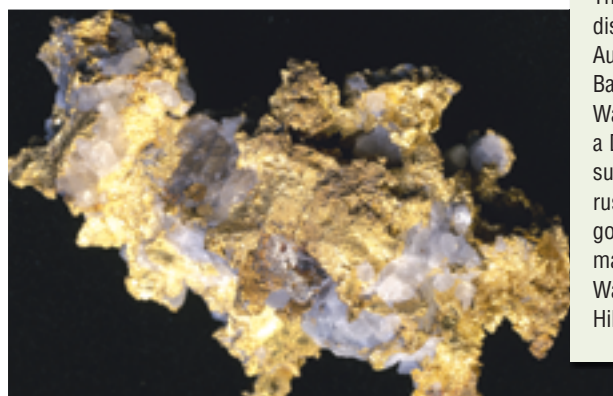

Fig 2.2.3 A vein of pure gold trapped in quartz



Metals in minerals and ores

Metals not found naturally in their pure form are combined with other elements. **Minerals** are rocks containing large amounts of a particular metal. If there is sufficient metal to make it worth mining, it is called an **ore**. The table on page 45 shows the chemical composition of some ores and the metals that can be extracted from them.

Is it worth mining?

Mining produces valuable metals and creates jobs. Sometimes, however, mining is not worth its expense or the negative effects on society and the environment.

Before mining begins, many important questions need to be asked in order to assess the advantages and disadvantages.

- How much ore is there and how concentrated is it?
- How deep is the ore? What type of mine is needed?
- Is the site close to existing ports and rail lines?
- Is there a population centre nearby from which workers can be employed?
- Who owns or controls the land?
- What water and air pollution will it cause?
- Do any endangered plants or animals live in that area?
- What damage will be done to the environment and how can it be minimised?
- What will be the cost of building the mine and the processing plants, and repairing the environmental damage?
- What profit is expected?

Fig 2.2.4 Major ore deposits in Australia

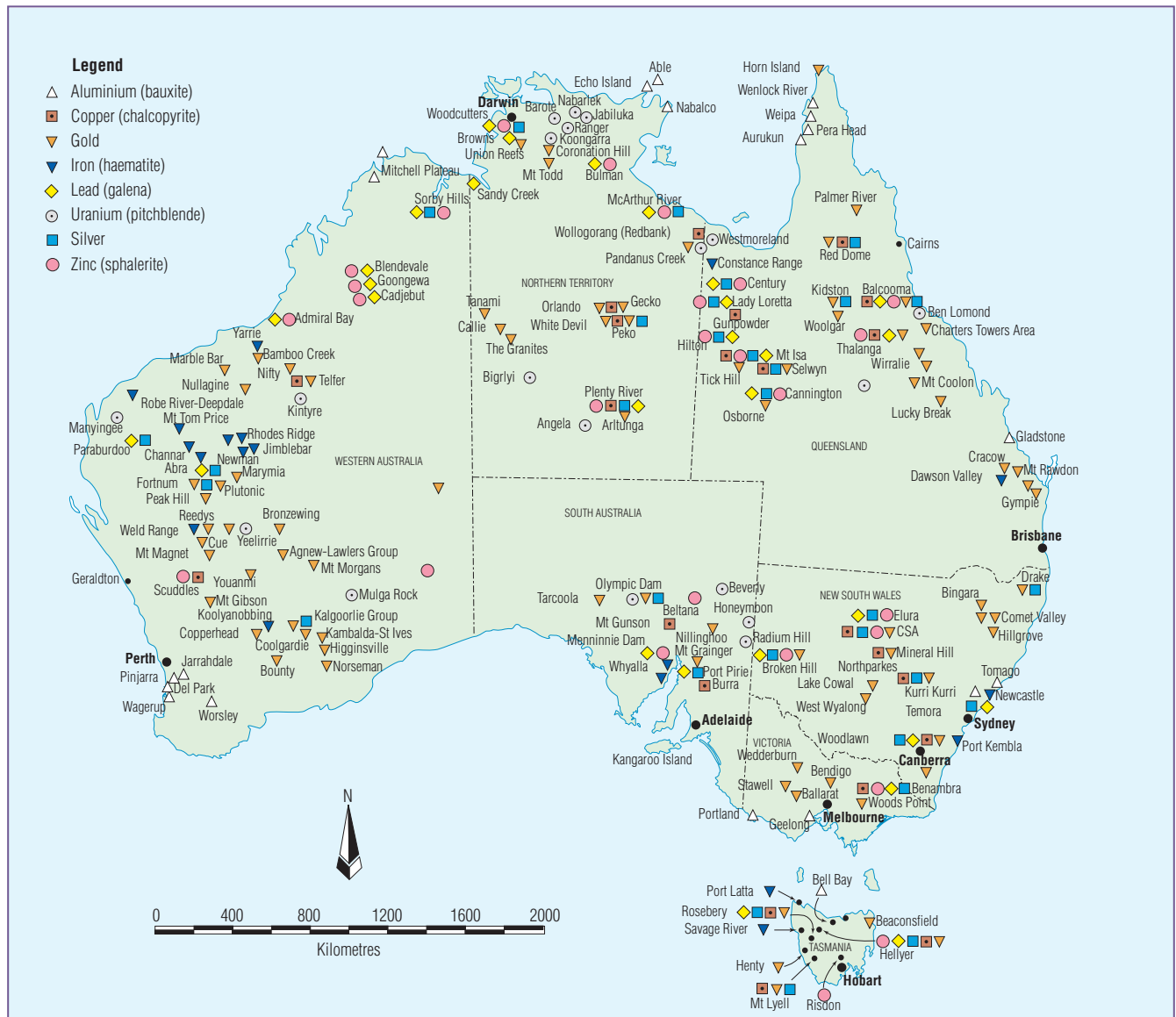

Ore	Chemical composition	Metal extracted
Bauxite	Aluminium oxide, Al_2O_3	Aluminium, Al
Chalcopyrite	Copper iron sulfide, $CuFeS_2$	Copper, Cu
Galena	Lead sulfide, PbS	Lead, Pb
Haematite	Iron oxide, Fe_2O_3	Iron, Fe
Pitchblende	Uranium oxide, U_3O_8	Uranium, U
Rutile	Titanium oxide, TiO_2	Titanium, Ti
Sphalerite	Zinc sulfide, ZnS	Zinc, Zn

The mining process

Underground mines are used for the mining of deep ores but water penetration, possible collapse, venting of poisonous and explosive gases and the provision of fresh air for the miners are problems that must be managed.

If the ore is close to the surface, **open-cut mining** is easier. An **overburden** of soil is removed and the ore is dredged out, creating **benches**, or steps that spiral into the hole.

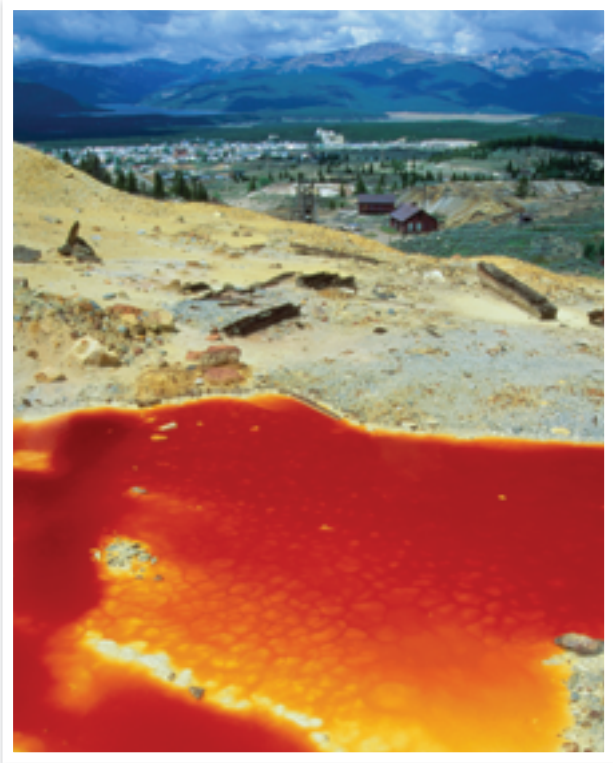

Fig 2.2.5 Pollution and environmental degradation can be severe around mines and processing sites, often leaving **slag** (hills of rubble) and polluted lakes behind.

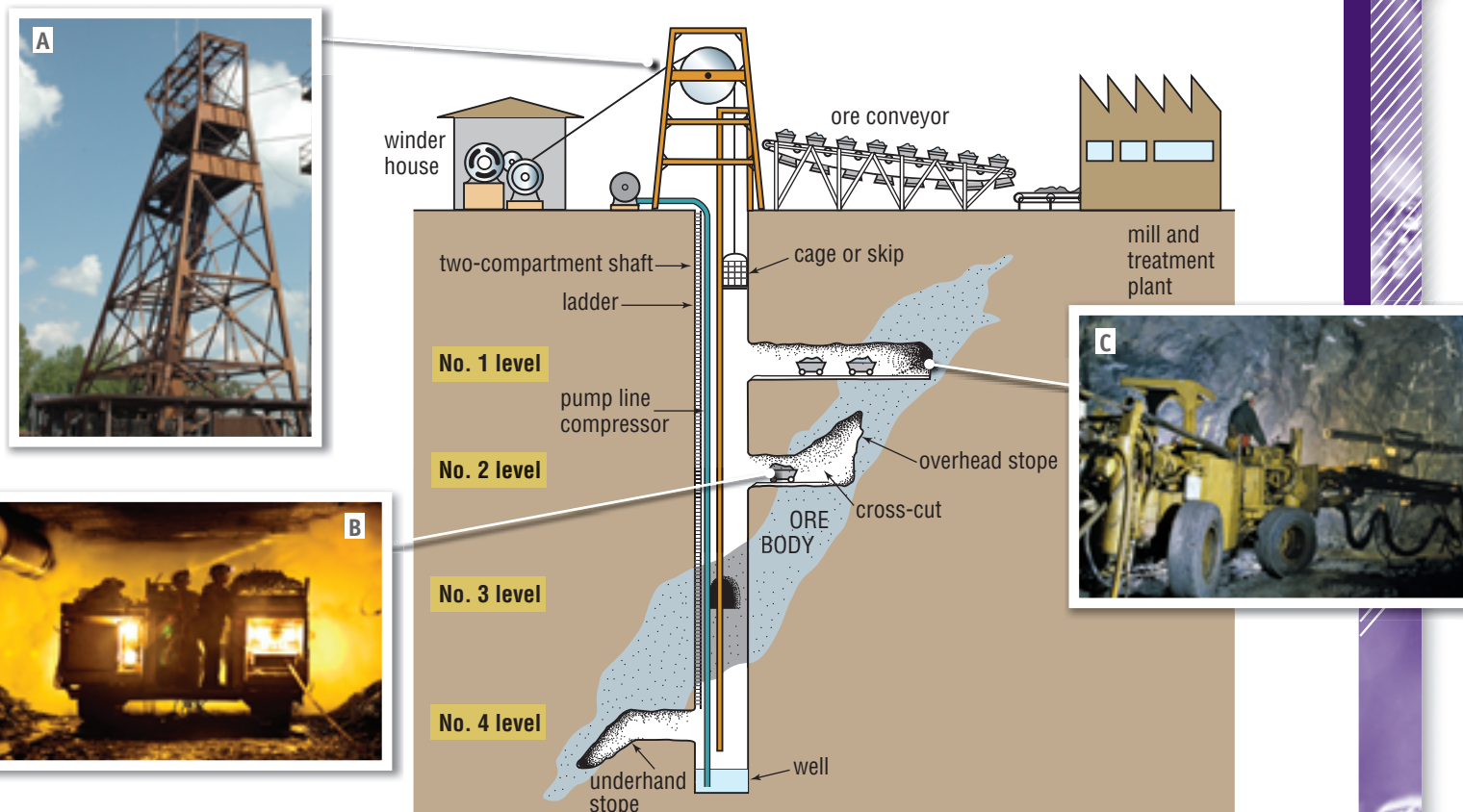

Fig 2.2.6 The structure of an underground mine: **A** Mine headframe (these are sometimes also underground); **B** Coal miners in mine shaft; **C** Mechanised mining.

These are also used as access roads to haul the ore to the surface by truck. Open-cut mines cause problems including pollution of surrounding areas with dust, pooling of water, destruction of land above the ore, and the need to repair the land after mining ceases.

Mining has a huge impact on the environment but is necessary for society as a whole. Realising this, governments now require mining companies to ‘clean up after themselves’. This means mining companies must now factor in the cost of rehabilitating and revegetating the land that they have mined. In the case of open-cut mines, the soil must be replaced; trees must be replanted and waterways must be stabilised once the mine is no longer profitable.



Fig 2.2.7 An open-cut mine showing benches

Concentration of the ore

Impurities and waste called **gangue** are mined with the ore. The mined material is crushed by rollers or by large steel balls that fill a large rotating drum called a **ball mill**. Gravity and sieves separate some of the gangue, with the remainder then separated by **froth-flotation**. This is a technique pioneered in Broken Hill, New South Wales, in which the crushed ore floats away on a frothy emulsion of oil and water, leaving the gangue behind. The ore is now ready for **extraction**—the release of the pure metal from the ore.



Extraction methods

Different metals require different methods of extraction. This is determined largely by how chemically reactive the metal is. Metals that are highly chemically reactive such as sodium (Na) or potassium (K) tend to be most stable when they are combined with other elements. Therefore it takes a lot of energy to separate them from these elements into their pure form. As a result, these metals need to be extracted by a powerful technique known as **electrolysis**. Less reactive metals like iron (Fe) or tin (Sn) are often found combined with oxygen, sulfur or carbonates. However, because these metals are more stable, they can be extracted more easily by heating or by removing the non-metals. Some metals, such as gold (Au) are so unreactive that they exist in nature naturally with no extraction necessary.

Extraction by electrolysis

Electrolysis is such a powerful method that it can extract any metal from its ore. It uses a huge amount of electricity, however, and is used only when there is no cheaper method available. For example, sodium (Na), potassium (K) and aluminium (Al) are so reactive that they can only be extracted in this way.

A voltage is applied to a molten sample or solution of the ore and the positive metal ions move to the negative electrode. When they get there, the ions are forced to take back the outer-shell electrons to form metal atoms that then plate the electrode. Sodium is extracted by electrolysis of seawater or, more commonly, rock salt. The salt is melted to break the salt crystals into its ions, then converted into pure elements by electrolysis.

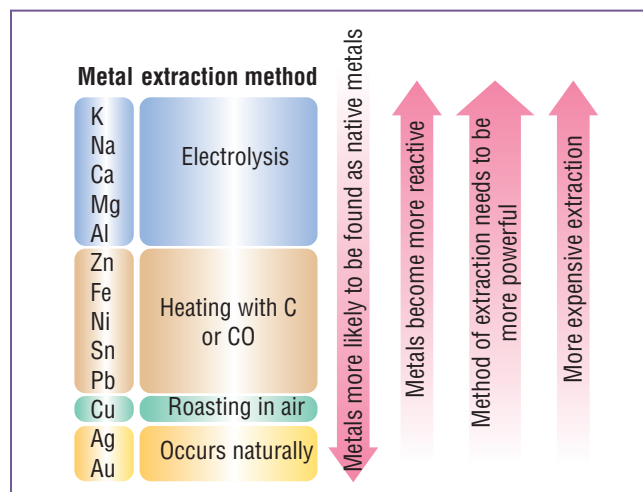

Fig 2.2.8 Different metals require different methods of extraction. Native metals only need a little cleaning up while reactive metals like sodium and aluminium need electrolysis, the most expensive and most powerful extraction method.

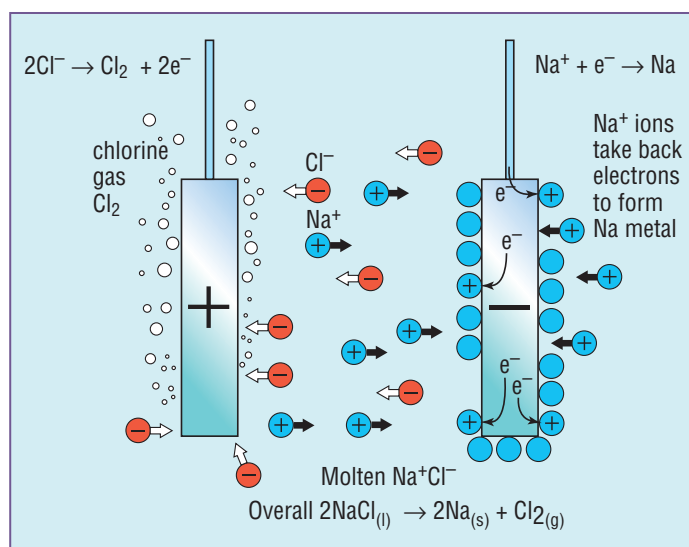

Fig 2.2.9 The reaction of sodium from molten rock salt by electrolysis

Extraction by heat

Heat is sometimes sufficient to extract the pure metal. This is called **smelting**. Stable metals can be extracted by simply heating in air where the ore reacts with the oxygen. For example, copper is extracted by roasting copper(I) sulfide, found in an ore called copper pyrites:



The more reactive metals such as lead, iron and zinc need carbon or carbon monoxide (CO) to help the conversion along. To extract iron, coke (a source of carbon), limestone (CaCO_3) and iron ore (Fe_2O_3) are heated in a **blast furnace**. The coke and limestone help to produce carbon monoxide (CO). This reacts with the iron ore to form molten iron, which then runs to the bottom of the furnace:

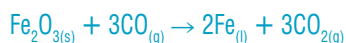

Science Clip

Aluminium, more valuable than gold

Aluminium cookware is reported to have originated when the French Emperor Napoleon III served the King of Siam (modern-day Thailand) at a state banquet in 1867. The plates and cutlery used were made of aluminium, with less important guests eating from plates of pure gold. Aluminium was so hard to extract that it was very, very expensive at the time.

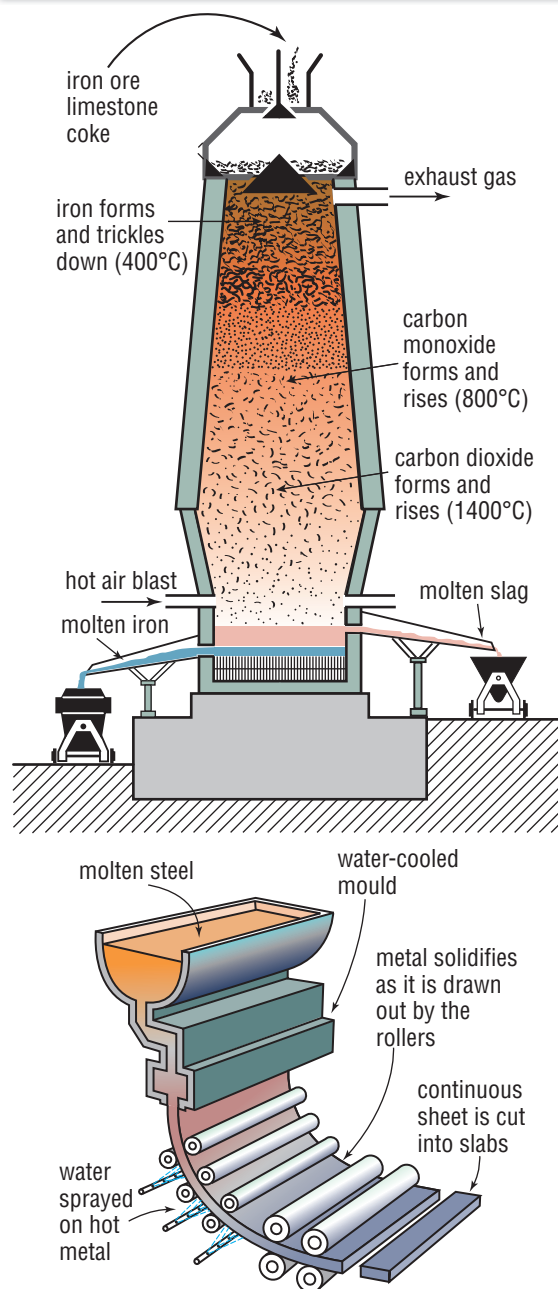

Fig 2.2.10 Smelting iron in a blast furnace and rolling it into shape

Recycling versus mining

Metals are **non-renewable resources** and all will eventually run out so it is important to find ways to use and reuse metal responsibly. Metals that make up less than 0.1 per cent of the Earth's crust are considered to be scarce. Silver (abundance 0.000 01 per cent) and gold (0.000 000 5 per cent) are scarce and therefore expensive, but some of our most commonly used metals are considered scarce too: copper (0.007 per cent), mercury (0.000 05 per cent), zinc (0.013 per cent), lead (0.0016 per cent) and tin (0.004 per cent).

Luckily, iron is relatively common, since iron consumption is currently nine times that of all the other metals put together. The table indicates when known reserves of some metals are estimated to run out.

Metal	Element symbol	Amount used per year (millions of tonnes)	Estimated year at which known reserves of the metal will run out
Iron	Fe	800	2110
Aluminium	Al	12	2350
Copper	Cu	8	2040
Zinc	Zn	4.5	2060
Lead	Pb	4	2020
Tin	Sn	0.25	2015

Recycling is one way that you can help conserve the Earth's limited metal resources. However, not all metals can be recycled. Recycling of aluminium is common, because the production cost of new aluminium is 20 times more than the cost of recycling it.

Recycling of many metals is often too expensive to make it worthwhile. The difficulty of separating the iron from tin in food cans makes it far too expensive to recycle iron at the moment, despite millions of cans being thrown out every year.

 **Worksheet 2.3** Extraction of metals

 **Worksheet 2.4** Media analysis 2



Fig 2.2.11 It is cheaper to recycle than to produce new aluminium. For this reason, more than 50 per cent of all aluminium cans in Australia are collected and reprocessed.

Science Clip

Eating gold

In many cultures, it has been traditional to decorate food with pieces of gold leaf (fine layers of hammered gold). Many of Australia's top restaurants are now using it too, on top of dishes such as risotto and even in cocktails. The gold leaf is eaten but has no taste, smell or texture. Injections of gold have been used for many years as relief from arthritis, so maybe this helps justify the cost of eating it!

Science Fact File

An extraterrestrial native

Only a small amount of native iron exists on Earth and it's extraterrestrial! Iron reacts readily with oxygen in the atmosphere and so any iron on Earth rusted away to become iron ore long ago. Most of the native iron found on Earth comes from iron-nickel meteorites that hit the planet a relatively short time ago. Up to that time, they were in space, preserved by the lack of oxygen.

Science Clip

The human cost of mining

Mining has always been a very dangerous occupation with Australia's worst mining disaster in history occurring in a coal mine near Mount Kembla in New South Wales in 1902. An explosion in the mine killed 96 men and boys while at work or in the course of trying to save the lives of others. A service of commemoration is still held each 31 July at the Mt Kembla Soldiers' and Miners' Memorial Church. A spectacular story of survival came out of Tasmania in 2006. A minor earthquake caused a shaft of the Beaconsfield gold mine to collapse, killing Larry Knight and trapping his co-workers Todd Russell and Brant Webb within their protective cage. They survived for two weeks on ground water and a single muesli bar until they were released!

2.2 QUESTIONS

Remembering

- Name** the form in which oxygen is usually found in the Earth's crust.
- List** the most common elements in the Earth's crust starting with the most common.
- List** three ores and the main metal they contain.
- Name:**
 - metal that can be extracted by roasting in air
 - two native metals
 - three metals that can only be extracted by electrolysis
 - four metals extracted using a blast furnace
- List** the problems of an underground mine.
- Recall** the smelting of iron ore by writing balanced chemical equations for the five main steps.
- State** one disadvantage and one advantage of recycling metals.
- State** whether the following statements are true or false.
 - Metals are known as renewable resources.
 - Iron is the most common metal in the Earth's crust.
 - Metals that make up less than 0.1% of the Earth's crust are scarce.
- Name** one metal that:
 - is currently cheaper to recycle than mine and extract
 - is currently cheaper to mine and extract than recycle

Understanding

- Outline** possible reasons why:
 - mining company might decide not to mine a particular metal at a particular site
 - a mine is commercially successful
- Define** the terms:
 - smelting
 - non-renewable resource
- Explain** a disadvantage of using electrolysis for extraction of metals.

Applying

- Use** the map in Figure 2.2.4 to list three sites where each of the major ores listed in the table on page 45 are mined.
- Use** a labelled diagram to show:
 - the structure of an underground mine
 - the extraction of sodium from sodium chloride by electrolysis
 - the structure of a blast furnace

- From the following list of words, **identify** the correct terms to fill in the spaces below:

extraction gangue crushed
froth flotation ball mill

Mined material is _____ by rollers or steel balls within a _____. Impurities known as _____ are separated by _____. The remaining ore is now ready for _____.

- For the extraction of sodium, **identify**:

- the raw material
- the ion that migrates towards each electrode
- the overall chemical equation for its extraction
- the other product that is made

- Complete the flow chart in Figure 2.2.12 by **identifying** the correct words to **explain** the process of mining an ore and extracting the metal it contains:

exploration native-metal
electrolysis roasting slag
gangue blast furnace
froth flotation open-cut
crushing underground

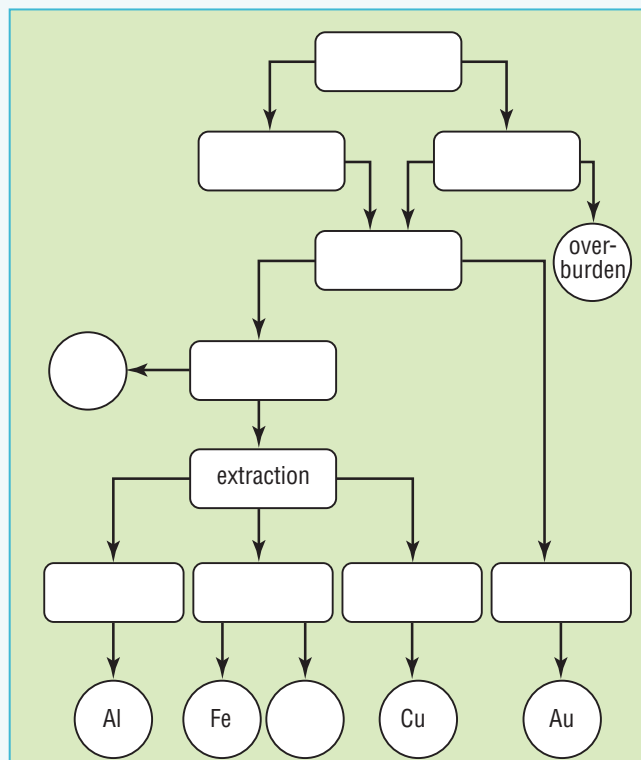

Fig 2.2.12



Analysing

- 18 a** **Research** and **record** the number of cans and types of cans your household throws out in a week. **N**
- b** Estimate how many cans are thrown out per year.
- 19** **Contrast** the following terms:
- a** mineral and ore
 - b** shaft, drive and stope
 - c** slag and gangue
 - d** overburden and ore

Evaluating

- 20** Mining companies regularly take out mining leases on any land that may contain valuable mineral ores. This may even include the land on which you live. If the mining company holds the lease, it has the legal right to buy the land. Do you consider this acceptable? **Justify** your answer.
- 21** Platinum is a native element. **Propose** where it should appear in Figure 2.2.8.

Creating

- 22 a** A rich gold deposit has been discovered 100 metres under Richville, a very wealthy suburb in your area. A multinational mining company is deciding whether it should mine there. **Construct** two letters or emails to a newspaper—one supporting a mine and one against.
- b** Imagine that the gold deposit had been discovered instead in a remote area of the outback inhabited by its traditional indigenous owners. **Assess** what you should do now.
- 23** **Construct** a bar graph showing the elemental composition of the Earth's crust. **N**
- 24** **Construct** a map of Australia indicating where major ores listed in the table on page 45 are mined.
- 25** The years for the first successful extraction of different metals are shown in the table. **Construct** a timeline showing these discoveries. **N**

Metal	Date
Aluminium	1890 CE
Zinc	1500 CE
Iron	1400 BCE
Lead	2000 BCE
Copper	8000 BCE

2.2 INVESTIGATING

Investigate your available resources (for example, textbooks, encyclopaedias, internet) to complete the following tasks.

- 1** Compare the current buy-back price of aluminium cans with the price for new aluminium by researching commodity prices in newspapers. **N**
- 2** Research how car bodies can be recycled for their metals. How do the useful metals get separated from non-recyclable materials? Construct a flow chart displaying the recycling process.
- 3** Find out how to pan for gold. Design an instruction sheet showing how to do it.
- 4** Locate a current mining town in Australia.
 - a** Describe the ore mined there.
 - b** Use a map to summarise where it is processed and extracted.
 - c** Describe the transport facilities that probably had to be built to mine and shift the ore, giving consideration to whether it is near a large town.
- 5** Research older techniques used in underground mines such as the use of canaries, the Davy lamp and the methods used for digging rock before the invention of the pneumatic drill. Construct a poster showing how mining used to take place.
- 6** Research a particular mine disaster, constructing a timeline of events.
- 7** Find what metals are used in making mobile phones and their batteries and the difficulties they produce if not recycled responsibly. Construct a brochure that could be used to inform the public. **L**

e-xploring

To experience the challenges metallurgists face, a list of web destinations can be found on **Science Focus 4 Second Edition Student Lounge**. Click on 'Orsome froth' to apply your skills and scientific knowledge to virtually operate a mineral processing plant.



2.2 PRACTICAL ACTIVITIES

1 Chocolate chip mining



Aim

To compare the amount of 'valuable' material mined with the waste produced.

Equipment

- chocolate-chip cookies
- access to electronic scales
- access to a range of laboratory and non-laboratory equipment such as sieves
- beakers
- measuring cylinders etc.

Method

- 1 Collect a chocolate-chip cookie. The cookie represents a sample of ore that contains chips of an extremely valuable mineral called chocolate.
- 2 In groups, check the equipment available to you and then **design** your own method to efficiently extract the chocolate chips from the waste material (the rest of the cookie).
- 3 Write the method in your workbook.
- 4 In your workbooks, construct a table similar to that shown below.
- 5 Measure the mass of the chocolate-chip cookie. Enter your measurement in the table.
- 6 In groups, develop a method for measuring or estimating the volume of a cookie in cm^3 or mL. Enter the volume in the table.
- 7 After the extraction, measure the mass and volume of both the extracted chocolate chips and the waste material.
- 8 Refine your technique, improving it where necessary.
- 9 If time and cookies allow, try your new technique.
- 10 Collect the results from at least two other groups and enter their data into the table.

Questions

- 1 **Compare** the mass of each group's cookie and the masses of the chocolate chips extracted.
- 2 **State** whether the composition of each sample of ore (each cookie) was the same.
- 3 **Compare** the volume of the waste material after extraction with the volume of the cookie at the start.
- 4 **Predict** whether the waste material after extraction would fill the hole left when the cookie was originally 'dug up'.
- 5 In this Prac, **identify** what represented the:
 - a ore
 - b mineral
 - c gangue

Mass of cookie (g)	Volume of cookie (mL or cm^3)	Mass of chocolate chips after extraction (g)	Volume of chocolate chips after extraction (g)	Mass of waste material (g)	Volume of waste material (g)

>>

2 Froth flotation

Aim

To use froth to separate out a solid

Equipment

- mixture of sand and iron filings (1 part filings to 5 parts sand)
- large test tube
- water
- rubber stopper to fit test tube
- kerosene
- detergent

Method

- 1 Add a spatula full of sand/iron filings to the test tube.
- 2 Add about 4 cm of water and place the rubber stopper in the top of the test tube.
- 3 Shake the test tube to mix the contents as best you can.
- 4 Add 2 cm of kerosene and 5 drops of detergent to the test tube and replace the stopper. Shake the test tube for several seconds, then observe its contents.
- 5 Attempt to recover some of the iron filings.

Questions

- 1 The kerosene coats the iron filings, making them water repellent. **Propose** what the detergent does in this process.
- 2 In the actual froth flotation process, the ore must be crushed very finely. **Propose** reasons why.

3 Extracting copper by electrolysis

Aim

To extract solid copper from a solution

Equipment

- 1 M sulfuric acid
- black copper oxide
- spatula
- 50 mL beaker
- glass stirring rod
- Bunsen burner
- tripod
- gauze mat
- bench mat and matches
- 12 V power pack
- globe
- electrodes and connecting leads
- filter paper/paper towel

Method

- 1 Pour approximately 20 mL of 1M sulfuric acid into the beaker.
- 2 Add a small spatula of black copper oxide.
- 3 Carefully warm over a yellow Bunsen burner flame. Stir with the glass rod until all the copper oxide is dissolved and the solution is blue. Do not boil.
- 4 Remove the beaker from the tripod and place on the bench mat.
- 5 Connect up the circuit as shown in Figure 2.2.13. Set the power pack on 6 V DC and allow it to run for a couple of minutes.
- 6 Draw a diagram of the set-up. Mark the electrode being copper plated. What is happening at the other electrode and to the colour of the solution?

- Turn off the power and remove the electrodes. Carefully remove any pure copper onto filter paper/paper towel.

Questions

- Explain** whether copper formed at the positive or negative electrode.
- Explain** what happened to the blue colour of the solution.
- In this experiment, copper ions in the solution are taking back electrons to form copper atoms. **Describe** the evidence for this.
- Construct** a balanced chemical equation for what is happening to the copper ions.
- Propose** a reason why electrolysis is never used commercially to produce copper.

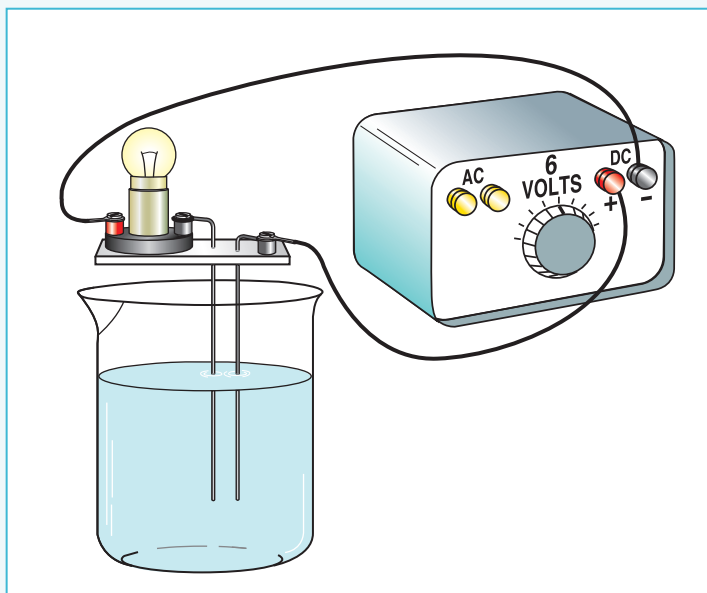

Fig 2.2.13

4 Extracting copper by roasting

Aim

To extract solid copper from copper(I) oxide by roasting

Equipment

- crucible with cover
- ring stand
- clay triangle
- Bunsen burner
- spatula
- filter paper
- watch glass
- balance
- tongs
- 3 g copper(II) oxide (CuO)
- 3 g charcoal

Method

- Measure 3 g of copper(II) oxide onto a piece of filter paper.
- Measure out 3 g of charcoal on a second piece of filter paper.
- Transfer both chemicals into the crucible.
- Mix the two chemicals in the crucible with the spatula.

- Place the cover on the crucible, and set it in the clay triangle on the ring stand.
- Heat strongly for 10–15 minutes.
- Turn off the burner and allow the crucible to cool for 10 minutes.
- Use tongs to carefully remove the crucible cover. (Caution: it may still be hot!)
- Dump the contents of the crucible onto the watch-glass.
- Use the lab scoop to spread out the mixture. Look for copper—you can recognise it by its distinctive red-orange metallic color.

Questions

- Describe** your observations and construct a word equation for this reaction.
- Investigate** how copper is mined, extracted and processed. Identify which step in the process is most similar to the reaction you observed in this experiment. **Identify** what the next step in the process would be toward extracting usable copper metal.
- Research** and **list** all the ores of copper.

context

Before 1950 plastics were almost unheard of and people only used natural materials such as wool, cotton or paper.



Fig 2.3.1 Plastics are everywhere. Most packaging, toys and fibres are made from some form of plastic.

Plastic: carbon-based compounds

Carbon is a Group IV element and each carbon atom can bond with up to four other atoms. This gives carbon the ability to form continuous lattices (such as those found in diamond and graphite) and an amazing variety of molecules. Most molecules found in living organisms—fossil fuels, drugs, plastics and fibres contain atoms of carbon. This puts them into the same category—they are all **organic compounds**.

Plastics are synthetic carbon-based compounds with unique properties that make them extremely useful for a wide variety of applications.

Plastics:

- are good thermal and electrical insulators—they are molecules and so have no free electrons to conduct electricity or heat
- are strong and light and often flexible
- can be moulded into different shapes
- can have other chemicals added to colour and reinforce them (e.g. glass fibres are added to a plastic resin to make fibreglass)
- are not **biodegradable**—they do not react with water or oxygen, making them weather- and rot-resistant.

These days, plastics are everywhere. Like the metals that came before them, plastics have changed technology and the way we build and use our world. Despite their usefulness, plastics have also created the problems of contamination and pollution of the environment and the harming of wildlife.

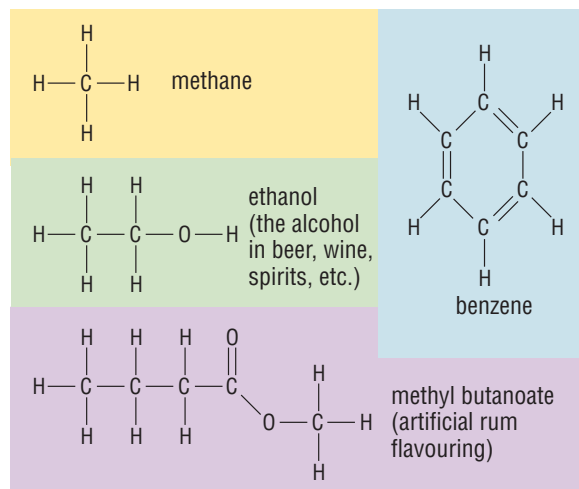

Fig 2.3.2 Organic molecules are the basis of life and much of our everyday chemistry. Organic molecules always have a 'backbone' made of carbon.

This is both a good and a bad property—outdoor furniture will not rot, but plastic packaging won't decompose when thrown out.

Apart from being non-biodegradable, plastics have other properties that limit their usefulness or make them potentially dangerous.

- Plastics become brittle over time if exposed to sunlight. This often causes the dashboards in cars to crack after many years of being parked in the sun. Sometimes chemicals can be added or rubbed into them to retain their flexibility and to lengthen their useful life.
- Plastics sometimes react with or dissolve in other organic substances (such as turpentine, methylated spirits, petrol).
- Plastics can sometimes burn very easily, producing noxious fumes when they do (such as PVC produces hydrochloric acid fumes when it burns).

The following table shows some examples of the many ways plastic is used today.



Plastic	Uses
Polythene (polyethene)	Milk crates, rubbish bins, buckets, plastic bags, cling wrap, soft squeeze bottles
Acrylic	Safety glasses, plastic screens
PVC (Polyvinyl chloride), polychloroethene	Waterproof clothing, guttering, pipes
Nylon	Brush bristles, fabrics, rope, carpets
Polystyrene	Without bubbles (unexpanded): yoghurt and margarine containers; with bubbles (expanded): insulation, portable coolers like Eskies, cups, packaging
Melamine	Unbreakable dishes, surfaces for cupboards and shelves
Urea formaldehyde	Electric switches and plugs
Phenol formaldehyde	Door handles, saucepan handles



Science Clip

Noxious aircraft!

Plastics and synthetic fibres are used in the interiors of aircraft because they are light and can be moulded into the shapes required. The toxic fumes and smoke they produce on burning have been the primary cause of death in otherwise survivable accidents. Fifty-five people were asphyxiated aboard a British Airtours Boeing 737 at Manchester, UK in 1985 when the plane caught fire while still on the ground. A fire started in a luggage compartment of a Saudi Arabian Airlines Lockheed Tristar soon after take-off from Riyadh in 1980, filling the cabin with toxic smoke. The plane returned to the airport and landed safely. Instead of evacuating as quickly as possible, the captain taxied and then ran the engines for a total of six minutes. All 301 people on board died, including the captain.



Fig 2.3.3 Plastics are not biodegradable and so will not break down when thrown away. This pollutes the environment for many generations and becomes a danger for wildlife.

Science Clip

Elephants on the billiard table!

By 1868, elephants had been slaughtered in such huge numbers that the supply of ivory could not meet demand. The Phelan and Collender Company offered a US\$10 000 award to anyone who could find a replacement for the ivory used in their production of billiard balls. In response, brothers John and Isaiah Hyatt developed a natural polymer, celluloid nitrate or celluloid for the billiard balls. It was also used as photographic film and for dolls and false teeth. This latter use was worrying since celluloid is highly flammable!



Fig 2.3.4 The Airbus 380 is the largest passenger aircraft ever produced, carrying up to 555 people over two decks. Roughly 22 per cent of the aircraft is made from an advanced lightweight plastic-composite material called CFRP.

Monomers and polymers

Plastics are classified as **polymers** and start as small molecules derived from the oil industry. Polymers contain a very long molecule made up of a chain of small, identical molecules called **monomers**. A process called **polymerisation** then combines these smaller molecules into the larger one that make up plastic. The small molecules are called monomers and the big ones polymers. *Poly* is a Greek word that means ‘many’. Polyurethane is made from many urethane molecules, and polyethene is ‘many ethenes’. Imagine a monomer as a single ‘paperclip’. The polymer ‘polypaperclip’ would be a string of connected paperclips.

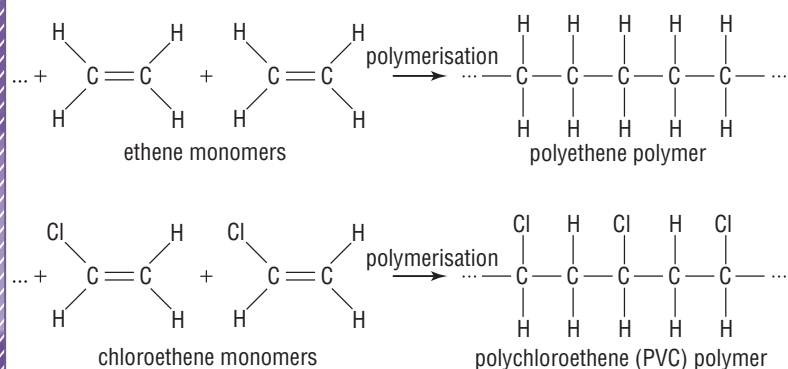

Fig 2.3.5 Many identical monomers join to make a polymer.

Heating plastics

For some applications, it is preferable to use plastics that can be melted and remoulded. For other applications, the plastics should be hard and heat resistant. It is possible to control the way plastics react to heat by changing how the polymer chains are linked together. This determines whether a plastic is a **thermosetting plastic** or a **thermoplastic**.

Thermosetting plastics

Thermosetting plastics cannot be remoulded. The long polymer chains are also linked to each other (known as **cross-linking**), locking them into a giant, grid-like molecular structure. Individual strands cannot be shifted without breaking part of the structure. This makes thermosetting plastics hard (scratch resistant), brittle (will shatter if dropped) and rigid (not able to be bent).

When heated, individual strands cannot move—thermosetting plastics will **char** (burn at the edges) but will not soften. They therefore need to be manufactured and moulded at the same time. Bakelite is an example of a thermosetting plastic.

Thermoplastics

Other plastics simply melt when heated and reset when cooled. These materials are known as thermoplastic—examples are PVC, polythene and acrylic. In thermoplastics, the long polymer chains arrange themselves parallel to each other, allowing them to slide over each other and giving them flexibility and stretch. If heated, they retain their basic structure but become liquid and can slip over each other to fill whatever moulds they are poured into. Thermoplastics are manufactured as powder, pellets or granules for shipping to other factories to be heated and moulded.

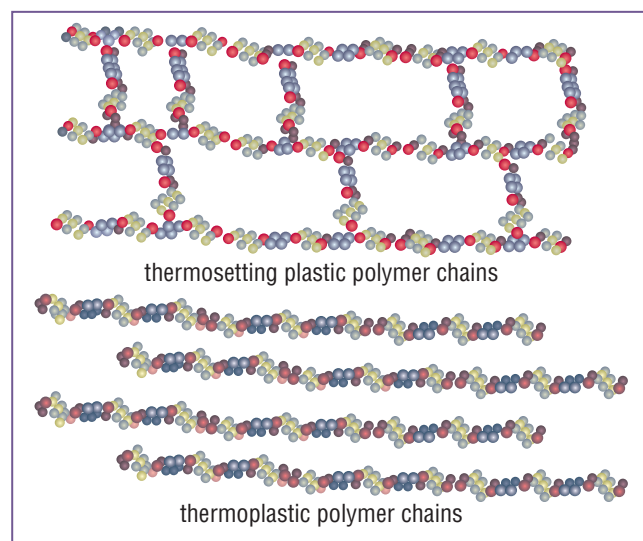

Fig 2.3.6 The polymer chains in a thermosetting plastic are bound together by other molecules—this is known as cross-linking. When heated, these cross-links are broken, destroying the plastic. The molecules in thermoplastics are not cross-linked which allows the molecules to move around when heated. This allows thermoplastics to melt and take on new shapes.

Science Fact File

It's only natural!

Many natural polymers also exist. Wood is made from the organic polymers of cellulose, lignin and resin. Natural rubber, amber, gum, asphalt and pitch are all natural organic polymers. Asbestos is an example of an inorganic polymer that contains no carbon.

Working with plastic

Thermoplastics can be moulded into new shapes in a number of different ways.

Extrusion moulding

A nozzle creates the shape in **extrusion moulding**. Extrusion moulding is used to make many common items such as pipes, hoses, plastic straws, curtain tracks, rods and fibres.

a Extrusion moulding: the nozzle creates the shape

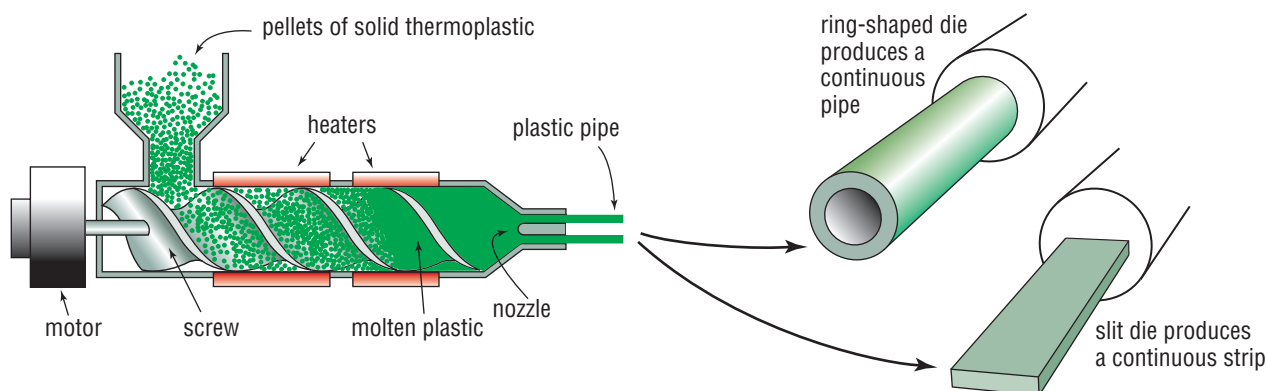

b Blow moulding: molten plastic is expanded by compressed air to fill the mould

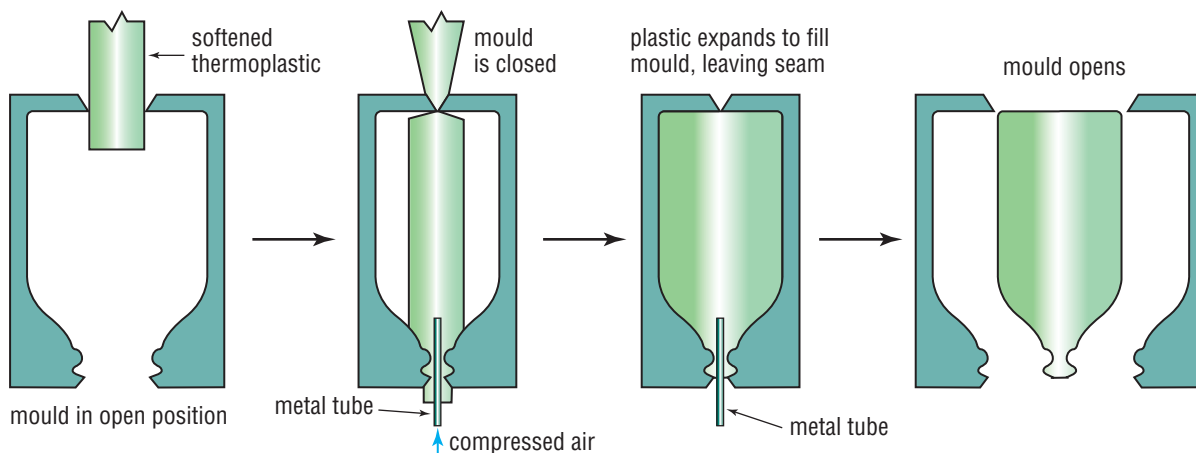

c Injection moulding: molten plastic is squeezed into a two-part mould to fill it

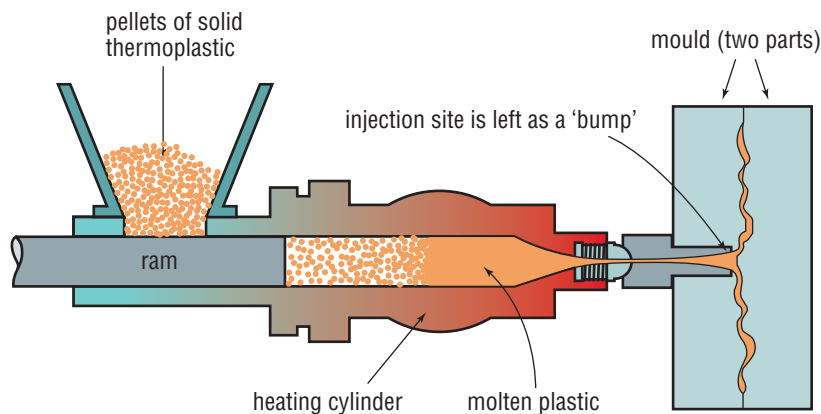

Fig 2.3.7 Thermoplastics can be moulded using three different techniques.

Blow moulding

Bottles are commonly made by **blow moulding**. A tell-tale sign of blow moulding is the seam where the two halves of the mould meet.

Injection moulding

In **injection moulding**, molten plastic is squeezed into a two-part mould to fill it. This is the most common method of production. A knob of plastic is left behind where the plastic injection took place. The method is commonly used to produce toys, bottle caps and outdoor furniture.

Science
Clip**The first use of thermoplastic resins?**

Australian Aboriginal people have been using **resins** for thousands of years. Resins from certain plants become soft when heated and very hard when cooled—because they are thermoplastic. Resins are obtained from both Porcupine Grass (*Triodia* species) and Grass Trees (*Xanthorrhoea* species). If a fire goes through an area of grass trees, the resin oozes out and forms bubbles in the sand around the base of the tree. The resin is collected and crushed to a powder. The end of a spear can be dabbed in the crushed resin, and heated until the resin becomes sticky. This is repeated many times until there is enough resin to adhere a spearhead. The soft resin can also be used to attach stone blades to the wooden handles of tools or weapons using a process called 'hafting'.



Fig 2.3.8 Resin has been added to the hooked end of this spear thrower and is being heated to make it sticky.

Recycling plastics

Thermoplastics are recyclable as they can be re-melted and re-moulded many times. Recycling is an important way of managing plastics as it keeps them out of the environment. Plastics are not biodegradable so they stay in tips and the environment for hundreds, even thousands, of years. Plastic bags are a major concern for birds, animals and sea life. These creatures can become tangled in them or try to feed on them, with the bag subsequently blocking the animal's digestive tract. Because plastic bags do not decay, they are released once more into the environment when the animal's carcass decays.

Worksheet 2.5 Recycling

Science
Clip**Bugs inspire the first synthetic plastic!**

Shellac is a common natural furniture varnish and wax, and is made from the excretions of tiny *Tachardia lacca* bugs. In 1907, Belgian chemist Leo Baekeland was working in the United States to make an artificial substitute for it. His equipment became clogged when he mixed phenol and formaldehyde. The new material could not be dissolved and was a superb thermal and electrical insulator. He had invented the plastic, bakelite, and it found immediate and widespread use as electrical fittings and saucepan handles.

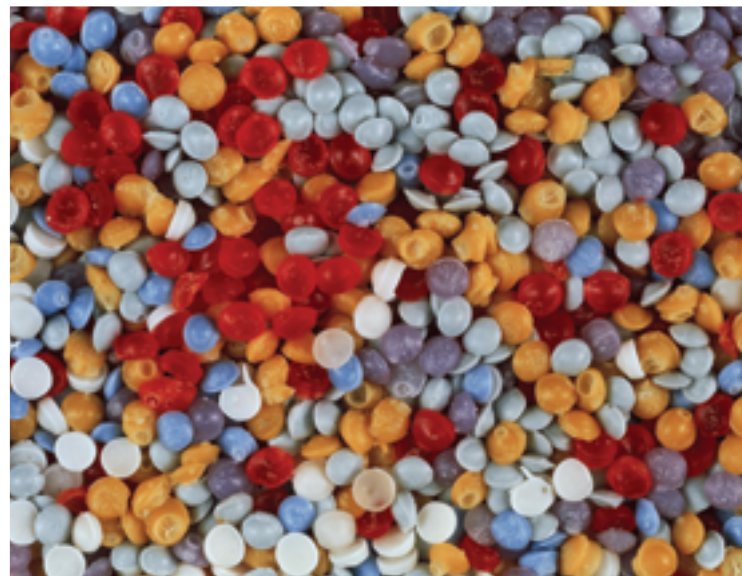

Fig 2.3.9 Scientists are working to make cheap, biodegradable plastics. Some shops are already using biodegradable plastic bags although they are more expensive than the ones that are non-biodegradable. These thermoplastic pellets are made from plants instead of oil and so are biodegradable.

2.3 QUESTIONS

Remembering

- 1 **a State** the group number for carbon (C).
- b State** the maximum number of bonds it can form.
- c Name** two continuous lattices that it forms.
- d Name** two examples of molecules containing carbon.
- 2 **List** three examples of an organic compound.
- 3 **List** examples of:
 - a five synthetic polymers
 - b three natural polymers
 - c one inorganic polymer
- 4 **List** three ways in which thermoplastics are manufactured.
- 5 **List** three examples of plastic items that are commonly made by injection moulding.
- 6 **State** the type of moulding that is used to make bottles.
- 7 **List** three properties of plastics made by thermosetting.

Understanding

- 8 **Outline** three desirable and three undesirable properties of plastics.
- 9 **Explain** how thermoplastics can melt and then reset on cooling.
- 10 **Explain** how cross-links stop thermosetting plastics from melting.

Applying

- 11 **Use** a periodic table to determine these facts about carbon (C):
 - a its atomic number
 - b its period
 - c the number of electrons in its outer shell.
- 12 **Identify** the correct terms in the following list to fill in the spaces below.
 polymer, polymerisation, monomer, plastics
 A small molecule capable of joining together in a long chain is called a _____. When small molecules join together they form a _____. Small molecules join together in a process known as _____ and result in the production of _____.
- 13 A train could be considered a polymer. **Identify** what the monomer would be.
- 14 **Use** a diagram to demonstrate how extrusion moulding is achieved.

Analysing

- 15 **Contrast** a monomer with a polymer.
- 16 **Compare** thermoplastics and thermosetting plastics by listing their similarities and differences.
- 17 Inspect 10 plastic items around your school or home for seams or 'bumps'. You might start with your plastic pen or drink bottle. **Classify** each item as being made by extrusion, blow or injection moulding.

Evaluating

- 18 Would the production of thermosetting plastic powder be a good idea? **Justify** your answer.
- 19 **Evaluate** the use of plastics in terms of their effect on society and the environment.
- 20 **Propose** other uses for plastic bags other than just throwing them away.
- 21 **Propose** what effect the phasing out of plastic bags in supermarkets will have on our everyday lives.
- 22 The labels of some fabrics insist that no heat be applied to them, from ironing or tumble-drying. **Propose** reasons why.

Creating

- 23 **Use** a paperclip to represent a monomer. Link them together to **construct** models of a:
 - a polymer
 - b thermoplastic
 - c thermosetting plastic.
- 24 **a Investigate** how many plastic bags are collected in one week in your home from shopping.
 - b **Discuss** your results and include comments on whether alternatives could have been used.
- 25 **Design** a survey to poll the recycling habits of Australian households.
 - a As a class, compile a survey and use the survey to poll each household.
 - b Plot the results or display them on a poster.
- 26 **Design** an advertising campaign to encourage people to recycle plastics. Present your campaign idea in the form of a poster. 

2.3 INVESTIGATING

Investigate your available resources (for example, textbooks, encyclopaedias, internet) to research materials such as polystyrene which are technically referred to as foams. Find how plastic foams are made. In your answer, include the chemical equations involved.

e-xploring



To find out more about how plastics are recycled, a list of web destinations can be found on **Science Focus 4 Second Edition Student Lounge**.

- Construct a graph showing the amount of plastic used in Australia in each state. Produce a report which outlines how plastics are recycled. **N**
- Justify the need to recycle plastics.

2.3 PRACTICAL ACTIVITIES

1 Identifying plastics

Aim

To identify properties of some common plastics

Equipment

- labelled pieces of polythene (each about 2×1 cm)
- polystyrene
- PVC
- Perspex
- nylon
- 'mystery' plastics
- dissection board/bench mat
- scissors
- turpentine
- nail-polish remover
- dilute hydrochloric acid (HCl)
- detergent
- 250 mL beaker
- tongs
- access to meths burner set-up in fume hood



Safety

WARNING: The meths burner must be in a fume hood. If no fume hood is available, do not do any burning tests. Do not smell any fumes or smoke.

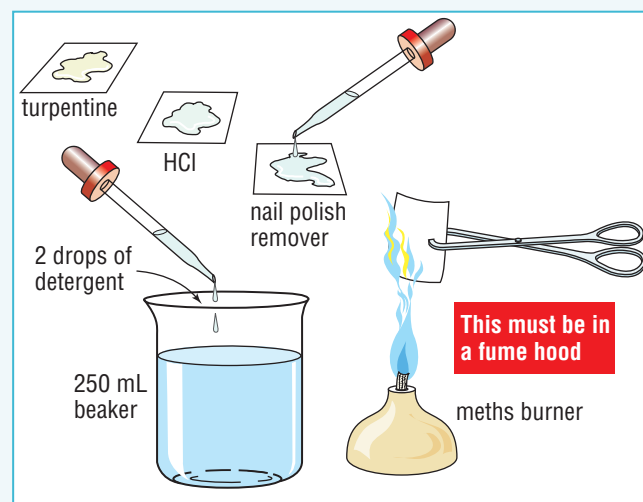

Fig 2.3.10

Method

- 1 Copy the table on page 61 into your workbook. Your teacher may split you into groups to run all tests on one plastic only or to run one test on all the plastics.
- 2 Describe the appearance—is it transparent, translucent or opaque?
- 3 Describe its flexibility—did it bend or was it stiff?
- 4 Did it feel 'waxy'?
- 5 Did your fingernail or the scissors scratch it?
- 6 How hard was it to cut with scissors?
- 7 Are the cut edges smooth or jagged? Did the cut show bubbles or cells?
- 8 Add two drops of detergent to a 250 mL beaker of cold water. Add a plastic—does it float or sink?

	Polythene	Polystyrene foam	PVC	Perspex	Nylon
Appearance					
Flexibility					
Feel					
Ease of scratching					
Ease of cutting					
Description of cut					
Does it float?					
Effect of flame					
What dissolves it?					

- 9 Place a drop each of turpentine, HCl and nail-polish remover onto three small squares of each plastic. Leave for five minutes and record whether each piece dissolved, went soft or remained hard.
- 10 Break each plastic into smaller pieces and use tongs to hold a piece in a meths burner flame.
- 11 Did the burning produce smoke? If so, what colour was the smoke? What colour was the flame? Did molten plastic drop from it? Did the drops burn as they fell?
- 12 Run tests to determine what each of the mystery plastics is.

Questions

- 1 **Identify** each plastic as either thermoplastic or thermosetting.
- 2 **Identify** the mystery plastics.
- 3 **Explain** why the burning must be done in the fume hood and not in the lab.
- 4 **Explain** what is produced from PVC when it is burnt.
- 5 **Deduce** whether any plastics sink in or react with water.
- 6 A sample of plastic kept burning once it was lit. Its flame was blue with a yellow tip. **Identify** the plastic.

2 Making casein plastic

Aim

To make a polymer called casein from milk. Casein was an early plastic that is still used for buttons and some wood glues. It is hardened industrially with formalin.

Equipment

- full cream milk
- vinegar
- Bunsen burner
- bench mat
- tripod
- gauze mat and matches
- 100 mL measuring cylinder
- two 250 mL beakers
- thermometer
- glass stirring rod
- elastic band
- coarse cloth for straining
- paper towel/filter paper
- assorted moulds (bottle caps, moulded chocolate trays etc.)
- fine sandpaper
- tongs

Method

- 1 Set up the Bunsen burner and tripod.
- 2 Place 100 mL of milk in one of the 250 mL beakers. Warm gently until it reaches 50°C. Do not overheat.
- 3 Add 10 mL vinegar and stir with the stirring rod.
- 4 The milk should curdle to form white lumps of curds (casein) and yellowish liquid called whey.
- 5 Use the elastic band to secure the piece of cloth tightly over the other 250 mL beaker. Strain through the curds and whey.
- 6 Carefully remove the cloth and squeeze to remove as much liquid as you can.
- 7 Empty onto the paper towel/filter paper. Pat dry, then firmly press into moulds. Leave the casein to dry in the sun.
- 8 After a couple of days, remove the mould and polish with the sandpaper.
- 9 Use tongs to hold a small amount of the dry casein in a Bunsen flame. Does it melt, burn or char?

>>

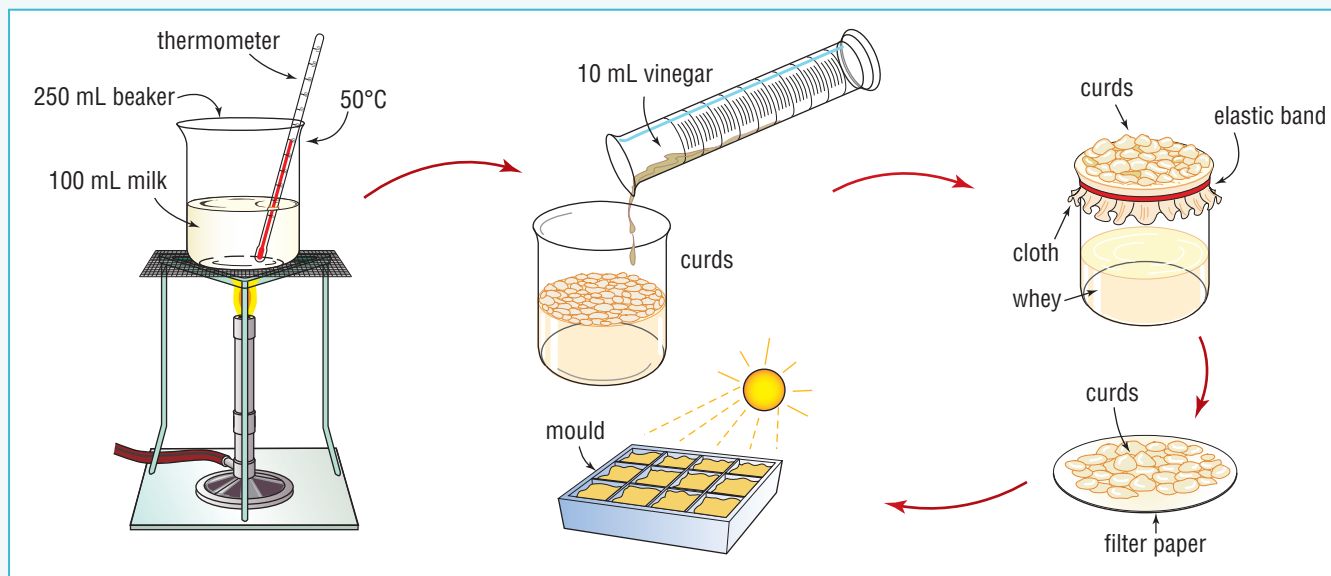

Fig 2.3.11

Extension

- 10 Chip off a piece of casein and find its mass.
- 11 For every 50 g of casein you chip off, measure out 20 g of borax and 40 mL of water.
- 12 Add the borax and water to a conical flask and swirl until dissolved.
- 13 Crumble the casein into the borax solution and shake until creamy glue is formed.
- 14 Use it to glue two chips of wood together. Use the clamp or elastic bands to hold the pieces together. Leave it overnight to 'cure', then try to separate the pieces of wood.

Questions

- 1 **Deduce** whether the casein plastic produced was thermosetting or thermoplastic.
- 2 **State** the purpose of the final test.
- 3 **Identify** a use of the casein.
- 4 **Outline** how casein is hardened industrially.
- 5 Little Miss Muffet ate her curds and whey. **Explain** whether you would.

context

The chemical composition of a material is not the only thing that gives a material its useful properties. The way the material is processed and shaped is also important. A solid piece of glass, for example, is useful for making windows. Glass can also be processed into a tangled nest of long thin strands

to be used as fire resistant insulation or glued together with a resin to make surfboards. Many other materials are processed into long thin strands to give them special properties. These strands are referred to as fibres.

Natural and synthetic fibres

A **fibre** is any solid formed into a hair-like strand. Fibres can be lumped into balls like cotton buds, bundled together into threads or rope or woven to make sheets of fabric. Fibres can be used individually, like when a spider hangs from a single strand of gossamer. There are two main types of fibres—natural and synthetic.

Synthetic fibres

Synthetic fibres are made entirely from chemicals and are usually stronger than natural fibres. Nylon, terylene, lycra, spandex, elastane, polyesters and acrylics are all synthetic fibres.

Synthetic fibres are produced by pushing a liquid polymer through tiny holes where it solidifies on the other side, forming a long, continuous fibre. This process is known as **extrusion**. Some use natural fibres as their building block. Wood and paper (a wood product) contain the natural polymer cellulose. If wood pulp is soaked in solutions of caustic soda (sodium hydroxide, NaOH) a sticky cellulose gum forms. When extruded, the gum forms a new fibre—viscose, acetate, tri-acetate and rayon all come from wood pulp.

Drip-dry or **wash-and-wear** fabrics are synthetic. However, synthetics are uncomfortable in hot weather because they do not absorb sweat. Instead, the moisture stays on our skin, making us wet and clammy.



Fig 2.4.1 Fibres are the strands that are woven together to make fabrics. This scanning electron microscope (SEM) image is of georgette crepe, a fabric woven from synthetic fibres.

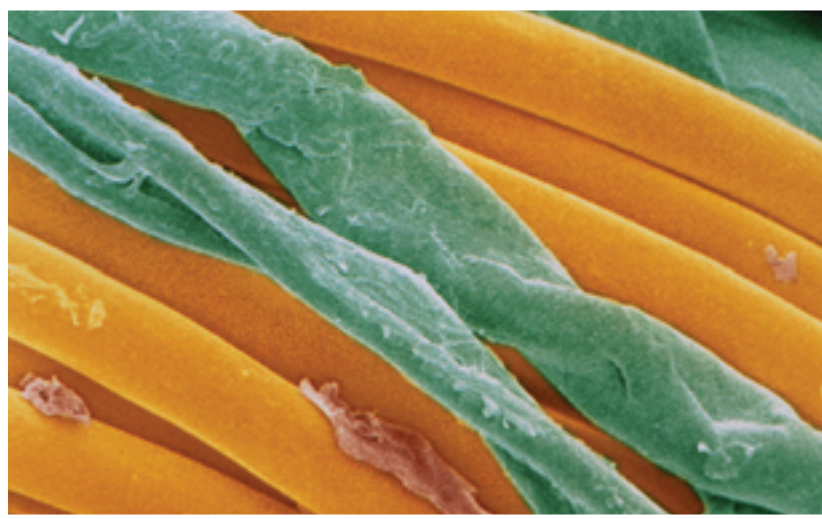

Fig 2.4.2 The surfaces of synthetic fibres are far smoother than natural fibres. This also makes them far more water-resistant. The rough (green) fibre here is the natural fibre cotton. The smoother orange fibres are synthetic polyester fibres.





Science Clip

Fibres for fun!

Fibres were not just used as serious tools in Aboriginal life, they were used for fun! String games were common in indigenous cultures both in Australia and around the world. In these games, string figure designs were made that resembled objects used in everyday life, such as dilly bags and baskets. Designs also showed animals and people, or ideas such as the forces of nature. String games were used for learning and to help tell stories.

Fig 2.4.3 Aboriginal women show children how to make a turtle shape with string.



Fig 2.4.4 An Aboriginal woman using natural fibres to make a basket.

Science Clip

Gut the cat

The strings in the bows of string instruments such as violins and cellos were originally made from fibres obtained from cats. Likewise, Aboriginal people sometimes stripped the tendons from animals such as kangaroos they had killed for food. These were then used when strong bindings were required.

Natural fibres

Wool, mohair, silk, cotton, linen (flax), hair, fur and coir (the hairy covering of a coconut) are all **natural fibres**. They have had many uses for thousands of years. The fibres are particularly useful in the production of fabrics for use in clothing, sheets etc. Natural fibres have rough surfaces which trap air. This makes them an excellent insulator, stopping heat loss from your body in winter. Their rough surfaces also provide a large surface area to absorb water and sweat, making cotton, linen and wool clothes more comfortable in hot, humid weather than their synthetic equivalents. Although natural fibres have lots of benefits, they tend to be more expensive because it takes more time and effort to produce them.

Natural plant fibres have long been used in many traditional Aboriginal communities to make objects needed for hunting as well as for carrying and collecting food and for ritual objects used in religious ceremonies. Natural plant fibres were used for string, bags, rope, fishing nets or baskets, clothing and mats. More recently, these natural fibres have been used to make baskets and objects that are created solely for their artistic value.

Fibres commonly come from the following plant parts:

- underground stems (**rhizomes**) of plants such as the bulrush
- leaves and stems of grass-like plants such as the mat-rush
- bark of trees and shrubs such as some species of Acacia and native hibiscus.

The gathered plant material is soaked in water to rot away useless material. The fibres are then stripped away by scraping with a sharp rock or shell, or by chewing. On some trees, such as the paperbark, little preparation is needed. The bark is simply peeled from the trees.



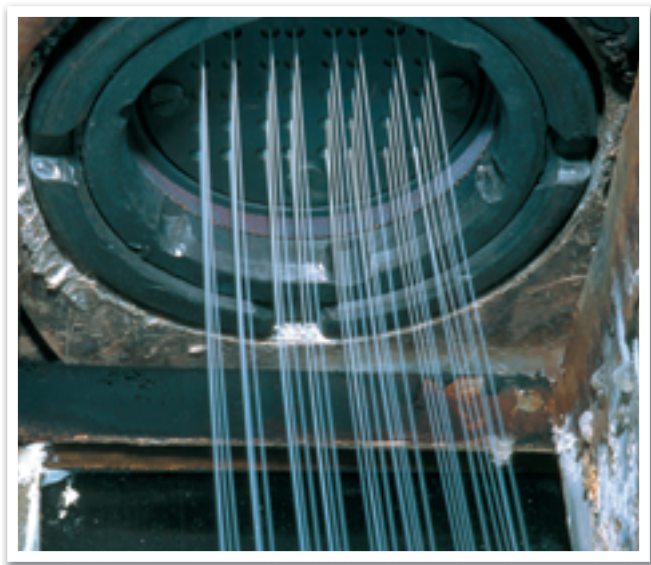

Fig 2.4.5 Softened thermoplastic is squeezed out of a multi-holed nozzle called a spinneret. A synthetic fibre is formed. However, the fibre will melt if heated, so clothes made from these fibres must be ironed with care and tumble-drying is usually not recommended.

Length and strength

The molecules in a synthetic fibre are aligned along the thread, making them stronger than the plastics they came from. The fibre will be particularly strong if its molecules are long—the longer the molecule, the greater its attraction to others that lie next to it, and the stronger it will be. The fibre can still tear though as the end of each molecule represents a weak spot.

Monofilaments are made from molecules that are the same length as the fibre. There are no ends and therefore no weak spots. Fishing lines are monofilaments of nylon. Monofilament materials are extremely strong and flexible, making them ideal for uses where a tear or puncture would be catastrophic.

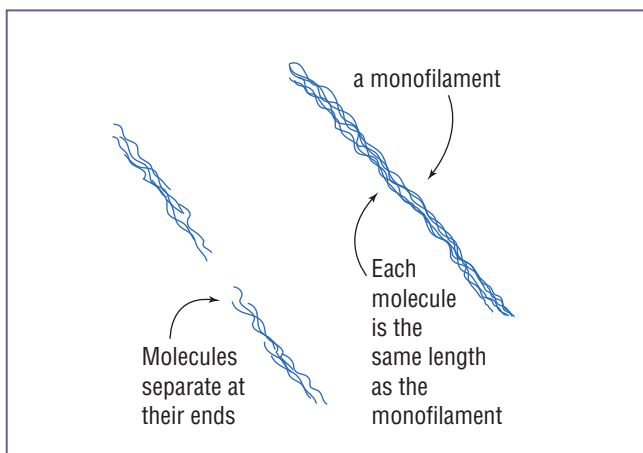

Fig 2.4.6 Longer molecules produce stronger fibres than shorter ones. The strongest are monofilaments.

Kevlar is a monofilament that is five times stronger than steel, but half the density of fibreglass. It is used in bulletproof vests, the sails of ocean-going yachts and the fuel tanks (or fuel-bags) of Formula 1 racing cars. Ropes, fibre-optic cables, automotive hoses, belts and gaskets are often made of Kevlar. Goalie masks used in hockey are made of a fibreglass/Kevlar mix.

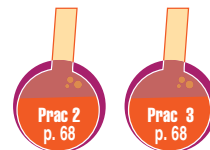

Fig 2.4.7 Monofilaments are the basis of protective sport masks. Monofilaments are unbroken fibres which are particularly strong.

Science Clip

New, improved Concorde

In 2000, an Air France Concorde took off from Charles De Gaulle Airport in Paris. A tyre burst, sending fragments into the wing, puncturing the fuel tanks. The spilled fuel ignited and that was the end for the plane. Concorde's once again took to the sky in 2001, this time with fuel tanks lined with Kevlar. However, they never regained the patronage they had before the catastrophe and were finally removed from service in 2003.

Other fibres

If synthetic fibres are heated strongly with no air present, they do not burn but char until all that is left is a fibre of pure carbon. **Carbon fibre** is extremely strong and when mixed with resins can be used for making lightweight and flexible structures ideal for bike frames and tennis racquets.

Science Clip

Swimming in shoes!

The first swimsuits were made of wool which holds water and gets very heavy. This made swimming difficult and drowning easy. In the 1930s Jantzen's 'Topper' swimwear allowed men to zip off their tops. The bikini was launched in 1952, but the newly developed 'lastex' fabric needed bone or metal stiffeners to prevent it slipping off! Modern swimwear is commonly made from nylon, elastane or lycra blends. Today, swimmers are once again also wearing neck-to-knee bathers, to protect them from UV radiation and to allow competitive swimmers to reduce drag. Adidas makes a competitive full body swimsuit made from teflon-coated lycra, while Speedo makes suits from 'Fastskin', which has a texture modelled on shark skin.



Fig 2.4.8 Synthetic fibres are mostly used for today's swimwear as they do not hold water like natural fibres.

Glass fibre is produced by running molten glass into a perforated steel bowl (like the barrel of a washing machine). When spun fast, glass threads fly out and then cool in the air. When mixed with resins, **fibreglass** is produced.

Science Clip

Worms—lots of them!

Silk is a natural fibre made from the cocoons of silkworms. It takes one tonne of mulberry leaves to feed 20 000 silkworms, yet together, they will produce less than 4 kg of silk.



Fig 2.4.9 A silkworm creates its silky cocoon in preparation for metamorphosis into a moth.

2.4 QUESTIONS

Remembering

- State** whether the following are true or false.
 - A fibre is any substance that can be woven or knitted into a fabric.
 - Nylon, cotton and linen are all examples of natural fibres.
 - Natural fibres are produced using a spinneret.
- List** three examples each of:
 - natural fibres
 - synthetic fibres made from plastics
 - synthetic fibres made from wood products
 - fibres used traditionally by Aboriginal people
 - objects made from Kevlar
- Name** the 'nozzle' used to form synthetic fibres.

Understanding

- Explain** why natural fibres are not drip-dry, tending instead to hold any water in them.
- Explain** why fishing lines are so strong, especially given how thin they are.
- Outline** what is meant by a monofilament.
- Explain** how the length of a molecule affects the strength of a fibre.
- If a monofilament fibre is 1 metre long, **predict** how long the polymer molecules are that make it up.
- Briefly **outline** how fibreglass is produced.

Applying

- Identify** two examples of where fibres are used:
 - in the home
 - by animals in nature

- 11 a Identify** three applications of glass fibres.
- b** Explain how the properties of glass fibres make them useful in these applications.
- 12 a Identify** a material other than glass that can be found as both a fibre and in some other form.
- b Explain** how the properties of the two forms are different.
- c Demonstrate** these differences by how the two forms of the material are used.
- 13 Identify** what is strange about the production of carbon fibres.

Analysing

- 14 Contrast** the following properties of natural and synthetic fibres:
- their insulating properties
 - their ability to absorb water
 - their surfaces
- 15** If the monomer unit of a synthetic polymer fibre is 10 nm long ($\frac{1}{1\,000\,000\,000}$ th of a metre), **calculate** how many monomer units are in an unbroken 1 metre long monofilament.

Evaluating

- 16 Propose** reasons why care must be taken when drying and pressing synthetic fibres.

2.4 INVESTIGATING

Investigate your available resources (for example, textbooks, encyclopaedias, internet) to complete the following tasks.

- Research how spiders use and produce gossamer.
 - Find what other insects produce silks.
 - Create a flow chart showing how a natural (e.g. cotton, silk) or synthetic fibre (nylon, polyester) is produced into clothing.
- Investigate** the polymer used to make the monofilament Kelvar. Draw one monomer unit of the Kelvar polymer.

2.4 PRACTICAL ACTIVITIES

1 Making nylon: teacher demonstration

Aim

To make a sample of nylon



Safety

This demonstration must be done in a fume hood.

Equipment

- fume hood
- 1,6-diaminohexane
- anhydrous sodium carbonate
- sebacoyl chloride or adipoyl chloride
- cyclohexane
- two 250 mL beakers
- tweezers
- glass stirring rod

Method

- Dissolve 2.2 g of 1,6-diaminohexane and 5 g of anhydrous sodium carbonate in 50 mL of water.
- In another beaker, mix 2 mL of sebacoyl chloride or adipoyl chloride in 50 mL of cyclohexane.
- Gently pour the 1,6-diaminohexane solution down the side of the beaker and onto the top of the cyclohexane solution. The two solutions must not mix but must form layers.
- Use tweezers to lift part of the layer of nylon formed between the solutions. Drape it over the glass stirring rod and wind the fibre out.

Questions

- Construct** a three-frame cartoon or diagram to show how the nylon was made.
- Predict** what would have formed if the two solutions had been allowed to mix.
- The nylon fibre formed is not very useful. **Explain** why.

2 Identifying fibres

Aim

To compare and contrast natural and synthetic fibres

Equipment

- labelled samples of fabrics (wool, cotton, linen, rayon, nylon, polyester)
- microscope
- microscope slide and coverslip
- pins or tweezers
- metal tongs
- matches
- bench mat

Method

- 1 Remove an individual thread, about 2 cm long, from each fabric sample.
- 2 Place it on the microscope slide and use the tweezers or pins to tease the fibres apart.
- 3 Place a coverslip on top and inspect the fibres under the microscope.
- 4 In your workbook, sketch and label each fibre, taking note of its surface.
- 5 Cut or tear a strip about 2×1 cm from each fabric.

- 6 Use tongs to hold a strip over the bench mat. Hold a lit match under the strip. Record your observations for each fabric. Did it catch fire, melt or char? What colour were the flame and smoke? What was left?

Questions

- 1 Match your samples with the diagrams in Figure 2.4.10.
- 2 **Deduce** which fibres were natural and which were synthetic.
- 3 **Explain** why synthetic fibres have smoother surfaces than natural ones.
- 4 **List** the fabrics in order from the safest near a flame to the most dangerous.
- 5 Clothing fires are more common among children than adults and more common among girls than boys. **Propose** reasons why.
- 6 **Recommend** which fibres should be used to make clothing for babies and young children.

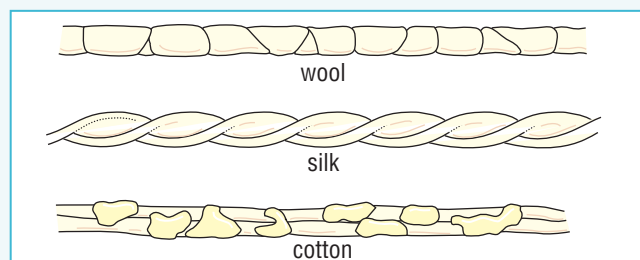

Fig 2.4.10

3 Investigating fibres

Method

- 1 **Design** your own experiment to determine one of the following:
 - the amount of water different fabrics can hold
 - the strength and/or elasticity of different fibres (e.g. fishing lines)
 - whether twisting or plaiting three fibres together might change the overall strength of the three straight fibres.



- 2 Seek approval from your teacher and then carry out your method.

Questions

- 1 **Construct** a flow chart showing how you conducted your experiment.
- 2 **Construct** a report for the experiment you performed, including the normal conventions of a report such as aim, hypothesis, method, results, analysis and conclusion.

Prescribed focus area

The implications of science for society and the environment

Organic chemistry is the basis of all living things. Without organic chemistry, life on Earth would not be possible and it is all based on the unique chemical properties of one element—carbon. Scientists have found ways to imitate nature and use organic chemistry to develop a large variety of synthetic materials such as plastics and rubbers.



Science Clip

My necklace was once my grandmother!

Humans are built from organic substances and are therefore a good source of carbon. Diamonds are one of the forms pure carbon takes. A company in the United States, LifeGem Memorials, is developing a process to exploit these two facts: it intends to convert cremated human remains into diamonds, which can then be worn as jewellery by grieving relatives!



Fig 2.4.11 A gas flare from a refinery. Gas like this is a fossil fuel. All fossil fuels are organic: their molecules contain a backbone of carbon.

Organic chemistry

Organic chemistry is the chemistry of compounds made from chains or rings of carbon atoms—no other element can make molecular chains as long as carbon. Carbon is in Group IV of the periodic table and so has four electrons in its outer shell. This means that it can bond with up to four other atoms, usually other carbon atoms, hydrogen or oxygen. In this way, carbon is unique in that it is able to form millions of different stable compounds with various physical and chemical properties. Table sugar (sucrose, $C_{12}H_{22}O_{11}$) and glucose ($C_6H_{12}O_6$) are organic compounds, as are methane (CH_4) and vinegar (acetic acid, CH_3COOH). All living things are made up of organic compounds. Fossil fuels are the remains of animals, algae and plants that were once living and so are also made from organic compounds.

Fig 2.4.12 All living things contain organic compounds in the form of proteins, lipids and carbohydrates.

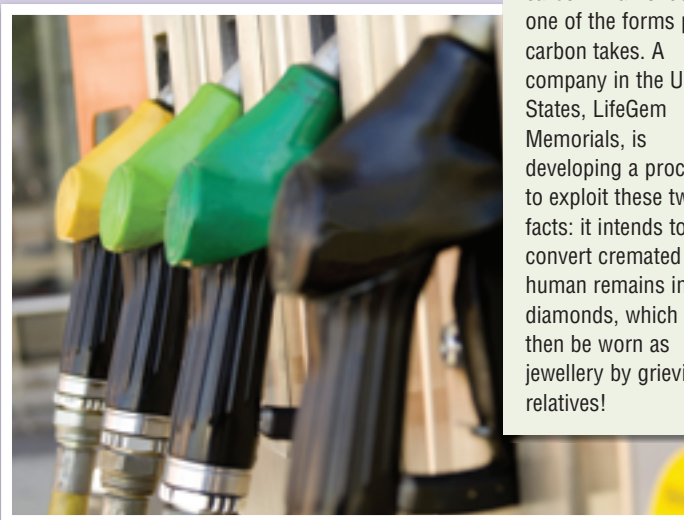

Fig 2.4.13 Crude oil is formed from the remains of plants and animals that lived millions of years ago.

Single bond	Double bond
$\cdot\overset{\cdot}{\text{C}}:\overset{\cdot}{\text{C}}\cdot$	$\overset{\cdot}{\text{C}}:\overset{\cdot}{\text{C}}$
one shared pair of electrons	two shared pairs of electrons
$\begin{array}{c} \text{H} & & \text{H} \\ & \diagdown & / \\ & \text{C} - & \text{C} - \\ & / & \diagdown \\ \text{H} & & \text{H} \end{array}$	$\begin{array}{c} \text{H} & & \text{H} \\ & \diagdown & / \\ & \text{C} = & \text{C} - \\ & / & \diagdown \\ \text{H} & & \text{H} \end{array}$
Ethane contains only single bonds	Ethene contains one carbon-carbon double bond and four carbon-hydrogen single bonds
Triple bond	
$\cdot\text{C}:\overset{\cdot}{\text{C}}\cdot$	
three shared pairs of electrons	
$\text{H}-\text{C}\equiv\text{C}-\text{H}$	
Ethyne contains one carbon-carbon triple bond and two carbon-hydrogen single bonds	

Fig 2.4.14 Multiple bonds

The simplest organic molecule is **methane** (CH_4), which contains just one carbon atom attached to four hydrogen atoms. The next simplest is ethane (C_2H_6), which is a chain of two carbon atoms, each with three hydrogen atoms. Carbon atoms can continue to bind together to form very long and complex chains. For example, your DNA is an organic molecule that is around one metre long.

The term **inorganic** is used to describe all other materials. This includes all pure elements, metal alloys



Fig 2.4.15 These items are all hydrocarbon-based.

and salts made up of metallic and non-metallic ions such as sodium chloride (NaCl), iron(III) oxide (Fe_2O_3) and potassium hydroxide (KOH).

Hydrocarbons

Hydrocarbons are the simplest organic compounds. Hydrocarbons are compounds that consist only of carbon and hydrogen. For example, methane (CH_4) and ethane (C_2H_6) are both hydrocarbons. Hydrocarbon compounds are important in our everyday lives. Cars

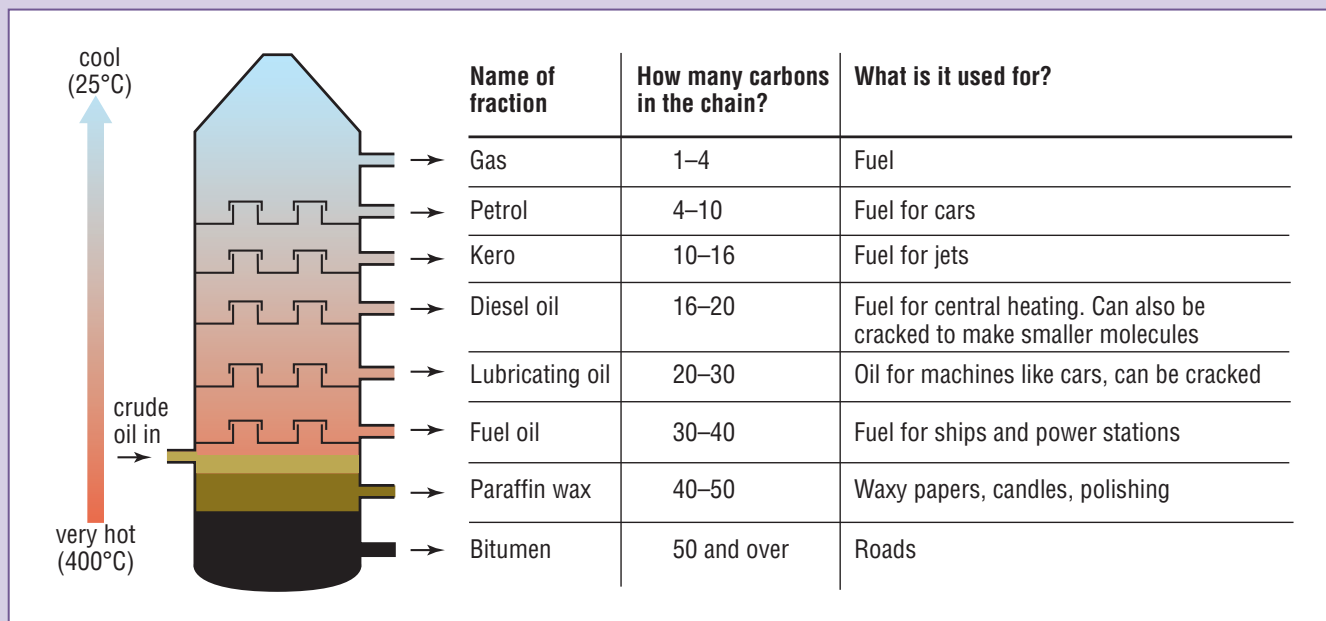

Fig 2.4.16 The crude oil is **refined** (separated into its components) by **fractional distillation**. This means that the crude oil is heated and passed into a column where the components are separated according to their boiling points into the different fractions.



run on hydrocarbon fuels and other hydrocarbons lubricate their engines. The many plastics we use are derived from hydrocarbons.

Using hydrocarbons

We use hydrocarbons frequently in our everyday lives. They are particularly useful as a source of fuel and for making polymers and plastics. The physical properties of a hydrocarbon and how it can be used, is largely determined by the length of the carbon chain. Longer chains tend to stick together. As a result, hydrocarbons with more than 40 carbon atoms are solids at room temperature, smaller hydrocarbons with five to 40 carbon atoms are liquids at room temperature, while hydrocarbons with four carbon atoms or less are gases.

Making plastics and polymers

Scientists use organic molecules to make synthetic materials such as plastics. The process for making plastics begins with relatively small organic molecules. For example polyethylene, which is used in shopping bags, is made from the molecule ethene (C_2H_4) which is a carbon chain made up of just two carbon atoms—each with two hydrogen atoms. However, ethene molecules can react with each other to form longer chains. Polyethylene is produced when around 500 000 ethene molecules have joined together in a long chain.

One of the biggest differences between plastics and the organic molecules made by nature is that plastics will not biodegrade. This means they are not broken down by the elements in the environment such as oxygen from the air or water. As a result, plastics can pollute the environment for hundreds of years.

Science Clip

Checking out

Organic chemicals have changed the way we live and the resources we use but we must also think carefully about how we use them. Many organic chemicals are not biodegradable. This means they do not break down naturally, but instead, stay in the environment for hundreds and sometimes thousands of years.

Twenty million Australians use an estimated nearly seven billion plastic checkout bags every year! Plastic bags in the ocean are a great cause of concern as they are mistaken for jellyfish by turtles, whales, sea birds and other animals that eat them. Once in the gut, the bags slowly and painfully kill the animal. The bag is then released back into the ocean, to kill again when the animal's body decomposes.



Fig 2.4.18 Plastic bags kill thousands of sea birds and marine animals every year.



Fig 2.4.17 The use of biodegradable paper bags and cotton canvas shopping bags will eventually save sea birds, seals, dolphins and fish.

STUDENT ACTIVITIES

Investigate your available resources (for example, textbooks, encyclopaedias, internet) to complete the following tasks.

- 1 Research the following classes of organic chemicals: alkenes, alkynes, alcohols, carboxylic acids and esters. Specifically find:
 - a what feature defines each class (e.g. all alcohols have an OH grouping)
 - b the names of the first four members of each class (e.g. ethane, propene)
 - c what the class of chemicals is used for
 - d what chemicals are needed to produce esters.
- 2 Research the physical properties and uses of 10 hydrocarbons. Present your research in a chart showing the chemical name, chemical formula, physical properties and pictures of potential applications.

 **Worksheet 2.6** Organic chemistry



Fig 2.4.19 Esters give lollies like these ‘bananas’ their flavour.

PRACTICAL ACTIVITY

Making molecules

Aim

To build models of various hydrocarbons

Equipment

- molecular model-building kit (alternatively, plasticine of different colours)

Method

- 1 Use a molecular model building kit or plasticine to construct models of some methane and ethane.
- 2 To construct more of these hydrocarbons (known as the alkanes), add another carbon atom and another two hydrogen atoms. Repeatedly add more CH_2 units to make more alkanes.
- 3 Draw and name the models you make.

Question

The general formula for all alkanes is $\text{C}_n\text{H}_{2n+2}$. As a class, **discuss** what this general formula means and test the rule by building a model.

context

Soap, shampoos and detergents help you wash away dirt, oil and grease far better than if you just use water. They can do this because they have an amazing chemical structure.



Fig 2.5.1 Soap and shampoos help dirt and grease dissolve in water. Without them, the dirt and grease would stay on you. Lather (bubbles) keeps dirt and grease from re-depositing on the hair.

Washing in water

At home, water (H_2O) is our main washing liquid. It is a **polar** molecule which has small electrical charges on its ends. Water dissolves other polar molecules (e.g. sugar) and ionic substances (e.g. salt or sodium chloride, NaCl) that have positive and negative ions.

Water will not dissolve grease by itself.

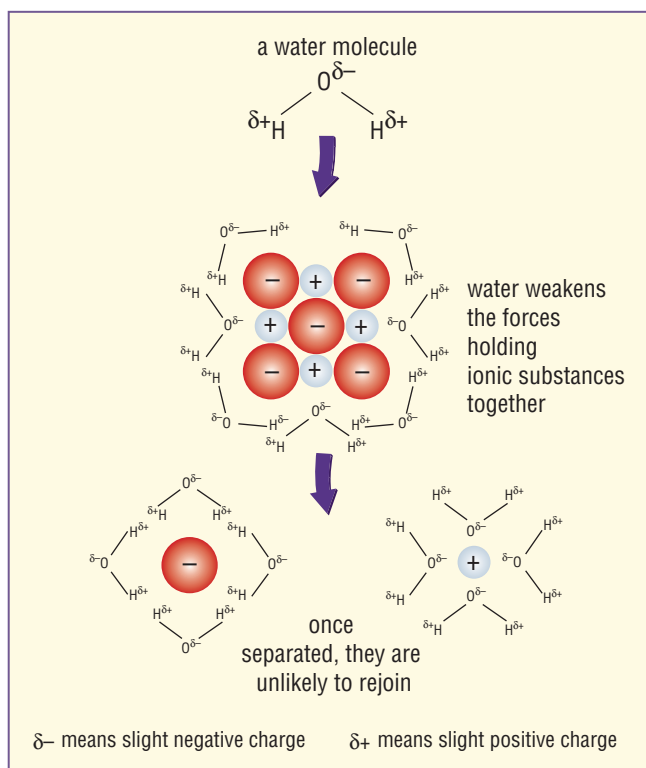

Fig 2.5.2 Water is a polar molecule and can use its slight charges to dissolve ionic substances.

Making grease soluble

Dirt, oils and grease are made from organic compounds that normally dissolve only in other organic substances such as turpentine, methylated spirits or nail-polish remover.

Although there are obvious problems in washing yourself in liquids like these, drycleaners use similar organic solvents to dissolve and remove grease from clothes. Most cleaning is done in water with the aid of soap, shampoos or detergents. These are examples of **surfactants**, which are molecules that assist water in dissolving dirt and grease.



Fig 2.5.3 Detergents, shampoos and soaps are surfactants.

Surfactants have both organic and ionic parts. Surfactant molecules are similar to those of plastics in that they are long and have an organic carbon backbone. This will dissolve grease well because it too is an organic compound. Unlike most molecules, however,

they have a charged or ionic end. This is then joined to a metal ion (usually a sodium ion Na^+). This end will dissolve well in water. We now have the perfect molecule for dissolving grease—one end dissolves the grease, while the other end dissolves in water. Once the grease is dislodged, surfactant molecules surround it and keep it from re-depositing back onto the surface. These tiny dissolved liquid grease patches and the water form a mixture called an **emulsion**. The water can now wash away the muck.

Hot water and agitation (vigorous movement) help loosen the grease from the surface and keep it from re-depositing on it. Lather (bubbles) will also assist in keeping grease from dropping back and is particularly useful in situations where little water is used (e.g. shaving, washing cars, hair shampoo). Many fibres (including hair) take on a weak negative charge when wet. Once dissolved and carrying their load of grease, the soap or shampoo molecules also carry a negative charge and are therefore less likely to re-deposit the grease back onto the fibre.



Science Clip

What gorgeous hair!

The molecules of most hair conditioners tend to have positively charged ends that are attracted to the weak negative charge of the hair. They stay there even when the hair dries. (Fabric softeners work in the same way). Shampoos and conditioners are normally sold in separate bottles because their opposite charges interfere with each other if they are mixed. In combined shampoo-conditioners, the conditioner molecules are trapped in crystalline shells. When lathering hair, the shampoo works, but there is insufficient water to break down the conditioner crystals. These only break down on rinsing, when more water is present.

Science Clip

Skin soap

Bases such as caustic soda (sodium hydroxide) and their alkaline solutions are extremely dangerous if they come in contact with the skin. The skin becomes slippery, its fats reacting to form soap! Saponification has occurred.

Hard and soft water

Tap water contains many impurities. If it has a lot of calcium and magnesium salts dissolved in it, then it is hard. Soap reacts with these salts to produce calcium and magnesium precipitates. These are left behind as a dirty grey substance called scum that deposits as a dirty ring around basins and baths or as scale in pipes and kettles. Soft water has less dissolved salts and soap produces less scum. Soap lathers better, feels smoother and more slippery, and less of it is required to get clean.



How soap is made

Soap is made when natural fatty acids found in materials like vegetable oils and animal fats react with an **alkaline** (basic) solution such as sodium hydroxide. The process is called **saponification**, summarised by the reaction:



Detergents are produced from chemicals from crude oil. The big advantage of detergents is that they don't produce scum.

Some Australian cities have excellent soft water: it lathers well and leaves very little scum. Other cities are less fortunate. In some, 'water softener' systems are attached to each home's water supply. Beads of zeolite replace the offending calcium and magnesium ions with sodium. Soap doesn't react with sodium.

Soap needs a fat or oil to start its production and today much of it comes from fat boiled down from the carcasses of cattle. In the past, whale blubber was used. Vegetable oils can also be used: Palmolive soap is so named because it is made from palm oil and olive oil.

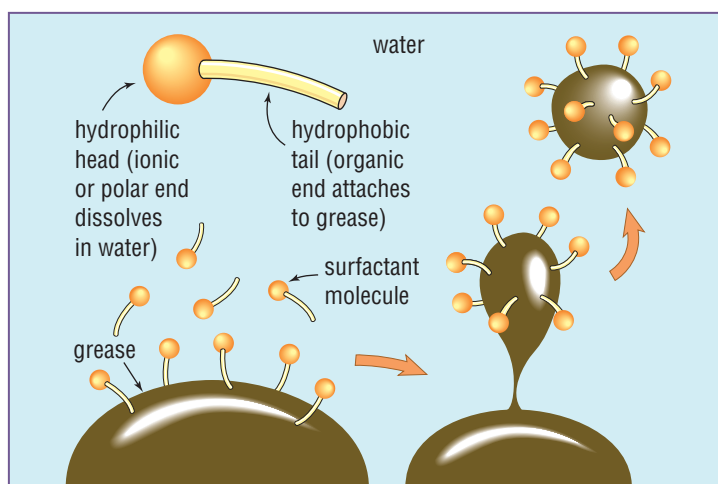

Fig 2.5.4 Surfactant (soap, detergent) molecules have a hydrophobic end that hates water but loves grease. The other end is hydrophilic—it loves water.

2.5 QUESTIONS

Remembering

- 1 **Specify** the types of substances that water normally dissolves.
- 2 Grease is a specific type of compound. **Specify** which type.
- 3 **a List** liquids that normally dissolve grease.
b List where these solvents are used.
- 4 **List** three ways grease is prevented from re-depositing on a surface.
- 5 **List** the advantages of soft water.
- 6 **State** which chemicals cause scum.
- 7 **State** what scum forms in pipes and kettles.
- 8 **List** the reactants in saponification.
- 9 **Recall** saponification by writing a word equation for the production of soap.

Understanding

- 10 **Explain** what a polar molecule is.
- 11 **Define** the term *surfactant*.
- 12 **Explain** how soap is able to dissolve both in water and in grease.
- 13 **Explain** where cut whiskers would end up if shaving cream did not lather.

Applying

- 14 **Identify** how soap are molecules similar to:
 - a plastics
 - b ionic compounds
- 15 Draw a diagram to demonstrate how soap helps grease to dissolve in water.
- 16 Since lather does not help in dissolving grease, **identify** its use.
- 17 **Identify** three vegetable oils that could be used for the production of soap.
- 18 **Identify** as many factors as you can that will affect the cleaning of a piece of fabric.

Analysing

- 19 **Compare** detergent and soap by listing their similarities and differences.

Evaluating

- 20 A lot of soap uses animal fat as its base. **Propose** where this animal fat could come from.

Creating

- 21 **Construct** a three- to four-frame cartoon/diagram showing how shampoo-conditioners work.
- 22 Inspect the labels of at least three different brands of soap, hair shampoos and shower gels. Write down the first six ingredients of each. What do you notice? **Construct** a table to present your work.

2.5 INVESTIGATING

Investigate your available resources (for example, textbooks, encyclopaedias, internet) to find the meanings of the words *phobia* and *phobic* and give examples of phobias.

One end of a surfactant molecule is hydrophobic while the other end is hydrophilic. What do these terms mean and which end is which?

e-xploring

To find out more about soaps and detergents, a list of web destinations can be found on **Science Focus 4 Second Edition Student Lounge**. Explore the internet to find:



- what a soap-free cleanser like Dove is made of
- how special cloths made by Scotch, Sabco, 3M and ENJO clean without the use of chemicals
- how the dry-cleaning process cleans clothes
- why soap films are often coloured
- a machine that can make three-storey-high soap bubbles. Present your research as a written explanation that includes diagrams and explains the chemistry involved.

2.5 PRACTICAL ACTIVITIES

1 Make soap



Safety

The soap made here uses and contains very corrosive sodium hydroxide. Do not get any sodium hydroxide on your skin or in your eyes. Do not use the soap produced in this Prac.

Aim

To make soap

Equipment

- olive oil or coconut oil
- 6 M sodium hydroxide solution
- saturated solution of sodium chloride
- kerosene
- 3 test tubes
- rubber stopper
- 400 mL beaker
- 100 mL beaker
- 250 mL beaker
- hot plate (preferably) or a Bunsen burner
- bench mat
- tripod
- gauze mat
- matches
- filter paper or paper towel

Method

- 1 Pour about 5 mL of oil into a test tube.
- 2 Carefully add 10 mL of sodium hydroxide solution.
- 3 Place the test tube in a boiling water bath for 30 minutes. Shake the tube every few minutes to mix the contents.

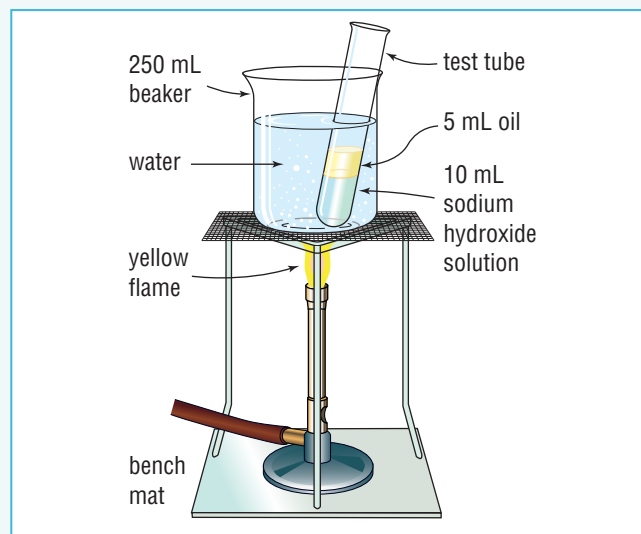

Fig 2.5.5

- 4 Place 50 mL of the sodium chloride solution in the 100 mL beaker, then pour in the hot oil mix. The soap formed should float to the top.
- 5 Scoop up the soap and place it in the 250 mL beaker. Rinse a few times with a little water.
- 6 Let the soap dry on filter paper/paper towel.
- 7 Two-thirds fill the other test tube with water and add a little soap.
- 8 Stopper and shake. Does it lather?
- 9 Fill a fresh test tube with water, then add 3 or 4 drops of kerosene. This will be our 'grease'. Stopper and shake.
- 10 Add some soap, then shake again. Compare with what you saw before.

Questions

- 1 Draw a cartoon explaining how soap was made.
- 2 What happens when you only put kerosene in water?
- 3 What effect did the soap have on it?
- 4 Write a word equation for the reaction.

2 How hard is it?

Aim

To observe hardness in water

Equipment

- distilled water
- dilute magnesium sulfate solution
- solution of calcium hydrogen carbonate
- suspension of calcium carbonate in water
- small chips of bath soap
- shampoo
- detergent
- 5 test tubes
- rubber stoppers to fit test tubes

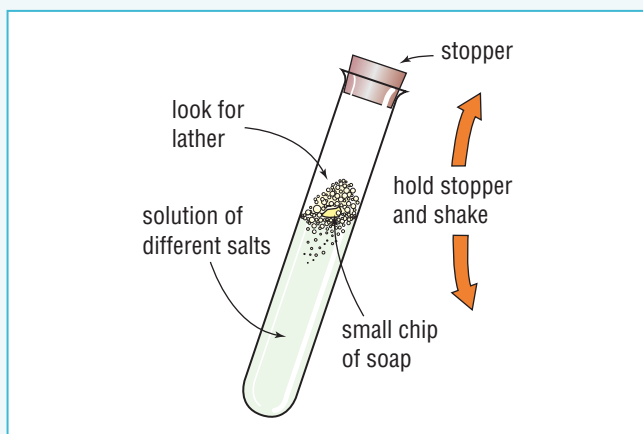

Fig 2.5.6

Method

- 1 Put about 2 cm of distilled water and 2 cm of tap water into two separate test tubes.
- 2 Put about 2 cm of each solution into the other test tubes.
- 3 Add a small chip of soap to all 5 tubes and stopper lightly.
- 4 Shake the tubes vigorously and watch for any lather that forms.
- 5 Record your results in order from the solution that produced the most lather (the softest) to the one that produced the least (the hardest).
- 6 Repeat the experiment but use a few drops of shampoo.
- 7 Repeat again with a few drops of detergent.

Questions

- 1 What does soap do in hard water?
- 2 Which was the hardest of the solutions?
- 3 Did water show any hardness with the shampoo or detergent?
- 4 What is the advantage of detergent over soap?
- 5 **Design** a test to see if temperature has an effect on water hardness.



3 Powder and liquid laundry detergents



Identify all the variables or factors that could influence the effectiveness of laundry detergent in removing grease. Choose one variable that you think would have a large effect and **design** your own experiment to test it. Present your work as an experimental report on the effect of the variable you chose. Include all the normal features like aim, materials, method, results, discussion (answers to following questions) and conclusion.

Questions

- 1 Write a conclusion for the variable you tested.
- 2 Gather conclusions from other groups that tested different variables. Which variables had an effect and which didn't?



Fig 2.5.7

CHAPTER REVIEW

Remembering

- 1 State** an example of an alloy and its base metal.
- 2 State** whether the additives in alloys are usually metals or non-metals.
- 3 State** the carbon content of:
 - a cast iron
 - tool steel
 - mild steel
- 4 State** how many carats are in pure gold.
- If gold is 18-carat, **state** the percentage of gold present. **(N)**
- 6 Name** a metal that is extracted by:
 - electrolysis
 - smelting
 - roasting
- 7 List** the ingredients for a blast furnace.
- 8 List** four properties of a thermosetting plastic.
- 9 List** two examples of natural and synthetic fibres.

Understanding

- 10 Explain** why primitive people discovered gold and silver before any other metal.
- 11 Outline** problems associated with using plastic shopping bags.
- 12 Use** a diagram to describe the bonding in metals that allows:
 - conduction of electricity
 - conduction of heat

Applying

- 13 Identify** a use for each of these materials:

aluminium	celluloid
Duralumin	cast iron
bauxite	haematite
zinc	Kevlar
bronze	
- 14 Identify** one example each of:
 - an alloy of copper
 - an ore
 - an alloy of iron
 - a native metal
 - an impurity commonly added to iron
 - a natural fibre

- a synthetic fibre made from wood products
- a commonly used pure metal
- a non-metal abundant in the Earth's crust
- a monofilament fibre
- a scarce metal
- a metal that is cheaper to recycle than to produce
- a surfactant
- an organic solvent

Analysing

- 15 Compare** the following by listing similarities and differences:
 - synthetic and organic compounds
 - alloys and pure metals
 - ore and metal
 - carat and carrot
- 16** It is thought that iron simply oozed out of the rocks used to surround the cooking pits of ancient hunters. **Compare** these conditions with those of a blast furnace.

Evaluating

- 17** Rose-gold is a pink-gold colour. **Propose** what metal is added to the base metal to create this colour and other gold alloys used in jewellery.
- 18 Investigate** different types of lead-tin solder. **Construct** a table of the melting points for different combinations of lead and tin. Include in your table the melting points for pure lead and pure tin.

Creating

- 19** Use the data in the table on page 48 to **construct** the following graphs: **(N)**
 - a pie chart showing the amount of metals used each year
 - a bar graph showing when each metal is estimated to run out
- 20 Construct** a diagram showing what happens in the electrolysis of copper chloride. Label the diagram and use chemical equations to show the chemical reactions at each electrode.

 **Worksheet 2.6** Crossword

 **Worksheet 2.7** Sci-words



Genetics

3

Prescribed focus area

Current issues, research and development in science

The history of science

Key outcomes

5.1, 5.5, 5.8.2, 5.12

- Genetics and the environment both influence the features of an organism.
 - DNA has a twisted helix structure known as the Watson-Crick model.
 - DNA replicates by splitting in two and complementary base pairs forming.
 - Although mutations in DNA replication are usually harmful, some mutations can be beneficial.
 - DNA is a store of genetic information which is transferred on the chromosomes when cells reproduce.
 - Genes are coded in the order of nitrogen bases on the DNA molecule.
 - Biotechnology offers a broad range of different career paths.
-
- While most cells in the body reproduce by mitosis, sperm and egg cells reproduce by meiosis.
 - Sperm and egg cells only have half the number of chromosomes required for an organism and must join for it to form.
 - DNA controls what a cell does and what it is.
 - Genetic information is passed on from generation to generation. It is often masked, only appearing now and then.

Essentials

Additional

context

Every organism on Earth has inherited genetic information from its parents. This genetic information determines whether the organism ends up as an elephant or

an eagle, a bacterium or a birch tree, a mushroom or a maggot, a hog or a human. Inherited information also decides how big the organism will grow, what colour it will be, and even some of the diseases it will contract during its lifetime.



Fig 3.1.1 Everyone is different but we are all much the same too. Genetics explains why.

Heredity and environment



Genetics is the study of heredity. **Heredity** is the set of characteristics that living things inherit from their parents. These characteristics form the basic structure of the organism, influencing its form and colour and how it grows and develops. Another influence that acts on the organism is environment. **Environment** is the diverse set of factors that act on the organism throughout its life, such as the availability and quality of food, exposure to disease, pollutants and radiation and the amount of nurturing and care that it receives as it grows.

Heredity and environment often affect the same characteristics and it is sometimes difficult to determine where the influences of one end and the other begin. While heredity lays the basic foundations of a person's shape and size, environment affects them too. Over the last century, better nutrition and reduced exposure to disease has allowed most people in the western world to

reach the potential height as determined by their genes. However, a lack of nutritious food in developing countries and during famine still means that many children rarely reach the size and shape that their heredity suggests. Likewise, eat too many burgers and fries and your shape will change.

Mendel: father of genetics

The story of genetics began in 1856 with a monk named Gregor Mendel who taught science in an Austrian monastery. In his spare time, Mendel carried out experiments to study how characteristics are inherited.



Fig 3.1.2 Gregor Mendel was not the first to study heredity but he was the most successful.

Science Clip

Ignored for 34 years!

Mendel published his work in 1866, but it was poorly understood and largely ignored by the scientific world. It was not until 1900 that his work was 'rediscovered' and its importance appreciated. Three scientists (H. de Vries in Holland, C. Correns in Germany and E. van Tschermak-Seysenegg in Austria) working independently reached the same conclusions that Mendel had 34 years earlier.

Mendel grew garden peas. Like all living things, peas display certain similar characteristics that define them as peas. They all, for example, form pods that hold their seeds (the actual peas). Not all peas are the same, however, since some of their characteristics come in two very specific forms. Mendel called these characteristics **traits**. The traits that Mendel examined in his garden peas included:

- seeds (peas) that were round or wrinkled
- seeds that were yellow or green
- pods that were smooth or constricted
- pods that were green or yellow
- stems that were long or short.

True-breeding plants are those that consistently produce offspring the same as the parents. For example, yellow-pod plants that always produce more yellow-pod plants are considered to be true-breeding. Mendel cross-pollinated true-breeding plants with contrasting traits. He took, for example, the pollen from a plant with round seeds and placed it on the flower of another plant with wrinkled seeds. He found that all the offspring (called the F_1 generation) were like one of their parents. When these offspring were cross-pollinated among themselves, their offspring (the F_2 generation), showed both traits. Almost always the traits appeared in the ratio of 3:1.

Dominant and recessive

Mendel found and named two traits:

- **dominant trait**—this is the trait that appeared in the F_1 generation
- **recessive trait**—this is the trait that was ‘masked’ in the F_1 generation and reappeared in the F_2 generation.

Mendel suggested that each characteristic possessed two hereditary factors and that these factors separated and passed into the plants’ male and female reproductive cells. Reproductive cells are referred to as **gametes**. **Ova** (eggs) are gametes in females and **sperm** (or **pollen** in flowering plants) are gametes in males. A new organism is formed when gametes join to form a new cell. The sperm and egg each carry one hereditary factor and so the new organism receives one factor from each parent. The factors do not blend with each other, but act as independent units.

Genes

Mendel’s factors are now known as **genes**. A gene is a hereditary unit that controls a particular characteristic. Each cell in an organism contains thousands of genes. Genes can be thought of as a set of instructions, a genetic program that determines what the organism will

be and what it will look and act like. For humans, genes determine eye colour, body size, skin type and the many other characteristics that make up each individual. Each gene is made of a chemical called **deoxyribonucleic acid (DNA)**.

Science Clip

Bees or peas?

Before starting work with his peas, Mendel tried to breed a hard working but easily managed honey bee. He tried crossing an industrious German bee with a gentle Italian bee. The result was a bee that was neither hard working nor gentle! He moved his attention to peas, which were much easier to handle.













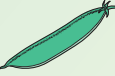

Parental cross	F_1 generation	F_2 generation	Probability ratio
 ×  round × wrinkled	 round	5474 round 1850 wrinkled	3:1
 ×  yellow × green	 yellow	6022 yellow 2001 green	3:1
 ×  smooth × constricted	 smooth	882 smooth 299 constricted	3:1
 ×  green × yellow	 green	428 green 152 yellow	3:1
 ×  long stem × short stem	 long stem	787 long 277 short	3:1

Fig 3.1.3 This table is a summary of Mendel’s study of 28 000 pea plants. Some characteristics were found to be dominant. Others were recessive.

Chromosomes

Genes are located on structures called **chromosomes** that are found in the nucleus of each cell. Each species of organism has a fixed number of chromosomes in their cell nuclei. The number of chromosomes in the nucleus of a cell also depends on what type of cell it is. Cells are classified as either **diploid** (with a full quota of chromosomes) or **haploid** (with only half the required chromosomes).

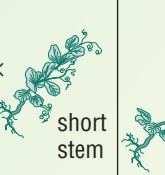
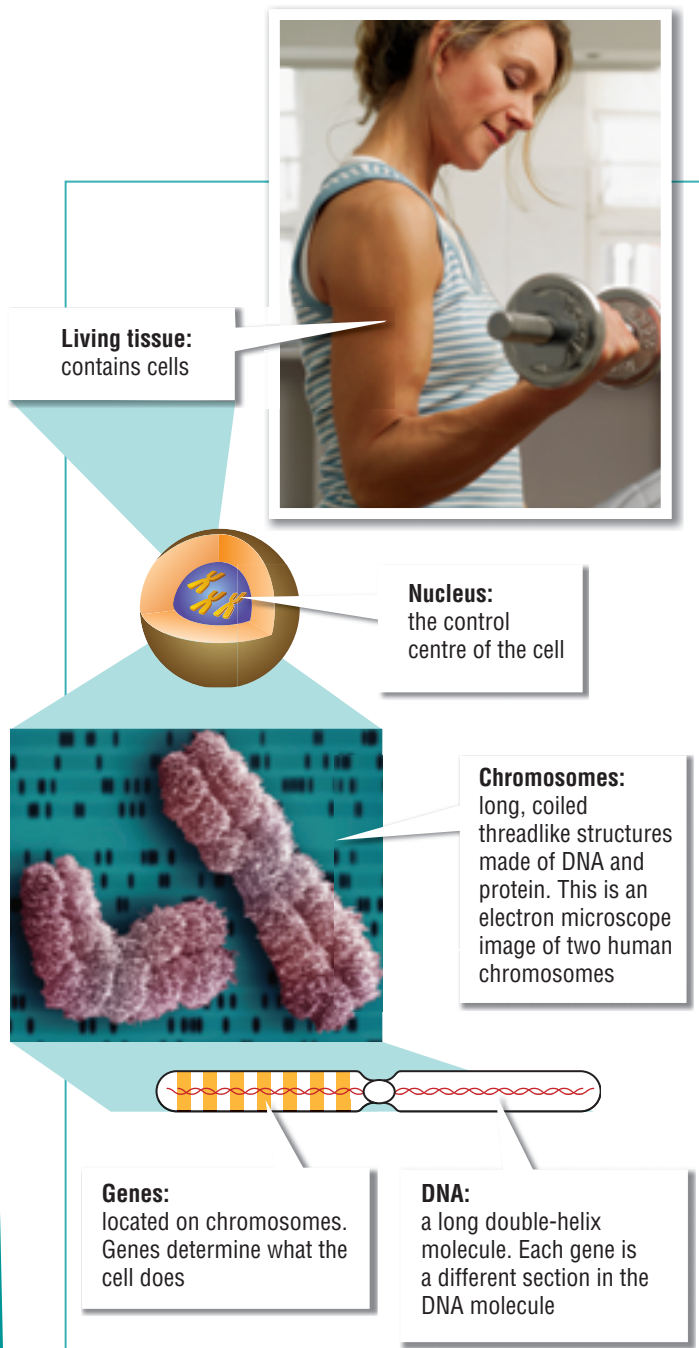

Fig 3.1.4 The relationship between genes, DNA, chromosomes, the nucleus and the cell

Most cells are diploid cells

Apart from their sex cells, every cell in a human or an animal is a diploid cell. Diploid cells make up muscles, nerves, skin, bone, fat, blood and organs but not their sperm or eggs.

In diploid cells, the chromosomes exist in pairs. One of the pair is inherited from the animal's father, the other is from its mother, making what is called a **homologous pair**. Diploid cells contain a complete set of chromosomes and therefore a complete set of coded instructions about how the animal is put together.

In a human, 23 chromosomes from a male pair up with 23 similar chromosomes from a female. Each cell therefore has 46 chromosomes organised into 23 homologous pairs.

Sex cells are haploid cells

Sex cells (gametes) are different to all the other cells in an animal. They contain only one of each type of chromosome and are known as haploid cells.

A sperm cell and an egg cell cannot make a new organism by themselves. This is because each has only half the necessary chromosomes. On fertilisation the new cell contains the full quota of chromosomes and now has the ability to develop into a new being. This first new cell is called a **zygote**.

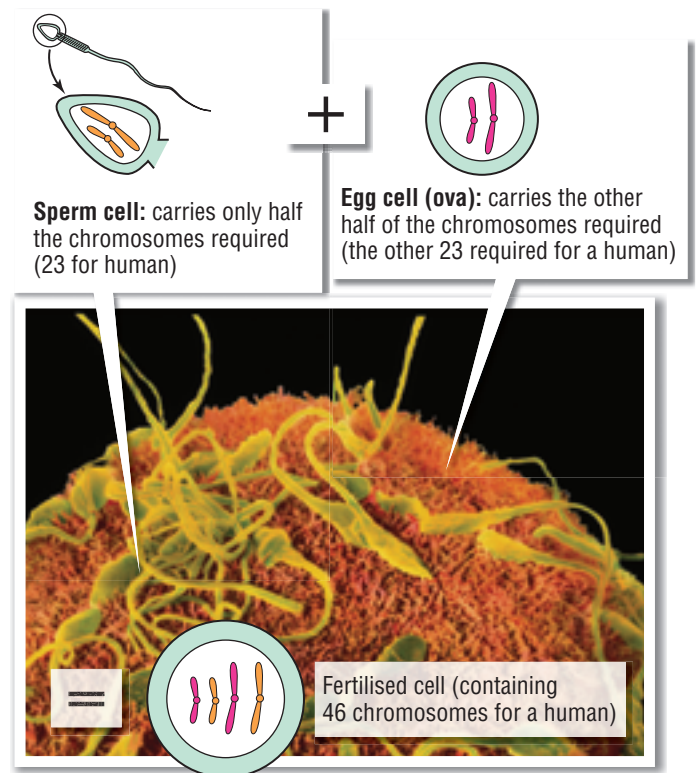

Fig 3.1.5 Although many sperm attempt to fertilise an egg, only one can be successful. The new cell then has a complete set of instructions for life.

Cell reproduction

The first complete cell of an organism, the zygote, must reproduce and copy itself over and over so that it can grow and form all the different types of cells it needs. Even once the adult has formed, cell reproduction is still needed to repair its tissues, replace dead cells and allow it to reproduce. The chromosomes in an organism are a copy of those that were present in the zygote cell from which it grew.

There are two ways cells reproduce and copy themselves. Ordinary body cells, such as brain cells, stomach cells, skin cells and muscle cells, reproduce by mitosis. Sex cells (sperm and ova) copy by meiosis.

Mitosis

When a diploid cell divides, the resulting daughter cells receive a perfect copy of their parent cell chromosomes. This type of cell division is called **mitosis**. Mitosis is a series of steps that ensures that each daughter cell is an exact copy of the parent cell.



Go to [Science Focus 3 Unit 5.1](#)



Science Clip

Another you?

You are you because of the complex combination of chromosomes you obtained from your parents. For any two parents, the number of possible combinations of chromosomes in offspring is 70 million million! You may share some chromosomal pairs (giving rise to some similarities) but a complete match is near impossible. Therefore it is extremely unlikely that there will ever be another you.

Meiosis

Meiosis occurs in the cells of the ovaries and testes, producing gametes that only contain one of each type of chromosome. Gametes therefore are incapable of producing a new organism by themselves. A full set of chromosomes is produced only on fertilisation, when sperm meets egg.

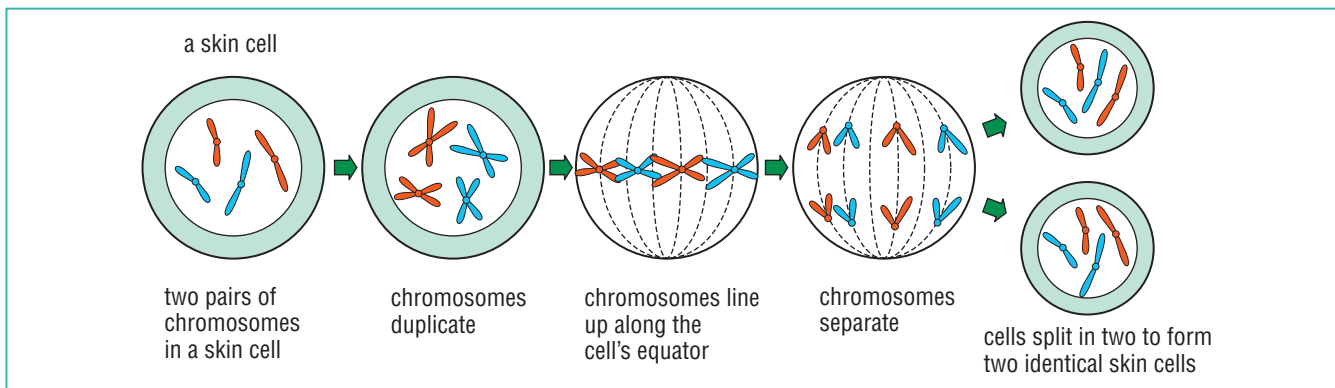

Fig 3.1.6 Mitosis produces cells that are identical to the parent cell. Mitosis occurs in all cells except sperm and egg cells.

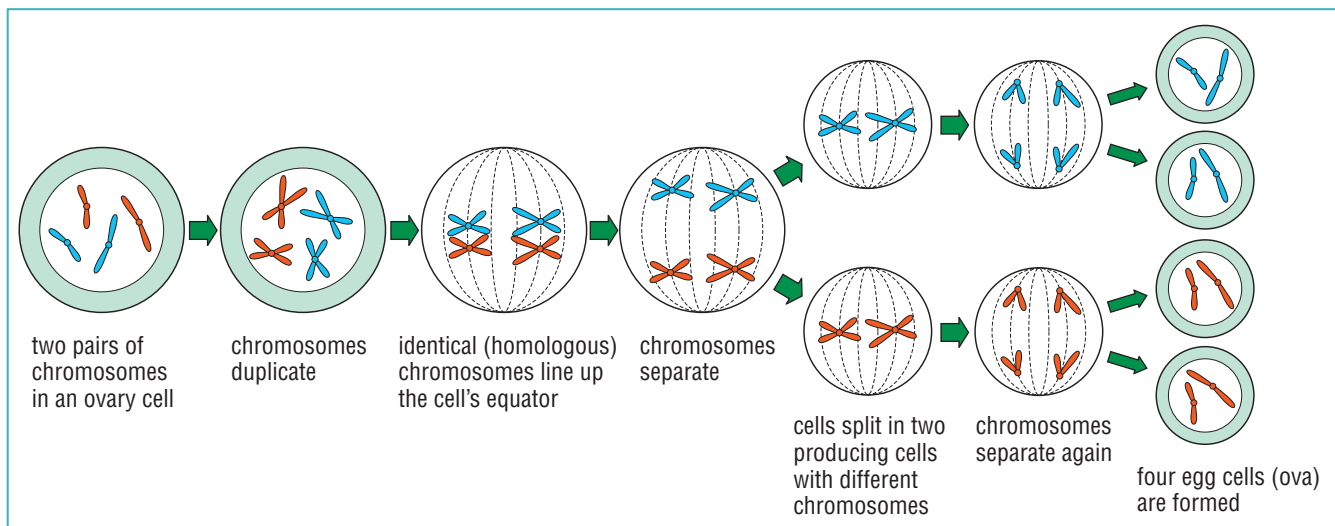

Fig 3.1.7 Meiosis produces cells with only half the number of parent cells. Meiosis produces gametes (sperm or egg cells).



Worksheet 3.1 Cell division

Simple inheritance

Half of an organism's chromosomes (and therefore half its genes) come from each of its parents via their sperm and ovum. However, an organism doesn't simply have half of its father's characteristics and half of its mother's. A closer look at genes is needed to understand why.

Genes come in different forms called **alleles**. In pea plants, for example, the gene that controls pod colour in pea plants has two alleles: one allele codes for green pods and the other for yellow pods. Mendel observed in his experiments that green pods were more common than yellow pods. This suggests that:

- the allele for green pods is a **dominant** gene—scientists show this dominance by using a capital letter. (For example, the allele for green pods might be represented as G.)
- the allele for yellow pods is a **recessive** gene. The allele for yellow pods can be shown as g.

Genotype

Each pea plant contains two genes for pod colour, one received from the female, the other from the male. The different combinations of the parents' genes are known as the **genotype** of the plant. For pea pods, the possible genotypes are:

- GG (called **homozygous** since both alleles are the same)
- Gg (called **heterozygous** since both alleles are different)
- gg (also called homozygous).

Phenotype

The appearance produced by a genotype is called the **phenotype** of the organism. The genotypes GG and Gg would both be green because G is a dominant allele, while gg would be yellow. Hence there are two different possible phenotypes, green (GG and Gg) and yellow (gg).

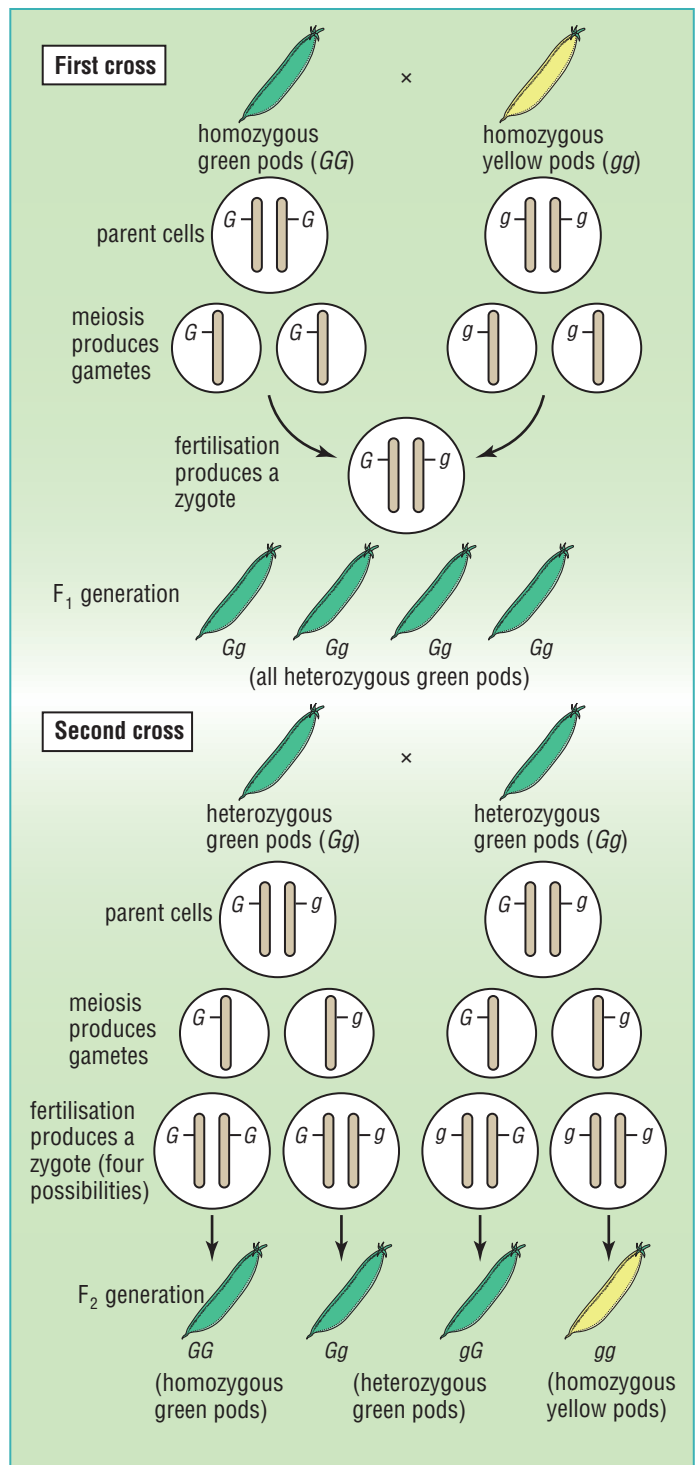

Fig 3.1.8 Mendel's results can be explained in terms of dominant and recessive genes. What the pod looks like depends on whether the dominant (green) gene is present. If present, the pod is green. If not, the pod is yellow.

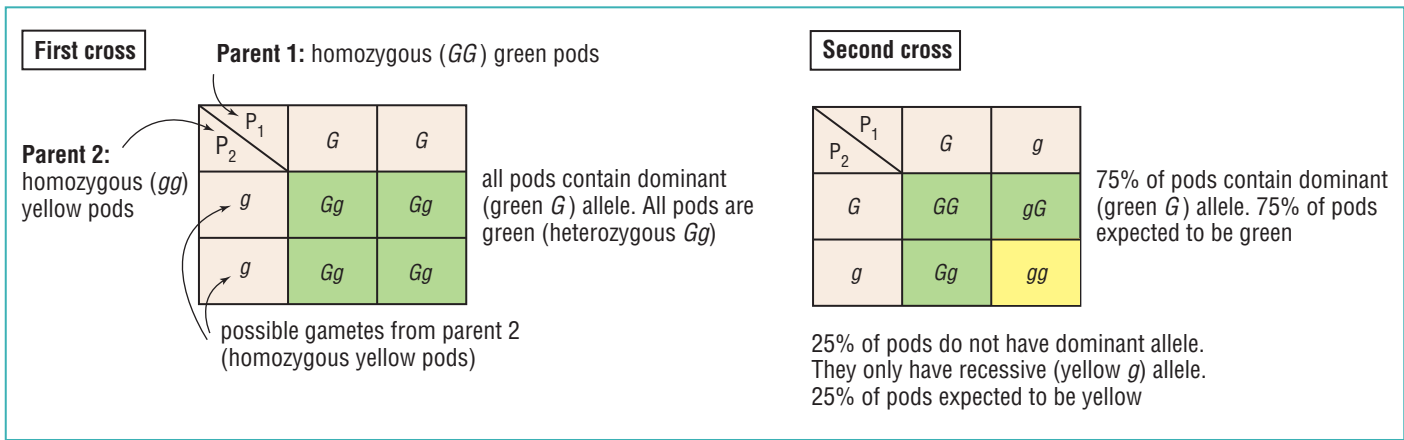

Fig 3.1.9 Punnett squares show the inheritance of pod colour in Mendel's peas. It shows the a 3:1 or 75:25% ratio that Mendel observed in his peas.

Punnett squares

One way to represent inheritance is to use a **Punnett square**. A Punnett square shows the possible combinations of genes for a particular characteristic.

Punnett squares can be used to predict the results of reproduction (crossing) between different organisms.

In rats, for example, the gene that codes for coat colour occurs as two alleles. The gene for black coat (B) is dominant over the gene for brown coat (b). The coat colours of potential offspring can be predicted using a Punnett square. Crossing two heterozygous black rats (Bb) should produce litters in which:

- 75 per cent of offspring can be expected to be black (either BB or Bb)
- 25 per cent can be expected to be brown (bb).

Worksheet 3.2 Heterozygous or homozygous?

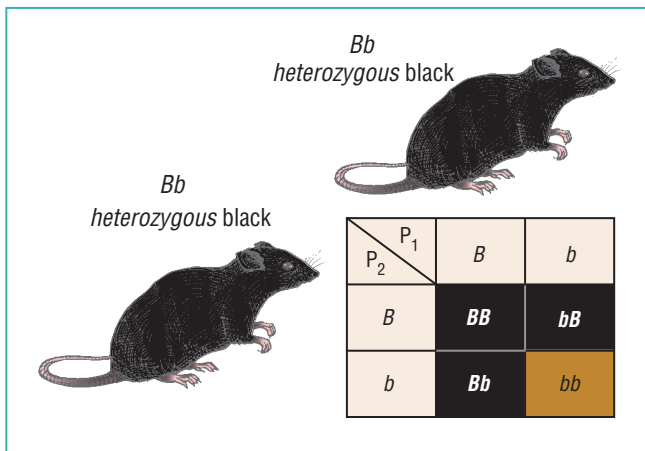

Fig 3.1.10 This Punnett square shows the inheritance of black and brown coat colour in rats.

Other types of inheritance

The inheritance of some characteristics can be explained simply by dominant and recessive alleles. In other cases, the effects of the two genes may blend in some way.

Codominance

In **codominance**, heterozygous organisms appear as a patchwork of their homozygous parents.

Codominance is displayed when shorthorn cattle are crossed. If a pure red (homozygous RR) shorthorn bull mates with pure white (homozygous WW) cow, it produces a calf that is a mix of the two. Neither allele is dominant and so the calf has patches of red and white, a colouring known as roan (heterozygous RW).

Crossing two roan cattle should produce:

- heterozygous roan offspring (50 per cent)
- homozygous red offspring (25 per cent)
- homozygous white offspring (25 per cent).

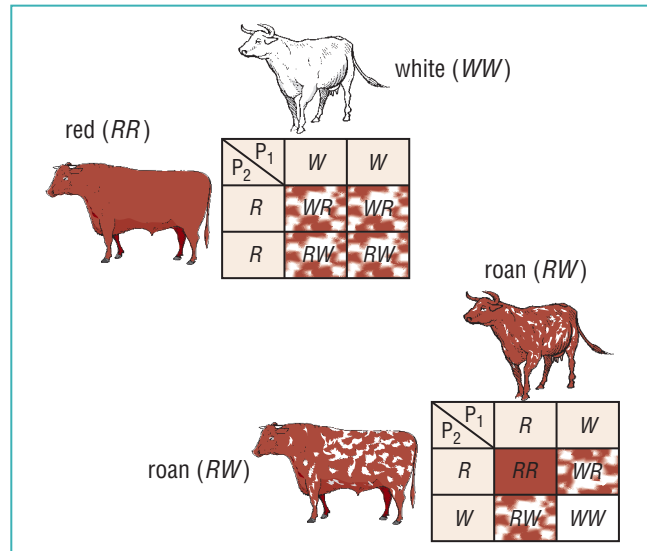

Fig 3.1.11 Inheritance of coat colour in shorthorn cattle is an example of codominance.

Incomplete dominance

Sometimes heterozygous offspring appear to be a blend of its homozygous parents. In snapdragons, the allele R produces red flowers while the allele W produces white flowers. The genotype RW produces pink flowers. This blending of colours is sometimes called **incomplete dominance**.

Complex inheritance

The study of inheritance would be relatively simple if every characteristic was controlled by a single gene. Many characteristics are controlled instead by a number of gene pairs resulting in much more variation than a simple Punnett square can predict. Height, skin and eye colour are characteristics that show very complex inheritance.



Career Profile

Geneticist

Geneticists study how biological traits pass from one generation to the next. They also determine how the environment contributes to the transmission of inherited traits. Geneticists may also alter or produce new traits in a species.

Geneticists can be involved in:

- studying the genetic, chemical, physical and structural composition of cells, tissues and organisms
- determining the influence of the environment on genetic processes in animals (including humans), plants and other organisms
- studying organisms in controlled environments to gain an understanding of their survival and growth in real environments
- applying the findings of research to maximise the long-term economic, social and environmental return from living resources
- writing scientific reports on research
- diagnosing or calculating the risk of passing on genetic diseases in humans, and advising parents on these risks.



Fig 3.1.12 A geneticist and agricultural scientist collects milk samples for analysis.

A good geneticist will:

- enjoy and have an aptitude for science and research
- be able to think logically and analytically and carry out detailed and accurate work
- have good communication skills
- maintain accurate records
- be able to work as part of a team.

3.1 QUESTIONS

Remembering

- 1 Name** the two influences that make you what you are. Give an example of each of these influences.
- Genetics is a field of science. **Specify** what it studies.
- 3 State** what is meant by a *true-breeding* plant.
- The traits that Mendel observed in pea plants are shown below. **State** whether each is dominant or recessive:
 - wrinkled peas
 - yellow pea
 - green pod
 - smooth pod
 - short stem
- 5 Name** the chemical from which genes are made.
- 6 State** how many chromosomes there are in a human:
 - muscle cell
 - sperm cell
 - skin cell
- 7 Recall** how Punnett squares are structured by drawing one that shows the crossing of two roan (*RW*) cattle.

Understanding

- 8 Define** the terms:
 - dominant gene
 - homozygous
 - allele
 - phenotype
 - zygote
- 9 Explain** what a gene is and what it does.
- 10 Explain** why a sperm or ovum cannot produce a new organism by itself.
- 11 Use** an example to explain how two organisms can have the same phenotype but different genotypes.
- 12 Use** an example to **clarify** the meaning of the terms:
 - codominance
 - incomplete dominance

Applying

- 13 Identify** the following cells as either diploid or haploid:
 - sperm cell
 - muscle cell
 - brain cell
 - ovum (egg cell)

- 14 Identify** which type of cell reproduction (mitosis or meiosis) occurs:
 - in the testes
 - in bone cells
 - in heart cells
 - produces a full set of chromosomes
 - produces half the chromosomes needed for the organism
- 15 Identify** which description best represents each symbol:

Symbol	Description
<i>gg</i>	dominant allele
<i>green pods</i>	recessive allele
<i>G</i>	genotype (heterozygous)
<i>Gg</i>	genotype (homozygous)
<i>g</i>	phenotype
- 16** *B* is an allele that produces black hair in rats. The allele *b* produces brown hair in rats. **Identify** the colour the following rats would be:
 - BB*
 - bb*
 - Bb*
 - bB*
- 17** In fruit flies, there are two alleles that control eye colour, the allele for red eyes (*R*) being dominant over the allele for white eyes (*r*).

	P_1	<i>R</i>	<i>r</i>
P_2	<i>r</i>	<i>Rr</i>	<i>rr</i>
	<i>r</i>	<i>rR</i>	<i>rr</i>

Fig 3.1.13

Use the Punnet square in Figure 3.1.13 to **state**:

- the eye colour of parent 1
- the eye colour of parent 2
- which parent is homozygous for eye colour
- the percentage of offspring expected to have white eyes
- the percentage of offspring expected to be heterozygous for eye colour

18 In cats, short hair (H) is dominant over long hair (h). Two cats heterozygous for hair length are crossed.

Use the Punnett square shown in Figure 3.1.14 to:

- state the genotype of the heterozygous cats
- list the possible genotypes of the offspring
- list the possible phenotypes of the offspring
- predict the probable percentages of each phenotype

	H	h
H	HH	Hh
h	hH	hh

Fig 3.1.14

19 Identify whether the following are examples of complete dominance or codominance.

- In snapdragons, red flowers crossed with white flowers produce pink flowers.
- In fruit flies, when red-eyed males are crossed with white-eyed females, all the offspring are red-eyed.
- When a green watermelon is crossed with a striped watermelon, half the offspring are green, and the other half are striped.

Analysing

20 Calculate how many different types of gametes could be produced by an individual with the genotype $XxYyZz$. (Possible gametes include XyZ , xyZ , etc.) **N**

Evaluating

21 Contrast the following by listing their similarities and differences:

- dominant and recessive genes
- homologous and heterozygous pairs
- diploid and haploid cells
- mitosis and meiosis

Creating

22 In hogs, the gene that produces a white belt around the animal (W) is dominant over the gene for uniform colour (w). A hog heterozygous (Ww) for colour is crossed with a hog homozygous for uniform colour (ww).

- Construct** a Punnett square showing this crossing.
- Use the Punnett square to:
 - list the possible genotypes of the offspring
 - state the percentage expected of each genotype
 - state the percentage of offspring that would be expected to have a uniform colour **N**

23 When Mendel crossed pure-breeding long-stem plants (LL) and short-stem plants (ll), he found that the long stem is dominant over short stem.

- Construct** a Punnett square showing the F_1 generation formed by crossing pure-breeding long stem plants (LL) with short-stem plants (ll).
- Plants from the F_1 generation were crossed to form the F_2 generation. **Construct** a Punnett square to show the crossing of two plants of the F_1 generation, producing the F_2 generation.
- Predict** the ratio of long- and short-stem offspring in the F_2 generation. **N**
- Does your prediction agree with Mendel's observations shown in Figure 3.1.3? **Justify** your answer.

24 In Andalusian fowls, black plumage (B) is codominant with white plumage (W). Heterozygous fowls (BW or WB) have blue plumage.

- State** the genotypes of black, white and blue Andalusian fowls.
- Construct** a Punnett square showing the different genotypes possible when two blue fowls are crossed.
- Predict** the chances of each phenotype occurring in the offspring when two blue fowls are crossed. **N**
- A poultry farmer wishes to establish a true-breeding strain of blue Andalusian fowl. **Explain** why this is not possible.

3.1 INVESTIGATING

Investigate your available resources (for example, textbooks, encyclopaedias, internet) to complete the following tasks.

- 1 Research the work of the following scientists and summarise how their findings furthered the understanding of genetics:



- T. H. Morgan
- H. de Vries
- W. L. Johannsen
- W. S. Sutton

- 2 Find out about 'hybrid' organisms such as the mule, formed by cross-breeding a horse and a donkey. Different species

have different numbers of chromosomes so cross-breeding between species is unusual. In your investigation, find out how this can produce a viable, living animal. Also find out what happens if the hybrids attempt to breed.

e-xploring

To find out more about Mendel and his work, connect to the *Science Focus 4 Second Edition Student Lounge* for a list of web destinations.



3.1 PRACTICAL ACTIVITIES



1 Observing mitosis

Aim

To observe mitosis in a series of prepared slides

Equipment

- microscope
- prepared microscope slide showing onion root tips

Method

- 1 Set up the microscope ready for viewing the slide.
- 2 Observe the slide under low power. Near the central part of the root is a section with cells in various stages of cell division. Focus on cells in this region.
- 3 Move to high power. Re-focus if necessary.
- 4 Draw five cells in different stages of cell division.

Questions

- 1 **Present** the five cells you have drawn in the order in which they would occur during mitosis.
- 2 **Explain** how you can be sure that the cells are undergoing mitosis and not meiosis.



2 Modelling meiosis

Aim

To construct models to demonstrate the process of meiosis

Equipment

- 3 pieces (1 short, 1 medium length and 1 long) of pipe cleaner
- rolls of plasticine or jelly snakes of one colour
- 3 more pieces (1 short, 1 medium and 1 long) of another colour to represent another 3 chromosomes
- large sheet of paper for sketching cells

Method

- 1 Draw a circle to represent a parent cell. Place the pipe cleaners in the cell to represent three pairs of homologous chromosomes. Sketch this cell in your book.
- 2 Draw two smaller circles to represent daughter cells. Move the pipe cleaners into these two cells to represent two gametes formed when the parent cell divides by meiosis. The gametes should each contain three pipe cleaners, one of each length.
- 3 Sketch the gametes in your book.
- 4 Repeat steps 2 and 3 until you have drawn all possible gametes.

Questions

- 1 **Predict** how many possible gametes can be produced from a cell with three pairs of chromosomes.
- 2 During meiosis, there is a 'random assortment' of chromosomes. **Explain** what the term 'random assortment' means.
- 3 Meiosis is described as a 'reduction division'. **Propose** what this means.
- 4 **Describe** one feature of meiosis that was not shown in this modelling exercise.

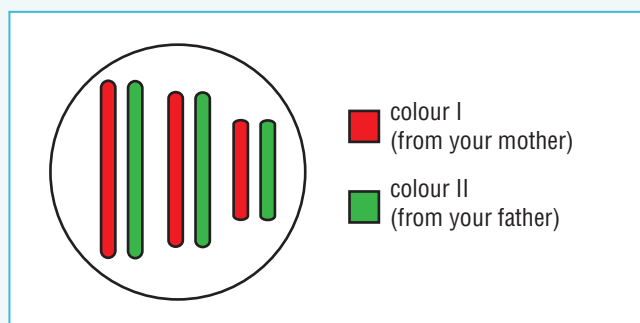

Fig 3.1.15

3 Modelling inheritance

Aim

To model simple inheritance and demonstrate that it is a random process

Equipment

- 60 counters
- beads
- buttons or jelly beans (30 each of two different colours)
- 2 paper bags for each group

Method

- 1 Organise the class into groups. Each group will place 15 counters of each colour in each bag.
- 2 Draw up a table for recording your results, using two letters to represent the colours of the counters, e.g. *R* for red, *G* for green.

<i>RG</i>	<i>RR</i>	<i>GG</i>

- 3 Take one counter from each bag (without looking in the bags).
- 4 The counter from one bag represents the gene from a sperm, the counter from the other bag the gene from an egg cell. Record the genotype of the offspring resulting from your first selection of counters by placing a tick in the appropriate column of the results table.
- 5 Replace the counters and shake the bags.
- 6 Repeat the selection process until 20 results have been obtained.
- 7 Record the totals for each genotype.
- 8 Continue until 100 results have been obtained (or combine results from several groups).

Questions

- 1 The modelling used represents a cross between two heterozygous individuals. **Explain** what 'heterozygous' means.
- 2 **Predict** the pattern for the three genotypes that you would expect to see.
- 3 **State** whether the expected pattern was observed after 20 selections.
- 4 **State** whether the expected pattern was observed after 100 selections.
- 5 **Explain** how the 60 counters would need to be arranged in bags to represent each of the following crosses:
 - a homozygous \times homozygous
 - b homozygous \times heterozygous.

context

At some time in your life you have probably been told that you look like someone else, most probably your immediate blood relatives. Perhaps you have your father's nose, your mother's

eyes or your grandfather's ears. Although everyone is unique, all of us resemble our biological parents and grandparents in some way. Human inheritance follows similar patterns to that shown in peas, rats and cows.



Fig 3.2.1 Your genes come from your mother and father, but you probably look different to them and your brothers and sisters.

Simple human inheritance

Some characteristics in humans are controlled by a single gene. Some of these characteristics are fairly trivial ones, such as the ability to roll your tongue. Others, such as right- or left-handedness, affect everyday life. Some produce severe conditions such as albinism.

The table below shows some of the characteristics controlled by a single gene in humans.



Characteristic	Dominant	Recessive
Tongue rolling	Able to roll tongue	Unable to roll tongue
Right- or left-handed	Right-handed	Left-handed
Hairline	Widows peak present	Straight hairline
Ear lobe attached or free	Attached	Free
Albinism	Normal pigment production	No pigment

Albinism is the inability to make the pigment melanin that normally colours the skin. An **albino** has white hair and pink eyes. Normal colour (*A*) is dominant, while lack of colour (*a*) is recessive. If two people who are heterozygous for albinism have children, then a Punnett square suggests that chances that their offspring will be an albino are one in four or 25 per cent.

Science Clip

White is sometimes fatal

Albinos appear in almost every plant and animal species. Albinism in plants is lethal because the plant cannot make food without the pigment chlorophyll. In animals, it is often fatal because it makes the animal a more obvious target for predators. Albino humans and albino animals also have no protection from the Sun's ultraviolet rays and are more likely to get skin and eye cancer.

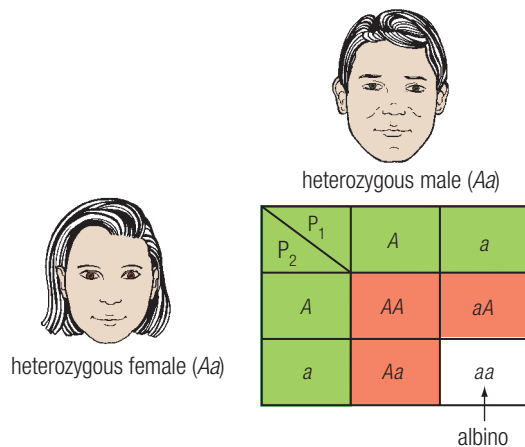

Fig 3.2.2 Albinism is a genetic condition that can only happen when both parents carry the recessive albino gene. Neither of the parents might be albino.

Blood groups

Blood is commonly transfused during operations and in emergencies. The blood group you belong to determines who you can take blood from and who you can donate it to. If the wrong blood group is transfused, then death is highly likely. Genetics determine which blood group you belong to.

While there are several systems of grouping blood, the two commonly used are the Rh and ABO groupings.

Rhesus factor

Rhesus is a type of **antigen**. Blood that contains the Rhesus antigen is classified as Rhesus positive (**Rh positive**). Blood without the Rhesus antigen is classified as Rhesus negative (**Rh negative**). The Rh system is controlled by two alleles. Having the Rhesus antigen (allele R) is dominant over not having it (allele r). A person can be Rh positive (either homozygous RR or heterozygous Rr or rR) or Rh negative (homozygous rr).

A Punnett square shows the combinations that could come about if both parents were heterozygous Rh positive.

P_1	R	r
P_2	R	r
	RR	Rr
	rR	rr



Fig 3.2.3 Blood is grouped according to which antigens it has or doesn't have.

ABO blood types

In the ABO grouping system, type A blood contains antigen A, type B blood contains antigen B and type AB blood contains both. Type O blood is the most common type of blood. It contains neither antigen A or B. This ABO system of blood types involves three different alleles, identified as I^A , I^B and I^O :

- I^A and I^B are codominant
- I^O is recessive to both I^A and I^B .

The possible blood groups of a child can be determined if the blood groups of the parents are known. Alternatively, if the blood groups of mother and child are known, the possible blood groups of the father may be determined.

If, for example, a child has blood group O and its mother has blood group A, then the father cannot possibly have an AB blood group. This is because:

- the only possible genotype of the child is $I^O I^O$
- one I^O gene had to come from the mother, suggesting she has the genotype $I^A I^O$. She cannot possibly be the genotype $I^A I^A$. Although it also gives blood group A, she could not have a child of blood group O with this genotype
- the other I^O gene had to come from the father. This suggests that he is either blood group O (genotype $I^O I^O$), group A ($I^A I^O$) or group B ($I^B I^O$). Therefore, he cannot have an AB blood group.

Other types of human inheritance

While some of your characteristics were inherited in a relatively simple way, the vast majority were not.

Eye colour

In white-skinned people, eye colour is to some extent determined by a single gene. Brown eyes (allele B) are dominant over blue eyes (allele b). This means that:

- genotypes BB or Bb produce brown eyes
- the homozygous genotype bb produce blue eyes.

Green and grey eyes are genetically considered to be forms of blue, while hazel and black are forms of brown. While the basic colour is determined by one pair of alleles, other genes are known to modify their effects.

Genotypes and phenotypes for the ABO blood grouping

Genotype	$I^A I^A$	$I^A I^O$	$I^A I^B$	$I^B I^B$	$I^B I^O$	$I^O I^O$
Phenotype (blood group)	A	A	AB	B	B	O

Science Clip

Young blue eyes

Babies of European descent are normally born with blue eyes. It is only later, after melanin production increases, that blue eyes may change into other colours.



Fig 3.2.4 Eye colour is inherited, with brown eyes dominant over blue eyes.

At present, three genes are known to influence human eye colour. The first gene (on chromosome 15) has a brown and a blue allele, while a second gene (on chromosome 19) has a blue and a green allele. On chromosome 15, there is another gene that is a brown eye colour gene.

Variation

Characteristics that are clearly defined are described as showing **discontinuous variation**. Examples are the colours of pea pods (green or yellow), albinism (albino or not), ear lobe (attached or hanging) or whether a person is left- or right-handed.

Other characteristics such as height, eye, hair and skin colour show **continuous variation** because a range of characteristics may occur. People are not simply tall or short, but show a range of heights. Tall parents seem to produce tall children. This suggests that height is partly inherited, but probably under the influence of several genes. Environmental factors must also play a part. For example, an undernourished child may not grow as tall as their genes might have allowed them to. Likewise, intelligence seems to be partly inherited under the influence of several genes. Environmental influences also affect intelligence. There is a long and ongoing debate about how much of intelligence is inherited (nature) and how much develops and therefore depends on the surrounding circumstances (nurture).



Pedigrees

Compared to other organisms, humans take a long time to breed and only produce a few offspring, making it impossible to study human inheritance in the way Mendel did with his peas. Instead, pedigrees of families are recorded and analysed, especially those families with rare characteristics. A **pedigree** is a family tree where individuals who show a particular disease or characteristic are marked on it. A little detective work can then find patterns of inheritance.

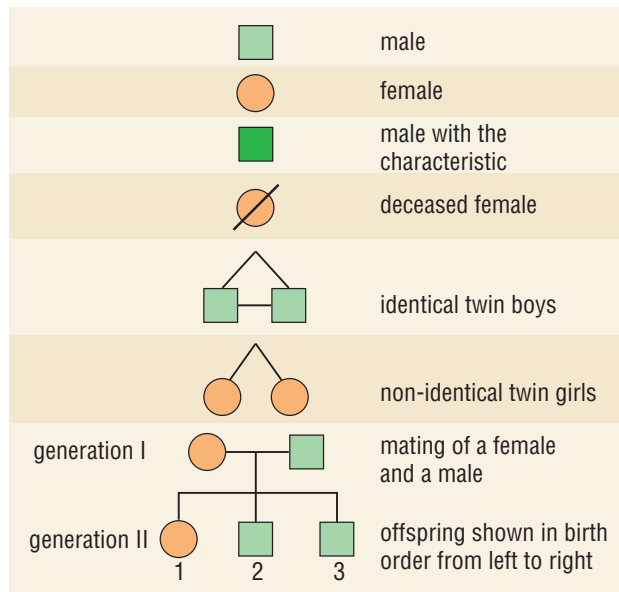

Fig 3.2.5 The symbols used to construct pedigrees



Analysing pedigrees

Pedigrees can show the incidence of a particular genetic characteristic, perhaps a genetic disorder. Careful analysis can show whether the gene causing the characteristic is dominant or recessive.

Worksheet 3.3 Pedigree analysis



Neither the male nor the female parent is affected by the characteristic but their daughter is. This indicates that it is caused by a recessive gene. Both parents 'carry' the gene without being affected by it

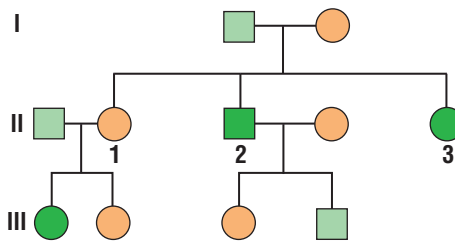

Her aunt is also affected by the characteristic but her grandparents are not. This reinforces the idea that the gene causing the characteristic is recessive

Fig 3.2.6 Analysis of a pedigree can show whether a characteristic is dominant or recessive. In this case, the gene is recessive.

Boy or girl?

A human has 46 chromosomes arranged in 23 pairs. Twenty-two of these pairs have chromosomes of roughly the same size and shape. For pair number 23, however, the chromosomes are either the same or are very different. This set of chromosomes determines whether a child will be male or female. The chromosomes for this pair are known as the X and Y chromosomes. Gender depends on which pairing of these chromosomes the child has:

- males have the genotype XY
- females have the genotype XX.

While all eggs contain an X chromosome, sperm can have either an X or a Y chromosome. In humans, it is the type of sperm (X or Y) from the father that determines the sex of the offspring.



Science Clip

Roughly 50/50

Since there are an equal number of X- and Y-carrying sperm, there should be an equal number of girls and boys born. In most parts of the world, however, there are slightly more boys than girls born. Why is not clear, but the sperm carrying the Y chromosome are lighter and are more likely to reach the egg first, to produce a male. The balance of males and females in the population is later restored, since the mortality rate for boy babies and men is slightly higher than for girl babies and women.

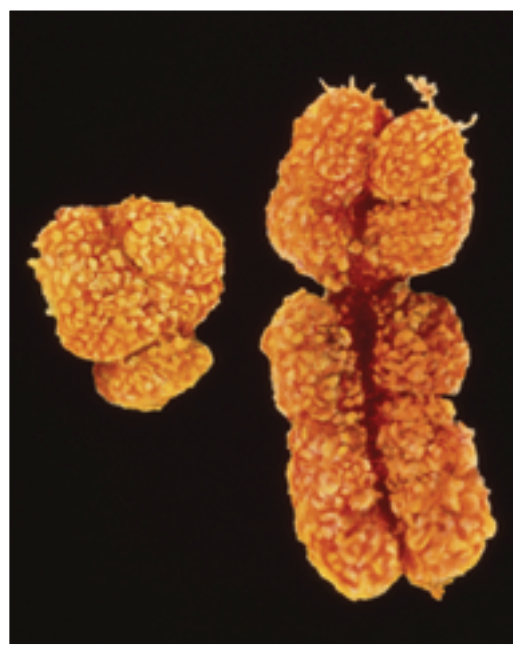

Fig 3.2.7 A coloured scanning electron micrograph (SEM) of a Y (left) chromosome and an X chromosome (right).

Sex-linked disorders

Inherited conditions such as colour blindness, haemophilia and one form of muscular dystrophy are far more common in males than females. Eight per cent of males, for example, are colour blind compared with only one per cent of females. This is because many genetic disorders are **sex-linked** or **X-linked**.

The X chromosome is larger and carries many more genes on it than the Y chromosome. The X chromosome therefore controls many more of an organism's characteristics than the Y chromosome.

Females (XX) have two X chromosomes and therefore have two genes for each characteristic. For these characteristics, inheritance in females follows the rules established earlier: the presence or absence of the dominant gene determines what is inherited.

Males (XY), however, only have one X chromosome. Many characteristics do not have a matching gene on the Y chromosome and they are determined solely by their single X chromosome. Over 50 disorders are caused by recessive genes on the X chromosome.

Science Fact File

Genetics: haemophilia

Sometimes called the 'bleeder's disease', haemophilia is almost always fatal if untreated. Those with the disorder have a defective gene and as a result, lack a particular blood-clotting chemical. Without this chemical, simple cuts bleed uncontrollably. Likewise bruises (caused by ruptured blood vessels underneath the skin) spread uncontrollably.

Haemophilia is a recessive X-linked disease and so affects mostly males. The genotypes can be worked out by using:

- X^H for a normal gene on an X chromosome
- X^h for the recessive gene for haemophilia on an X chromosome.

Most males have the genotype X^HY and do not have haemophilia. Males that have the condition have the genotype X^hY .

Females can carry the recessive gene (heterozygous genotype X^HX^h), but not have the disease. Although they carry the haemophilia gene, it is 'hidden' by the dominant gene. These females are said to be carriers of the disease.



Fig 3.2.8 Extended bruising under the skin caused by the sex-linked 'bleeder's disease' haemophilia

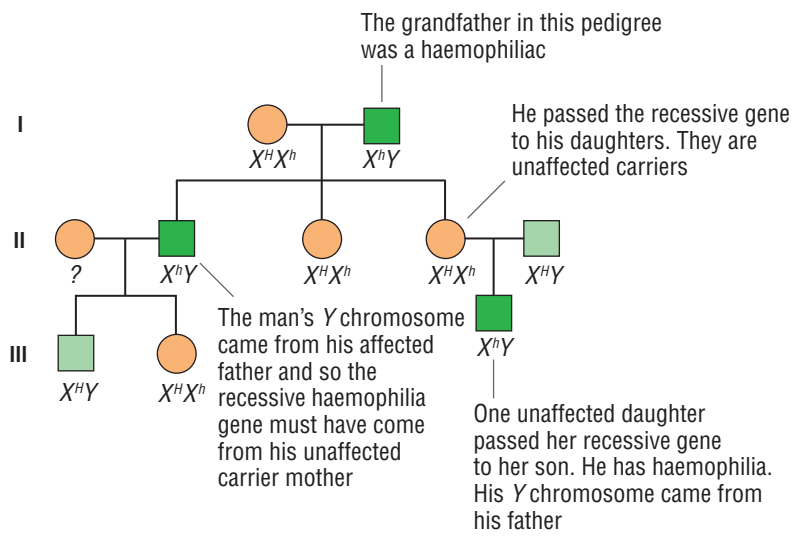

Fig 3.2.9 A pedigree showing the inheritance of haemophilia which is a sex-linked genetic disease. Analysis of the pedigree shows how the defective gene passed from one generation to the next.

Science Clip

A royal disease

The gene for haemophilia has affected history. From her birth in 1819, Queen Victoria was an unknowing carrier. She gave birth to four boys and five girls, one son being haemophiliac. Two carrier daughters went on to have haemophiliac sons and, through marriage, introduced the gene into the Russian and Spanish royal families. The illness of the sole male heir to the Russian throne, Alexis, contributed to the Russian revolution in 1917 and the later execution of the family. The Tsarina, mother of Alexis, thought that a monk named Rasputin had magical powers which could cure Alexis's haemophilia. Because of this, she allowed Rasputin to influence Russia's policies, leading in part to the revolution.



Fig 3.2.10 The 'mad monk' Rasputin

Career Profile

Medical laboratory technician

Medical laboratory technicians carry out routine laboratory tests and other procedures for use in the diagnosis and treatment of diseases and disorders of the human body.

Medical laboratory technicians can be involved in:

- setting up equipment used in the laboratory and maintaining it in a clean condition
- preparing and staining slides of micro-organisms for examination
- testing and analysing blood, tissue or other body samples to determine blood types and composition, and to identify diseases
- analysing DNA samples to screen for diseases
- communicating the results of tests to the medical officers who have requested them.

A good medical laboratory technician will be able to:

- work as part of a team with doctors, scientists and laboratory assistants

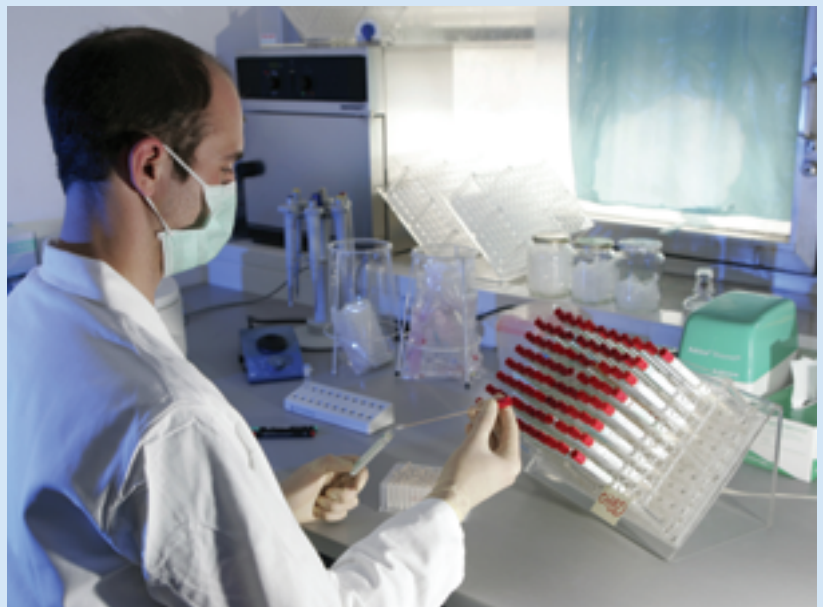

Fig 3.2.11 A medical laboratory technician prepares DNA for analysis

- work accurately and with minimal supervision
- do repetitive work without losing concentration
- keep accurate records and communicate well
- apply scientific method to problems.

3.2 QUESTIONS

Remembering

- 1 List** seven human characteristics inherited through a single gene.
- 2 Draw** a Punnett square to **recall** how haemophilia can arise in children born to healthy parents who show no sign of the disorder.
- 3 State** the genotypes that produce the blood types:
 - a Rh positive
 - b Rh negative
- 4 List** the eye colours that are genetically considered:
 - a blue
 - b brown
- 5 State** an example of a genetic characteristic that shows:
 - a continuous variation
 - b discontinuous variation
- 6 Recall** pedigrees by matching each pedigree symbol below with its correct meaning:





	Symbol	Meaning
a		mating of a male and female
b		male with the inherited characteristic
c		identical twin boys
d		female without the inherited characteristic
e		deceased male

Fig 3.2.12

- 7 State** the genotype of:
 - a a male
 - b a female

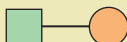
Understanding

- 8 Modify** the following statements to make them correct.
 - a The X chromosome is responsible for female characteristics only.
 - b Males have the genotype XX.

- c The Y chromosome carries more genetic coding than the X chromosome.
 - d Sex-linked diseases occur because the Y chromosome has fewer genes than the X.
 - e Diseases like haemophilia are inherited through males in a family.
- 9 Explain** how two parents can have a child with a genetic disorder, even though they show no outward signs of the disorder themselves.
 - 10 Explain** why a carrier of a genetic disease is not affected by it.
 - 11 Explain** why males are more likely to be affected by genetic diseases and disorders than females.

Applying

- 12 Identify** what blood groups the following genotypes represent:

a $I^A I^A$	b $I^A I^O$
c $I^A I^B$	d $I^B I^B$
e $I^B I^O$	f $I^O I^O$
- 13** A man with blood group B and a woman with blood group A produce a child. **Identify** the possible blood groups of the child.
- 14** A child has blood group AB. The mother has blood group A.
 - a **Identify** the possible blood group genotypes of the father.
 - b **Identify** the possible blood groups of the father.
- 15** Cystic fibrosis is a genetic disorder carried by a single recessive gene. Two unaffected parents have a child who has cystic fibrosis.
 - a **Use** the Punnett square shown in Figure 3.2.13 to determine the chance of them having another child with cystic fibrosis. **N**
 - b **State** the chance of them having another child without the disorder. **N**
 - c The two parents eventually have a family of four children. Three have cystic fibrosis with one unaffected. **Explain** how this can happen.

	P_1	C	C
P_2		C	C
	C	CC	Cc
	c	cC	cc

Fig 3.2.13

Analysing

16 Classify the following characteristics as examples of continuous or discontinuous variation.

height	baldness
ability to roll the tongue	sex or gender
weight	albinism
skin colour	intelligence
blood group	

17 Tongue rolling is a dominant trait controlled by a dominant gene (R) and a recessive gene (r). **Analyse** the pedigree for tongue-rolling shown in Figure 3.2.14.

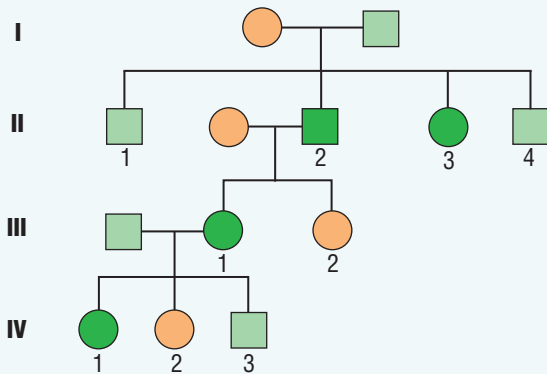

Fig 3.2.14

18 Identify the genotypes of each of these individuals:

- I male (generation I male)
- II 1
- III 1

Evaluating

19 Analyse each of the following and answer the question asked in each. In each case, **justify** your answer.

- Can a male be a carrier of haemophilia?
- Sperm are either male or female. Is this statement correct, incorrect or a bit of both?
- A genetic abnormality occurs where a person has the genotype XXY . Would the person be male or female?

Creating

20 Construct a table or chart showing what blood groups can and cannot be used in patients of different blood groups.

21 The ability to roll the tongue is a dominant characteristic. Two people who cannot roll their tongue have four children.

- Construct** a Punnett square showing all the possible genotypes from these two parents.
- Predict** how many of these children are likely to be able to roll their tongue. **N**

22 Construct Punnett squares to determine the following.

- If two albino people partner and produce a child, what are the chances the child will be albino? **N**
- If an albino person partners a person heterozygous for albinism, what are the chances of their children being albino? **N**

23 Construct a pedigree based on the following information.

Jim and Jean are partners. They have four children, Scott, James, Natasha and Alan. James has a partner, Kylie. They have two children, Susan and Alison. Susan has a partner, Paul. They have three children, Anne, Emma and Colin. James, Natasha, Susan and Anne are all albino.

3.2 INVESTIGATING

Investigate your available resources (for example, textbooks, encyclopaedias, internet) to complete the following tasks.

- Gather information about the pedigree of a champion horse or show dog.
 - Construct a pedigree for your chosen animal.
 - Annotate the pedigree with the factors and outcomes that were important when matings were chosen at each stage of the pedigree.
- Research human blood groups, their genetics and the problems raised by blood transfusions. Present a case study on one problem, explaining how it arose. **L**

e-xploring

To assist with the following activities, a list of web destinations can be found on **Science Focus 4 Second Edition Student Lounge**.

- Research a human genetic disease such as cystic fibrosis or muscular dystrophy. Contact relevant sources for information. Design a website or pamphlet explaining the cause, occurrence and treatment of the disease. **L**
- Follow up activity **1a** on constructing pedigrees, and give a PowerPoint presentation of your resulting pedigree. The tutorial contains instructions on how to do this.



3.2 PRACTICAL ACTIVITIES

1 Dominant or recessive?

Aim

To determine which characteristics are statistically dominant and which are recessive

Method

- 1 Tally how many people in your class have each of the different characteristics shown in Figure 3.2.15.
- 2 Determine which form of each characteristic is most common.

Questions

- 1 List those forms of the eight characteristics you found to be statistically dominant.
- 2 Sometimes the most common form of a characteristic is not the dominant one. Check back to the table on page 92 to **assess** whether the dominant forms listed there are also the most common in your class.

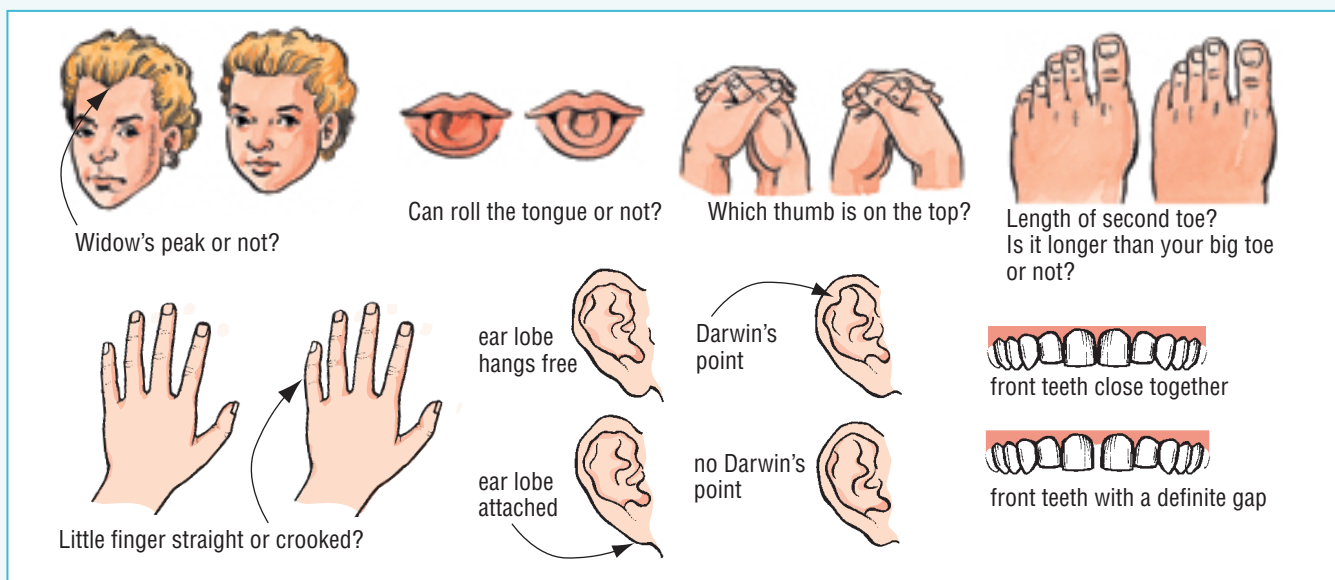

Fig 3.2.15

2 Continuous variation

Aim

To analyse continuous variation in humans

Equipment

- tape measure or metre rulers

Method

- 1 Record the height (in centimetres) of all the students in your science class.

- 2 Calculate the average height of the girls and the average height of the boys.

Questions

- 1 **Assess** whether the results obtained show continuous variation.
- 2 **Propose** reasons why the results obtained are probably not representative of the entire population.
- 3 Boys are taller than girls. **Discuss** this statement based on the results obtained in this Prac.

3 Vegetable babies

Vegetable babies are born either male (potato) or female (onion). The tables below show the sex chromosomes, the phenotypes, their possible genotypes and the dominant and recessive alleles that are responsible for their characteristics.

Aim

To construct different phenotype vegetable babies based on dominant and recessive alleles

Equipment

- potato
- sultanas
- slices of carrot and parsnip
- long and short sticks of celery
- onion
- fresh peas
- toothpicks

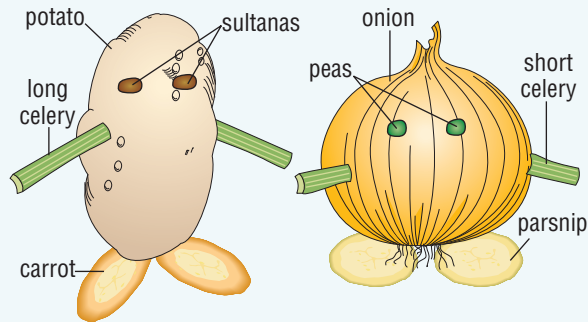

Fig 3.2.16

Method

- 1 Cut or tear up a piece of paper into 16 pieces.
- 2 On eight of them, write the sex chromosomes and alleles for Onion mother, according to the table below. Place them face down in groups (sex, feet, arm, eye).

Parent	Sex chromosomes	Feet genotype	Arm genotype	Eye genotype
Onion mother	XX	ff	AA	ee
Potato father	XY	Ff	aa	Ee

- 3 On the other eight pieces of paper, write the sex chromosomes and alleles for Potato father. Place them face down in groups (sex, feet, arm, eye).
- 4 Randomly select one sex chromosome from Onion mother and one sex chromosome from Potato father. Then randomly select one foot allele, one arm allele and one eye allele from Onion mother and again from Potato father.
- 5 Use the table below to determine the sex of your vegetable baby and its feet, arm and eye phenotypes.

Characteristic	Phenotype	Genotype	Alleles responsible
Feet	Carrot slices	FF or Ff or fF	F (dominant)
	Parsnip slices	ff	f (recessive)
Arms	Short celery stick	AA or Aa or aA	A (dominant)
	Long celery stick	aa	a (recessive)
Eyes	Sultana	EE or Ee or eE	E (dominant)
	Pea	ee	e (recessive)

- 6 Construct your vegetable baby, securing its body parts with toothpicks.

Questions

- 1 **Construct** Punnett squares for the characteristics feet, arms and eyes.
- 2 **Predict** the chance of each different phenotype for each characteristic. **N**
- 3 In this experiment, **state** the probability of having a baby potato.
- 4 **Construct** a table showing how many vegetable babies in the class had each phenotype.
- 5 **Calculate** the percentage actually obtained by the class of each characteristic. **N**
- 6 **Compare** these percentages with those expected. Comment on your results.

context

Each gene is made of a chemical called **deoxyribonucleic acid (DNA)**. The structure and arrangement of atoms in this

amazing molecule determine what the genes instruct the cells of an organism to do and what many of its characteristics will be.

Deoxyribonucleic acid (DNA)

DNA is a long molecule with two strands twisted together to form a **double helix**. Between each strand are cross-links. Its basic structure is similar to a ladder that has been twisted into a spiral. The ladder's uprights are made of a chain of alternating sugar and phosphate units. The ladder's rungs are made of pairs of special molecules called **nitrogen bases**. There are four different nitrogen bases, represented by the letters:

- A = adenine
- T = thymine
- C = cytosine
- G = guanine.

The chemical structure of each base means that it can pair only with one other. The only possible **complementary base pairs** are:

- A pairing with T
- C pairing with G.

For example, if one upright of the ladder (one strand of DNA) has the base sequence of ATTCGTC then the opposite strand would have the complementary

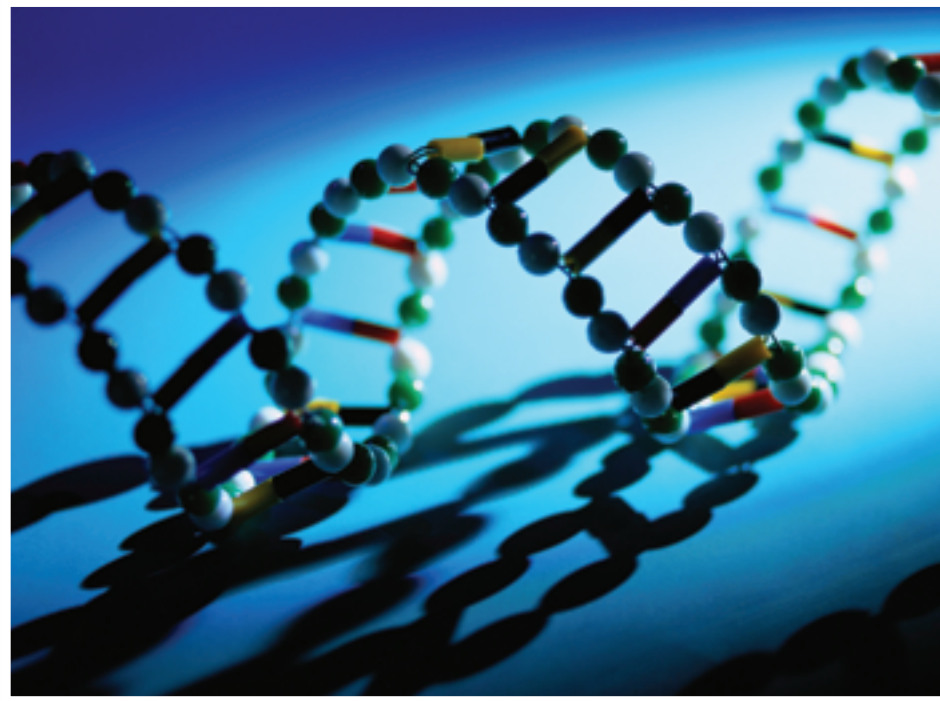

Fig 3.3.1 DNA acts like an instruction manual: it contains all the instructions on how to make an organism and what its cells are to do.

sequence, TAAGCAG. The sequence of these nitrogen bases along the strands of DNA is the basis for all inherited characteristics.

Worksheet 3.4 Model DNA

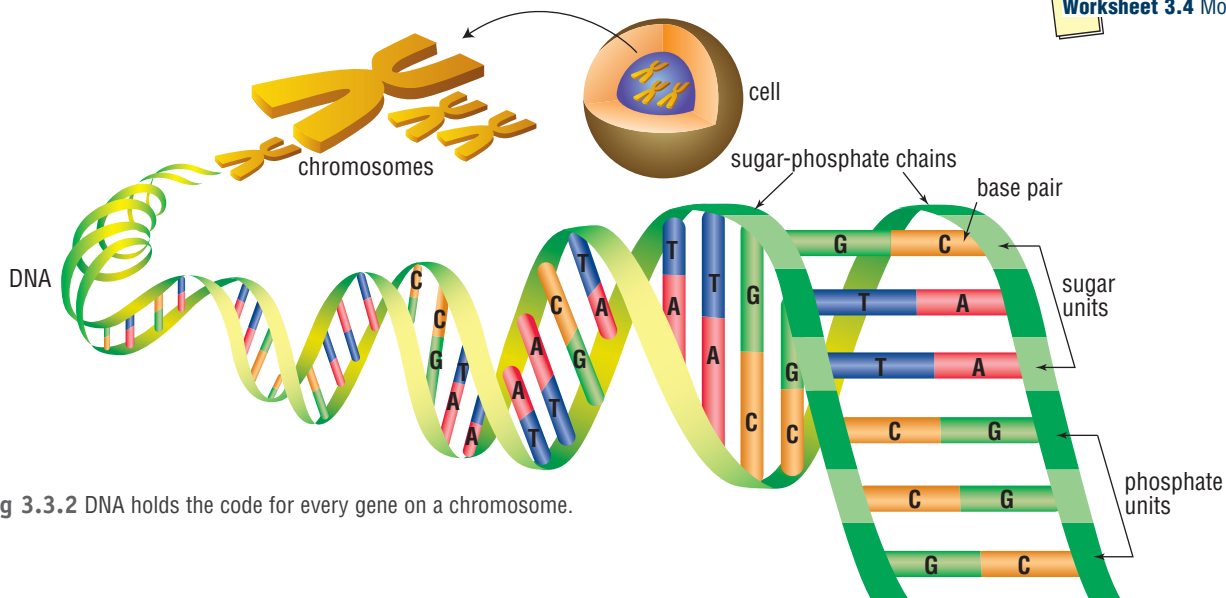

Fig 3.3.2 DNA holds the code for every gene on a chromosome.

Science Clip

That's huge!

In each cell there are 46 chromosomes, 2 metres of DNA, 4 billion nitrogen bases and approximately 32 000 genes!

The Watson-Crick model of DNA

The double-helix structure is known as the Watson-Crick model of DNA after the two scientists who first proposed it in 1953. In 1962, the Nobel Prize for Physiology or Medicine was awarded to the British molecular biologist, physicist and neuroscientist Francis Crick (1916–2004) and American biologist James Watson (born 1928) for their work

on the molecular structure of DNA. The Prize was shared with another molecular biologist, New Zealander Maurice Wilkins (1916–2004), whose findings furthered the understanding of its structure.

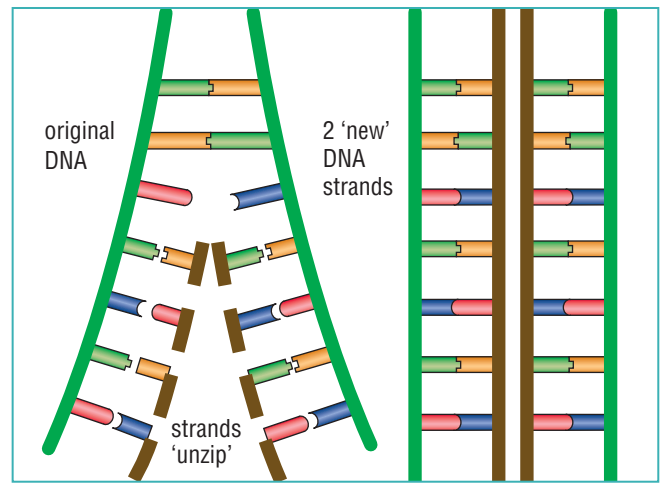
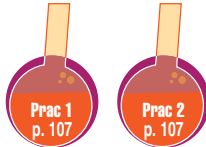

Fig 3.3.4 DNA replicates by unzipping and copying each side.

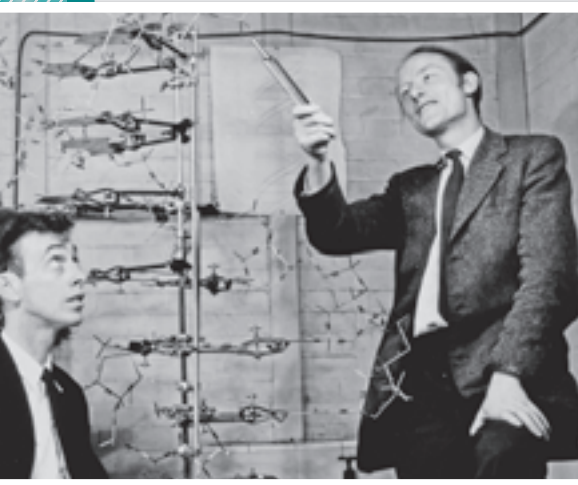

Fig 3.3.3 James Watson and Francis Crick discovered the structure of DNA in 1953. This image shows both scientists with their first model of it.

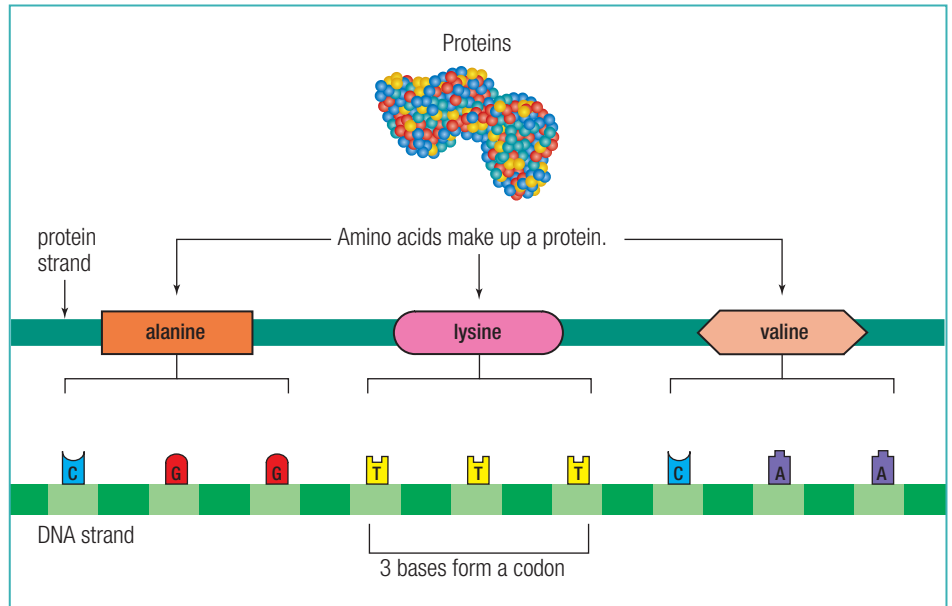

Fig 3.3.5 Different codons form different amino acids. Different sequences of amino acids form different proteins.



How DNA is copied

When a cell reproduces by mitosis, the DNA is copied exactly in a process called **replication**. The strands are first unzipped. An exact copy is then made by matching each base with its complementary base. Once a section is copied, one old and one new strand are zipped together to produce the duplicate DNA.

The genetic code

Up to one thousand bases (or rungs on the DNA ladder) are needed to make up a single gene. The difference between one gene and another is in the order of its bases. This order forms its genetic code:

- sets of three bases form base sequences or **codons**
- each codon contains the instructions to form an **amino acid**. For example, the codon CGG codes for the amino acid alanine, TTT for lysine, CAA for valine, and so on
- cells join amino acids together into chains to make **proteins**
- these proteins determine characteristics such as eye colour.

There are 64 different codons and from these 20 different amino acids are coded for. Different combinations of these 20 amino acids can create thousands of different proteins.

Science Clip

Going ape

The genetic code appears to be universal. The same codon almost always specifies the same amino acid in all organisms. So, if a fruit fly and a human both have the codon TTT, then they both have the same amino acid lysine. The universal nature of the genetic code strongly supports the idea that all living things are related to each other, and have evolved from the same primitive organisms or common ancestors. Comparisons of DNA are used to provide evidence of the relatedness of different species.

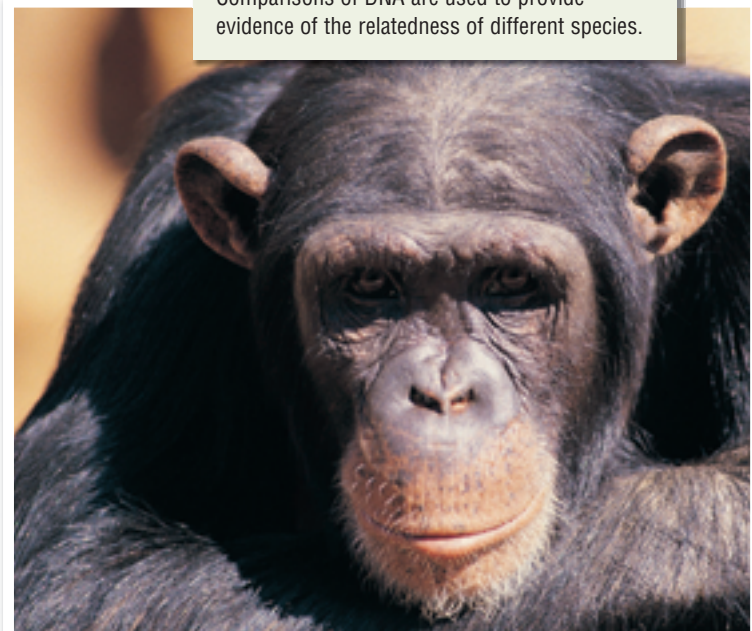

Fig 3.3.6 98.5% of the genetic code for a chimpanzee is identical to that of a human. That means we are only 1.5% different!

Although every gene is present in every cell, not all are active. For example, the gene for haemoglobin production is switched 'off' in the nerve cells in animals. This is because genes also contain information about where and when they are to switch 'on'. When activated, the characteristic they code for appears. This is referred to as **gene expression**. As the body develops and ages, different genes are activated.

Environmental factors

Sometimes environmental factors switch genes on and off. One example is pigment formation in Himalayan rabbits. These rabbits are normally white with black ears, nose, feet and tail. They inherit a gene for an enzyme that is temperature sensitive and is involved in pigment formation. The gene only expresses itself at low temperatures, turning the fur black. When warm, it codes for white fur.

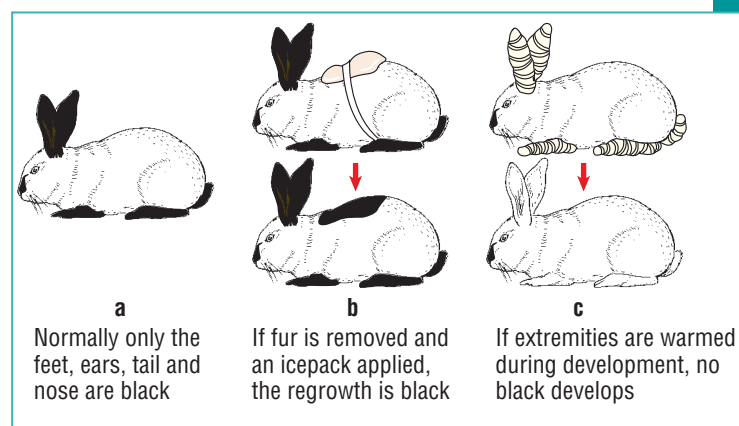

Fig 3.3.7 In Himalayan rabbits, growth of black hair is controlled by a gene. The gene is expressed only at low temperatures.

Determining characteristics

Enzymes are biological catalysts that increase the rate at which chemical reactions take place in the cell. Most proteins are enzymes, and so they control the cell's chemical activities and the characteristics it has.

Gene expression

Every cell in an organism contains the same DNA with exactly the same code. Even so, each cell specialises so that it does a defined job. In a human, for example, some cells grow into muscles, others into nerves, some into blood cells and others into organs such as lungs and brain. Some cells produce hormones such as insulin while others do not.

Mutations

Accidents sometimes occur in the copying of the DNA strands during replication. A **mutation** is any spontaneous change in a gene or chromosome that may produce an alteration in the characteristic for which it codes. Mutations are not inherited unless they occur in the sex cells (sperm or egg cells) or in the zygote which forms on fertilisation.

Mutagens

Mutations occur constantly within a species but at a low rate. This rate is increased by exposure to mutation-causing agents called **mutagens**. X-rays, gamma rays and ultraviolet light are known mutagens that come from exposure to nuclear radiation or excessive exposure to



Fig 3.3.8 Radioactive contaminants from a decommissioned uranium plant still pollute the region in China in which this man lives. He also has 12 toes. Radioactivity is a known mutagen.

medical X-rays or sunlight. Chemicals such as benzene and asbestos are also known mutagens. They cause cell mutations that can go on to become a cancerous tumour.

Single gene mutations

Sometimes a mistake is made in copying a small section of the DNA strand. This gives rise to a mutation that affects only a single gene. The disease **sickle-cell anaemia** is the result of a single gene mutation. It results in distorted haemoglobin and red blood cells

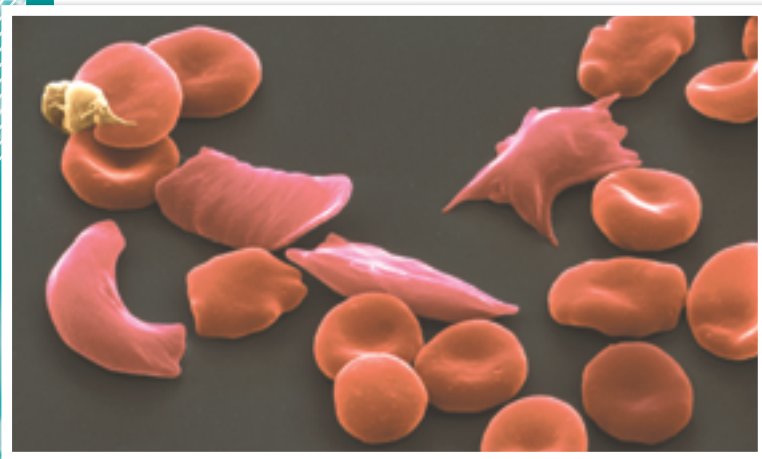

Fig 3.3.9 Normal disc-shaped red blood cells and distorted red blood cells that result from a single gene mutation, causing sickle-cell anaemia

shaped like a sickle. These distorted cells can form clumps and clog small arteries. Victims of the disease usually die young.

Whole chromosome mutations

Mutations may involve whole chromosomes. Parts of chromosomes may break off and rejoin, or whole chromosomes may be lost or added. Sometimes during meiosis, a pair of homologous chromosomes fails to separate. The sperm or egg cell then has an extra chromosome. On fertilisation, there are then three chromosomes instead of two. Many such changes result in spontaneous natural abortion long before birth. One that often doesn't is **Tri-21**,

commonly known as **Down syndrome** in which the person has an extra chromosome on number 21.

[Go to Science Focus 4 Unit 4.5](#)

Good and bad mutations

Mutations can be beneficial, harmful or have no effect on an organism.

New diseases such as bird flu or HIV/AIDS are usually due to mutation of an existing, less harmful disease.

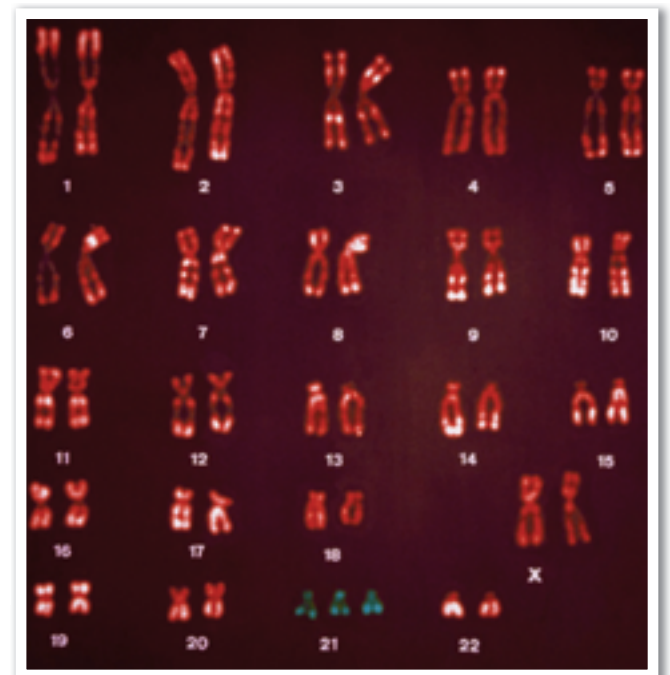

Fig 3.3.10 Chromosomes of a child with Tri-21 or Down syndrome

Other mutations might make a single bacterium naturally resistant to an antibiotic. It will then reproduce and may be difficult to kill, leading to uncontrolled infections. The mutation increases the chance of survival of the virus or bacteria, allowing them to take advantage of new environments in their hosts.

Sometimes a mutation leads to the creation of different species. For example, the Granny Smith apple resulted from a mutation in an apple tree in Sydney. Likewise, navel oranges were a mutation that came from a Brazilian orange tree. Breeders of various species make use of mutations to develop new and improved varieties of organisms such as dogs, cats, horses, sheep and food crops.

Mutations are likely to be responsible for much of the genetic variation seen today. For example, it is possible that all humans once had brown eyes until a blue mutant gene appeared.



Fig 3.3.11 The Granny Smith is the result of genetic mutation.

3.3 QUESTIONS

Remembering

- DNA is likened to a twisted ladder.
 - Name the shape it takes.
 - Specify the two chemicals that make up its uprights.
 - Name the chemicals that make up its rungs.
- State what the letters A, T, C and G in a DNA sequence stand for.
- State the complementary bases for the nitrogen bases:
 - G
 - T
- The twisted-helix model of DNA is named after two scientists. Name them and the scientist with whom they shared the Nobel Prize.
- Specify how much of a human's genetic make-up is the same as that of a chimpanzee.
- Mutations are usually harmful. Specify an example of a beneficial mutation.
- Name a disorder that is caused:
 - by a single gene mutation
 - by having one extra chromosome

Understanding

- Define the terms:
 - codon
 - mutation
 - mutagen

- Explain what a codon is and what it forms.
- Modify the following list, so that it is in order from smallest to largest:
 - nitrogen base
 - DNA strand
 - cell
 - codon
- Explain what is meant by the term *gene expression*.
- A mutation in a skin cell might cause skin cancer but will not be passed onto the next generation. Explain why.
- Use a diagram to demonstrate how DNA is a code for constructing a protein.
- Mutations in a body cell are important to the animal they belong to but are unimportant for the species as a whole. Explain why.

Applying

- Identify a mutagen that may cause a cancerous tumour.
- A base sequence in a particular DNA strand is CGGATAAGCTA.
 - Specify what its complementary base sequence would be.
 - Modify the base sequence by introducing a single mutation into this complementary base sequence.
 - Identify what this single mutation does to the chemicals it codes for.

Analysis

- 17 Calculate** the minimum number of bases required to code for a protein that has 200 amino acids. **N**
- 18** Figure 3.3.10 shows the genes of a child with Down syndrome.
- a Identify** the chromosome on which the abnormality is found.
- b Identify** the sex of the child.

Evaluating

- 19** Excessive exposure to UV radiation from sunlight changes your skin. **Propose** how.
- 20 Propose** reasons why DNA must replicate and what would happen if it did not.

Creating

- 21 Construct** a diagram to show how DNA replicates.

3.3 INVESTIGATING

Investigate your available resources (for example, textbooks, encyclopaedias, internet) to complete the following tasks.

- Write short biographies for J. Watson, M. Wilkins and F. Crick, the scientists awarded the 1962 Nobel Prize for medicine for their work in creating a model of DNA. In particular, outline the contribution of these scientists to the understanding of genetics. **L**
- Research the contribution made by Rosalind Franklin to the discovery of the model of DNA. Write a short biography, including the difficulties she encountered as a female in a male-dominated field. **L**
- Research human genetic abnormalities that involve having the wrong number of chromosomes. Write a report on the types, symptoms, occurrence and treatment of the abnormalities for one disease. **L**

- Research gene switching and gene expression. You could start by considering the work of F Jacob, J Monod and H Harris. Summarise your findings using a timeline. **N**
- Research mutagens and use one example to summarise your findings while answering the following questions.
 - What are they?
 - Can we avoid them?
 - Do regulations exist to limit our exposure to mutagens?

e-xploring

To visit the DNA Extraction Virtual Lab, a list of web destinations can be found on **Science Focus 4 Second Edition Student Lounge**. Perform a cheek swab and extract DNA from human cells.



3.3 PRACTICAL ACTIVITIES

1 Modelling DNA

Aim

To construct a model of DNA



Method

- 1 Design** your own version of the Watson-Crick model of DNA. You might use cardboard for the 'uprights' and coloured paperclips for complementary bases. You might use construction blocks or polystyrene pieces. Liquorice, jelly beans and skewers make a very tasty model! Use your imagination!
- 2** Your model should show all the basic features of DNA.

2 Extracting DNA

Aim

To extract a DNA sample from wheatgerm



Safety

Ethanol is highly flammable and should be kept clear from naked flames (matches, Bunsen burners) and the hotplates themselves.

Equipment

- 250 mL beaker
- 15 mL test tube
- test-tube rack
- measuring cylinders (10 mL and 100 mL)
- meat tenderiser
- non-roasted fresh wheatgerm
- ice-cold 95% ethanol
- thermometer
- glass stirring rod
- dishwashing detergent
- water bath
- compound microscope

Method

Note: To get good strands of DNA it is essential to be very gentle while stirring!

- 1** Add 100 mL of water to a beaker and warm to 50–60°C in a water bath.
- 2** Add one heaped tablespoon (6 grams) of wheatgerm and mix.
- 3** Add 3 mL of detergent to break down the cell membranes of the wheatgerm. Maintain the temperature at 50–60°C and stir for 5 minutes. Be careful not to form froth or scrape the sides of the beaker.

- 4** Add one level teaspoon (3 grams) of meat tenderiser.
- 5** Maintain the temperature at 50–60°C and stir for 10 minutes.
- 6** Remove the beaker from the water bath, and transfer some of your solution from the beaker to fill one-third of a test tube.
- 7** Allow the test tube to cool to room temperature.
- 8** The DNA is still dissolved in solution. Pour 6 mL of ice-cold ethanol down the side of the test tube into your solution to form a layer. The DNA will precipitate into the alcohol.
- 9** Let the mixture stand until it stops bubbling (2 or 3 minutes).
- 10** The DNA will float in the alcohol. Swirl a glass stirring rod at the junction between the layers to see strands of DNA.
- 11** Drag some DNA strands out of the test tube and view under a microscope.

Expected results

You can expect three basic results from your DNA extraction. The actual result will depend on how careful you have been:

- no DNA means something went wrong—revise your method
- fluffy-looking DNA—this means that it has been broken into many small pieces during extraction and is usually caused by rough stirring
- thin threads of DNA—perfect!

Extension

Try extracting DNA from another plant such as strawberries.

Questions

- 1 Describe** your DNA after extraction.
- 2 Explain** why each of the following chemicals was added during the process:
 - a detergent
 - b alcohol
- 3 Deduce** what factors affected your success in extracting DNA.

context



Go to  Science Focus 4 Unit 8.5

Selective breeding

For thousands of years, farmers have carried out **selective breeding** to improve the quality of their herds or crops. Merino sheep, for example, produce more and better quality wool than the breeds from which they originally came. Australian wheat was once attacked by a fungal rust disease. Disease resistance, and a higher yield, came about when wild rust-resistant relatives of wheat were crossed with wheat plants that produced more seed than normal.

Keeping the seeds from only the best plants for next year's crop is a simple example of selective breeding. Other examples are the selective breeding of tomatoes that stay ripe longer, dairy cattle that produce more milk, beef cattle with more meat, pigs with less fat and rice that produces more seeds.

Sometimes variation is produced by deliberately introducing mutations into a population and then selecting those individuals with desirable characteristics. For instance, nectarines are a mutant form of peach.

Farmers have always controlled the genetics and inheritance of their plants and animals by selectively breeding those with desirable characteristics. Over the last 10 years, however, scientists have been actively improving the characteristics of plants and animals by swapping genes between them.

Fig 3.4.1 A digitally manipulated impression of what the future may bring. Genetic modifications in food can radically affect its size, disease resistance and flavour. Many, however, believe that food should not be altered in this way.

Using gene technology to improve an organism

Genetic engineering and **gene technology** manipulate DNA to change the genes within an organism.

Why change genes?

Gene technology allows scientists to isolate a specific gene, alter it, copy it and then reinsert it into a new position. This could be back into the original organism or in a completely different one.

Gene technology has led to:

- larger harvests
- plants with greater disease resistance
- crops with improved storage and handling properties
- fruit and vegetables that last longer and taste better.

Organisms that have their gene sequence altered are called **genetically modified (GM)** plants or animals.

Genetically modified cotton, for example, has a gene from a naturally occurring bacterium, *Bacillus thuringiensis* (Bt) inserted into it. This insertion produces a protein that kills the major pest of cotton (the *Heliothis* caterpillar) when it eats the cotton leaves. The modified cotton is called Bt cotton. Australians currently use a number of products from genetically modified crops in their foods. These include canola oil, soy beans in some soy-based products and potatoes in processed snack foods.



Fig 3.4.2 You may already be eating some genetically modified foods. Current legislation does not require food manufacturers to state on their labels that GM ingredients have been used.

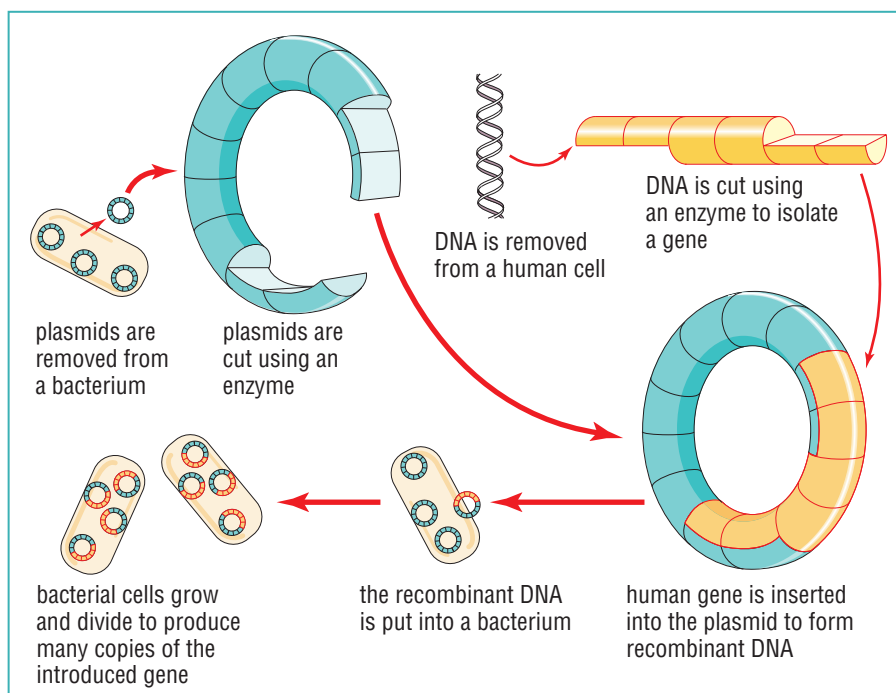

Fig 3.4.3 Enzymes are used to cut and rejoin DNA. Bacteria are then used as 'factories' to copy the new DNA formed.

In the future, genetic modification may have other benefits such as:

- producing plants that can reverse the effects of salinity
- creating bio-fuel bacteria that can produce energy
- producing bacteria that can clean up oil spills and process industrial waste
- allowing genetic diseases to be eliminated.

How gene technology works

Genetic engineering and gene technology alter particular characteristics of an organism by manipulating its genes. To do this, the long strand of the DNA molecule needs to be cut and rejoined.

Using enzymes

Naturally occurring enzymes recognise particular base sequences and use them as markers to cut DNA strands into segments. These segments can be interchanged with segments of DNA from other organisms and then re-joined using different enzymes.

The process is similar to the way a film editor cuts and splices lengths of film to make a movie.

Using bacteria

DNA can be inserted into bacteria using **plasmids**, which are circular pieces of DNA that occur naturally in bacterial cells. An enzyme cuts open a plasmid, the foreign DNA is inserted, and the plasmid is then



Fig 3.4.4 A technician checking a sample of recombinant DNA hepatitis B vaccine

rejoined to form a mixed molecule called **recombinant DNA**. The altered plasmids are then put back into bacteria. On reproduction, these bacteria quickly produce multiple copies of the 'foreign' DNA that was spliced into them. The bacteria act differently because they now obey the instructions of the inserted DNA and manufacture the proteins it codes for.

Nearly all the insulin used by diabetics in Australia is now made in this way. Other substances produced using this kind of technology include the human growth hormone, some antibiotics, and vaccines against diseases such as hepatitis B.

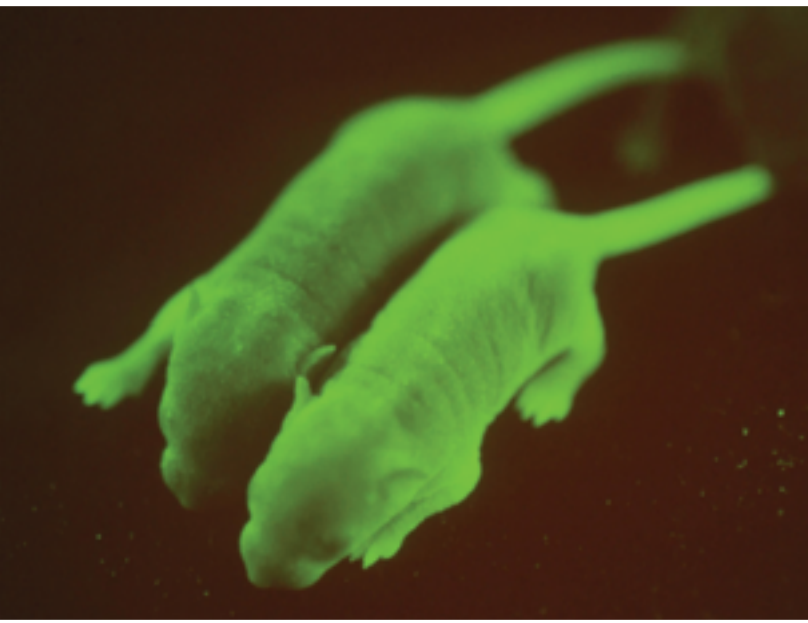

Fig 3.4.5 These fluorescent green transgenic mice have a jellyfish gene inserted into them that codes for GFP, a green fluorescent protein.

Transgenics

Modified genes can be inserted directly into plant and animal cells. In animals, the gene is inserted into the fertilised cell from which all the animal's cells will develop. In plants, the gene may be 'shot' into host cells using a miniature gun. The plant or animal hosting the new gene is said to be **transgenic**.

Using gene technology for testing

Prenatal testing

Prenatal testing can identify genetic defects or diseases before a baby is born. Prenatal testing is carried out using gene probes with a small piece of DNA with a base sequence identical to that of a gene associated with a genetic disorder. The probe sticks to the abnormal gene allowing embryos to be tested for disorders like sickle-cell anaemia or cystic fibrosis.

Forensic analysis

Gene probes are also used in **DNA fingerprinting** in criminal cases such as physical or sexual assault and in civil cases to determine the biological father of children. DNA fingerprinting relies on the fact that everyone has a unique sequence of bases in their DNA found in every cell of their body (the only exception is in identical twins). A suspect's DNA fingerprint can be compared to

the amniotic fluid is a fluid that cushions the foetus and contains cells that 'fall off' the foetus

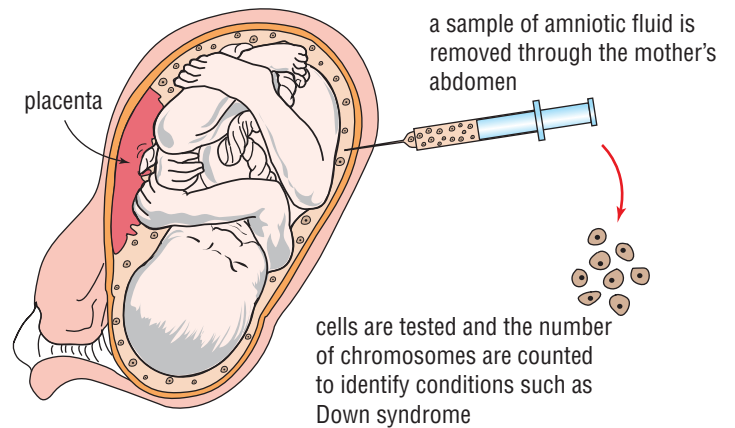

Fig 3.4.6 Amniocentesis: prenatal testing is usually carried out in the first eight to 12 weeks of pregnancy.

the DNA fingerprints obtained from any body fluids (such as blood and sperm), fragments of skin or strands of hair found at a crime scene. DNA fingerprints can then be used in court to prove innocence (no DNA match) or guilt (DNA match).

Using gene technology for cloning

Cloned animals

To produce offspring, animals require a sperm to fertilise an egg cell. This is because each gamete has only half the chromosomes needed. Every other body cell,



Fig 3.4.7 Sheep, cats, insects, and dogs have all been cloned and there have even been claims of illegally cloned humans.

however, has the full quota of chromosomes. **Cloning** is the process in which a single cell is grown to produce a new individual. New animals can therefore be produced without the need for fertilisation.

Therapeutic cloning

It is hoped that therapeutic cloning will soon help repair spinal cord damage, grow skin for burns victims and replace muscle cell damaged in a heart attack.

Therapeutic cloning takes cells from a patient to extract their DNA. The cells are then cloned by inserting the DNA into an egg. The egg grows and after a few days **stem cells** are removed from the egg. Stem cells are special in that they have the ability to grow into any type of cell in the body. The cells can then be placed back into the patient to form the exact cells required to repair the damaged tissue. Stem cells have the same DNA as the rest of the cells in the body and so will not be rejected by them. It is possible that scientists in the future will be able to grow whole organs for transplant this way.

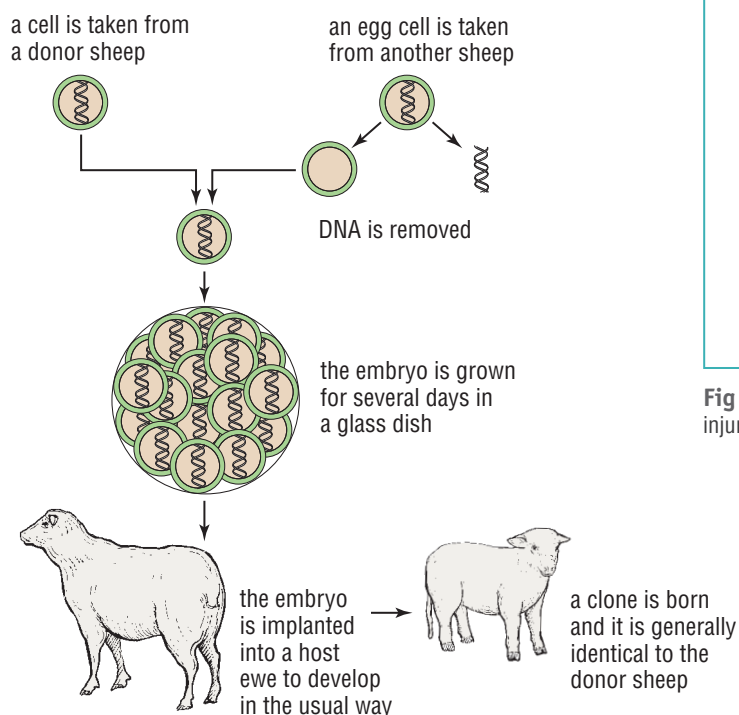

Fig 3.4.8 Steps in the production of a cloned sheep

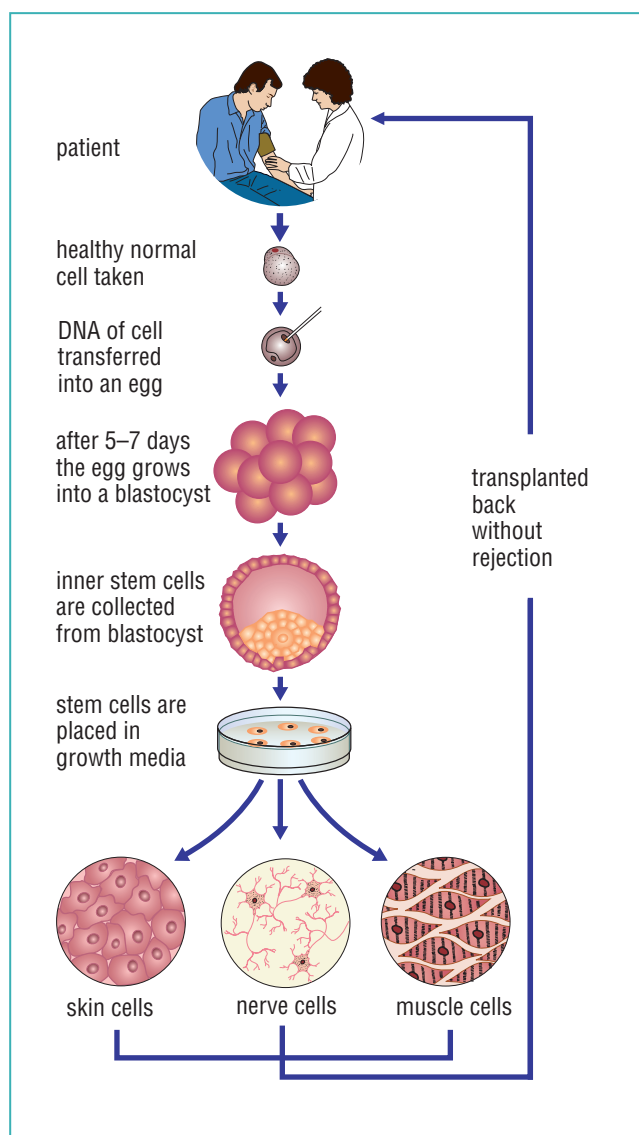

Fig 3.4.9 Therapeutic cloning offers a potential cure to many injuries and diseases.

Gene cell therapy

Gene cell therapy involves removing the genetic material from some body cells, manipulating it and reinserting it into the same person. In the future, gene cell therapy could overcome diseases such as cancer, where the cancer-causing mutation is repaired. Gene cell therapy may also be able to alter the DNA passed from parent to child to prevent the inheritance of diseases such as haemophilia.

Worksheet 3.5 Genetic modification

Are there risks?

All new technologies have benefits and risks. Gene technology is no exception. There are many issues surrounding the use of gene technology, as people weigh the potential benefits against the potential risks. The table below shows a few of the arguments for and against the use of gene technology.

Some arguments against gene technology	Some arguments for gene technology
<ul style="list-style-type: none"> • Genetic modification is not natural. Interfering with a highly evolved and delicate system may upset it in unpredictable ways. • GM plants with inbuilt pesticides may kill insects that are not pests. • Pests will, in time, develop resistance to the inbuilt pesticides in GM plants. • GM herbicide-resistant plants may transfer their resistance to other plants, creating 'superweeds'. • GM herbicide-resistant plants may encourage the excessive use of herbicides. • GM crops will not necessarily solve the world's food problems. Food shortages have more to do with economics and politics than with agriculture. • Multinational companies own the rights to most GM plants. Farmers will incur costs to use the modified plants. • Some religious groups have specific arguments against the use of GM foods. 	<ul style="list-style-type: none"> • Gene technology is faster and more efficient than conventional selective breeding techniques. • Food production will be increased due to better disease prevention and drought resistance in plants. • Animals will produce leaner meat, thicker wool and have increased productivity. • GM foods may be more nutritious, cheaper and keep better than conventional foods. • GM crops with pest resistance will reduce the use of harmful chemical pesticides. • GM crops may be produced that tolerate poor soils and salinity, allowing more areas to be farmed. • Gene technology can be used to locate and study genes causing human disease, and genes that predispose people to other diseases. • Gene technology can be used to create new, improved medical treatments, such as insulin.

Human genome

Gene technology relies on knowing where specific genes are and what they do. A **genetic map** shows the positions of specific genes along the chromosomes. Maps have been developed for many organisms such as bacteria, fruit fly, some fungi and corn. In 2003, the **human genome project** completed mapping the entire genetic code for humans. The project came up with some surprising results:

- 99.9 per cent of the genetic code for all humans is exactly the same
- only six per cent of the DNA in a person's genetic code actually codes for genes. The rest is termed 'junk DNA'
- the genetic map contains 32 000 genes, far fewer than the 100 000 expected before the project
- the code specifies 26 000 proteins.

There is still a great deal to be learned. Armed with the map, many trials are now underway to attempt to use gene technology to cure diseases ranging from haemophilia to cancer.

Science Clip

Getting all sheepish

Expensive prize sheep have finer wool and are healthier and naturally more disease-resistant. By taking cells from these sheep a flock of clones can be produced in a single generation. The egg cells can come from cheaper, 'inferior' sheep and the cloned embryos can be implanted into them as well. The alternative is to selectively breed an improved flock, a process which takes many years.

A lamb called Dolly was born in Scotland in 1997. She was the first successful clone of an adult animal and was genetically identical to her mother. Australia's first cloned merino sheep (Matilda) and first cloned calf (Suzi) were born in 2000. Both were produced using techniques similar to those used to produce Dolly.

Science Clip

Living longer

Francis Collins, head of the human genome project, has stated that by 2030 the genes involved in the ageing process will be fully catalogued. By 2040, gene therapy and gene-based designer drugs will be available for most diseases, and the average human life span is then expected to be 90 years.

3.4 QUESTIONS

Remembering

- 1 **List** two examples of selective breeding.
- 2 **State** the advantage of Bt cotton over 'normal' cotton.
- 3 **State** what is used to slice and re-join DNA.
- 4 **Name** two disorders that can be detected through prenatal testing.
- 5 **State** two examples of how gene technology has been used to benefit humans.
- 6 Referring to the human genome project, **state**:
 - a what percentage of the genetic code was found to be the same
 - b how many genes were found
 - c how many proteins were found

Understanding

- 7 **Use** examples to explain what the following terms mean:
 - a gene technology
 - b genetically modified plant
 - c transgenic animal
- 8 **Describe**:
 - a where plasmids are found
 - b how plasmids are used in gene technology
- 9 **a Explain** what is meant by a 'gene probe'.
b Outline two uses of gene probes.
- 10 DNA fingerprinting always gives the same results, regardless of whether the sample comes from someone's blood, skin or hair. **Explain** why.

Applying

- 11 **Identify** one animal and one crop that were improved through selective breeding.
- 12 **Discuss** whether cloning and therapeutic cloning in humans is ethical.

Analysing

- 13 **Distinguish** between cloning and therapeutic cloning.

Evaluating

- 14 In a heart transplant, a heart built from stem cells is better than one that is donated. **Propose** reasons why.
- 15 Imagine a person's genetic code was mapped and a gene predisposing that person to heart disease was identified.
 - a **Propose** ways in which the person might use this information.
 - b **Propose** ways in which an insurance company or a prospective employer might use this information.
 - c **Discuss** whether this sort of information should be made available to people other than the person it was taken from.
- 16 **a Explain** what gene cell therapy is.
b Propose two possible uses of gene cell therapy.
- 17 Bt cotton produces a protein that kills its major pest, the *Heliothis* caterpillar. **Propose** two suggestions of how it might affect organisms other than *Heliothis*.
- 18 To decide whether it should continue to be investigated, **evaluate** the arguments for and against genetic engineering that are presented in this unit.

Creating

- 19 A genetically modified soybean that can tolerate a commonly used weedkiller has been produced. Using this soybean would allow farmers to spray and kill weeds without killing the soybean crop. It is proposed that this soybean be planted in Australia. **Construct** arguments supporting the planting and arguments against it. **Evaluate** all the arguments you have come up with, decide on which position you will take, and then write a letter or email explaining your views. 
- 20 An experiment is being conducted to genetically modify cow's milk so that it has a composition more like that of human breast milk. To achieve this, a single human gene is to be inserted into the DNA of a cow's zygote (the first cell of a new cow). Imagine you are the human gene.
 - a **Construct** a flow chart or series of dot points describing what happens to you during the course of the experiment.
 - b **Propose** reasons why people might object to the use of human genes in this way.

3.4 INVESTIGATING

Investigate your available resources (for example, textbooks, encyclopaedias, internet) to complete the following tasks.

- 1 Write a short biography of John Macarthur (1767–1834) who improved the quality of Australian wool and William James Farrar (1845–1906) who developed rust-resistant wheat. In your biographies, outline the advantages of the new-improved wool and wheat and how they achieved this improvement.
- 2 Research efforts into 're-creating' extinct animals such as mammoths, the thylacine (Tasmanian tiger) and even dinosaurs using preserved DNA and cloning. Present arguments for and against the 're-creation' and use a flow chart to outline how it might be done.
- 3 Research the use of DNA fingerprinting in criminal cases or in cases involving disputes over who is the father of a particular child.
 - a Present the findings of one example illustrating the DNA fingerprinting.
 - b Discuss whether the findings are foolproof.
- 4 Research arguments for and against the use of prenatal testing and early abortion for family planning. Organise a class debate on the issue.
- 5 Stem cells can theoretically turn into any of the many cell types that make up your body.
 - a Research why stem cells are of great interest to scientists, and why their use is controversial.
 - b Write a newspaper article aimed at informing the public about this issue. 

Reviewing *GATTACA*

GATTACA is a science-fiction film set in the near future. In this future world the job you have is based on your genetics. Watch the movie and prepare a film review about it. In your review you must:

- give details about its length, leading actors, director, producer, studio and year of production
- offer the views of different people in the film
- include how you value each of these people
- state how a person's genetics are tested
- explain how the main character effectively avoids genetic testing

- explain how the person's genetics are used as a form of discrimination
- explain why genetics are used to determine job placement
- offer your point of view about whether this discrimination is right or wrong
- explain what happened in the end
- explain what the title *GATTACA* refers to and why it is relevant to the film
- assess how realistic the film is
- assess how accurate the science is in the film.

Present your review in one of the following ways: 

- an interview with the director, leading actor or the biologist advising the director
- a segment for a TV program such as *ET*, *At the Movies* or *The Movie Show*
- a single page spread for an entertainment magazine or for a movie guide such as *TV Week*.

e-xploring



To assist with the following activities about genetics, a list of web destinations can be found on **Science Focus 4 Second Edition Student Lounge**.

- 1 Research the Human Genome Project and summarise your information under the following headings:
 - What is it?
 - Goals
 - Progress
 - History
 - Benefits
 - Ethical issues
- 2 Imagine that a multinational company owns the patent on a genetically modified variety of wheat that is high-yielding and drought-tolerant. Research ways in which this patent could affect an Australian wheat farmer. Outline the main issues in a letter written to the farmer's local Member of Parliament. 

Prescribed focus area

Current issues in research and development

Biotechnology

Biotechnology is the use of:

- living organisms
- substances produced by living organisms
- biological techniques.

Biotechnology products include antibiotics, insulin, interferon, and recombinant DNA. Biotechnologies include waste recycling, bio-batteries and DNA fingerprinting.

Humans have already exploited biotechnologies in many ways. Plants and animals have been selectively bred and chemicals have been extracted from animals and plants to make medicines, glues, health products and fibres. Scientists now have the ability to determine the genetic code of any organism and manipulate their genes. This ability has triggered the development of many new techniques.

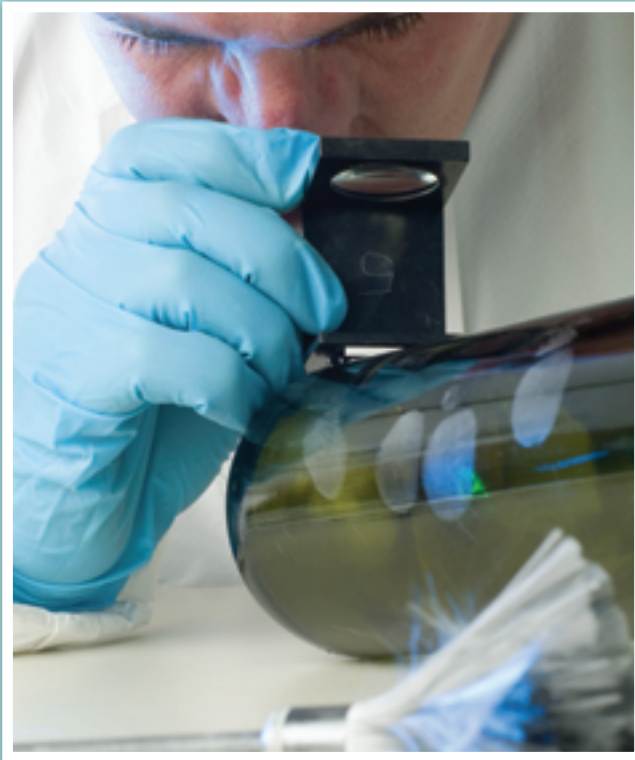

Fig 3.4.10 Although fingerprints allow easy identification, they can also be easily wiped away from a crime scene. Small traces of DNA, however, will always be left behind.

Biotechnology and crime

Police and forensic scientists have always sought a 'universal identifier' that could be used to accurately identify the perpetrator of a crime. Although fingerprints were originally thought to have provided the answer, criminals soon learned to wear gloves or simply wiped clean any surface they touched. The discovery of DNA and its characteristic genetic code provided the 'universal identifier' that forensic scientists had dreamed of. The DNA within your cells is unique. It cannot belong to anyone else. A person can leave DNA on anything they touch by losing a hair or dead skin cells. This makes it almost certain that a criminal will leave some evidence behind.

DNA fingerprinting

Some key biotechnologies are used in the DNA fingerprinting process.

Restriction enzymes

Restriction enzymes are protein molecules that can bind to a particular sequence of base pairs in a DNA molecule and then cut the DNA into sections.



Fig 3.4.11 This technician is placing DNA samples into the wells at the end of the electrophoresis gel ready for separation. The result will be a DNA fingerprint.

Electrophoresis

After cutting the DNA molecule into smaller pieces, scientists need to be able to separate these pieces of DNA for analysis. The process for separating DNA is called **electrophoresis** and is similar to **chromatography**. The DNA samples are placed in a gel and an electric current is applied. The current makes the pieces of DNA move: larger pieces move slowly through the gel and smaller pieces move faster. Pieces of DNA separate across the gel according to their size.

Gene probes

There is a huge amount of DNA in a human cell and much of this genetic material is very similar in different people. To use DNA for solving crimes it is necessary to find sections of the DNA that represent genes that produce different but comparable results for different people. For example, the gene for a physical trait such as hair or eye colour can be used.

Once these genes are identified, a way to mark them while analysing DNA is needed. This is where a **gene probe** is used. A gene probe is a small piece of DNA with a base sequence identical to part of a gene. This enables it to stick to a specific gene. By attaching a radioactive atom (radioisotope) to the gene probe, the radiation released will indicate where the gene probe is attached.

Gene probes that attach to the sections of DNA required for analysis enable forensic scientists to use the information provided by leftover hair, skin, blood or other body fluids.

PCR

Only very small amounts of DNA are needed to conduct DNA fingerprinting. The DNA required can even be obtained from a corpse or a sample where the DNA may have started to break down. If only a very small amount of DNA is available for analysis then a technique called **polymerase chain reaction (PCR)** is used. In this technique, enzymes copy the DNA sample many times, producing more identical DNA. The sample can undergo DNA fingerprinting when enough DNA has been produced.

Science Clip

How successful is DNA matching?

DNA matching has different success rates depending on which sample it comes from. Reported figures are:

- blood—90 per cent success
- saliva on a cigarette butt—67 per cent
- fallen hair—25 per cent.

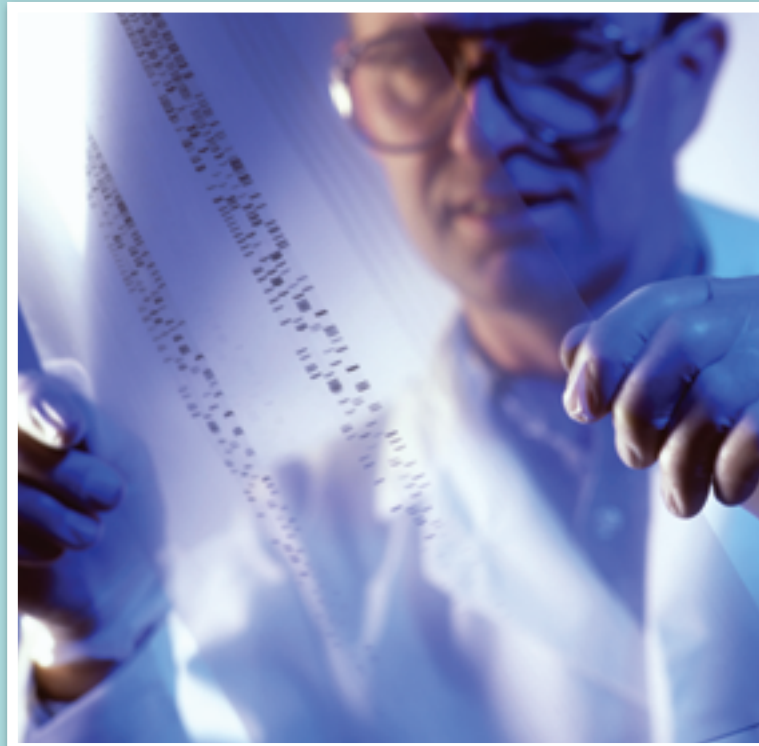

Fig 3.4.12 DNA fingerprints on X-ray film

Using DNA fingerprinting

Crime scene investigation

DNA fingerprinting produces a barcode-type result that is unique to each individual. By comparing the DNA found at a crime scene with that of a suspect, the perpetrator of a crime can be identified.

Paternity disputes

DNA fingerprinting is often used in legal cases where the identity of a child's father might be in doubt. A comparison of the DNA fingerprints of the child, its mother and different men can indicate who is the child's biological father. Since everyone's DNA is so characteristic, a clear match will clearly indicate who is the father. Likewise, a mismatch will show who is not the father.

Other uses

DNA is a very stable molecule. Under the right conditions and in certain tissues it can remain intact for a very long time. For example, DNA in bones or hair can remain intact for hundreds of years. Archaeologists and anthropologists can therefore analyse samples of DNA extracted from ancient corpses, such as Egyptian mummies. The results obtained in these studies are providing information about the relationships between the different races of humans, and about human evolution.

1 DNA is extracted from blood or a cell sample.

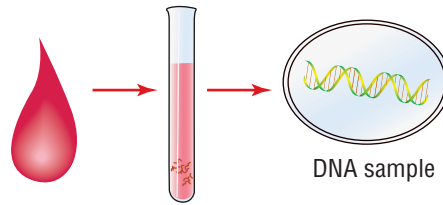

2 DNA is cut into fragments using enzymes.

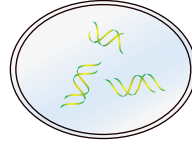

3 Pieces of DNA are separated in a gel using electric current. This process is called electrophoresis and is very similar to chromatography. Small DNA pieces move faster and further than larger ones.

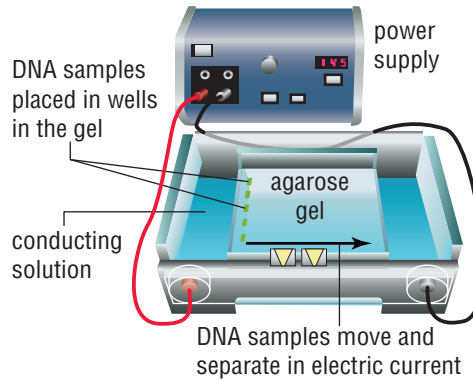

4 DNA band pattern in the gel is transferred to a nylon membrane.

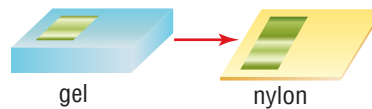

5 A radioactive DNA probe is added that binds to specific sequences in the DNA bands.

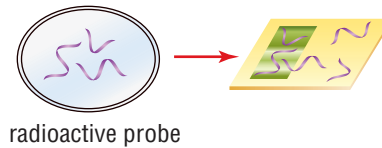

6 The excess probe material is washed away, leaving a unique pattern.



7 The radioactive DNA pattern is transferred to X-ray film, giving the DNA fingerprint.

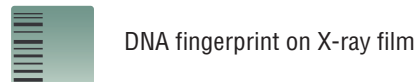
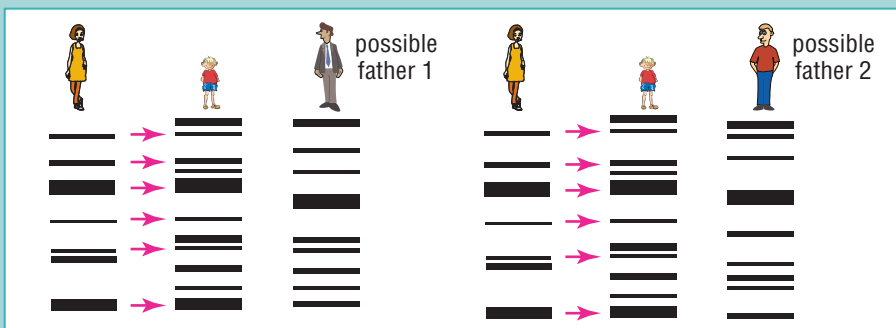

Fig 3.4.13 The process of DNA fingerprinting.



Go to Science Focus 3 Units 1.1, 1.3

Fig 3.4.14 A comparison of DNA fingerprints can show who the father is. Just as importantly, it will show who is not the father.

STUDENT ACTIVITIES

- Analyse** Figure 3.4.14 on page 117 and determine the father of the child.
- A set of DNA fingerprints was found at a crime scene (labelled C). During the investigation, the DNA fingerprints were taken from the victim (V), the two likely suspects (S1 and S2) and a standard set for reference (St). **Analyse** the set of fingerprints shown in Figure 3.4.15 and determine who committed the crime.

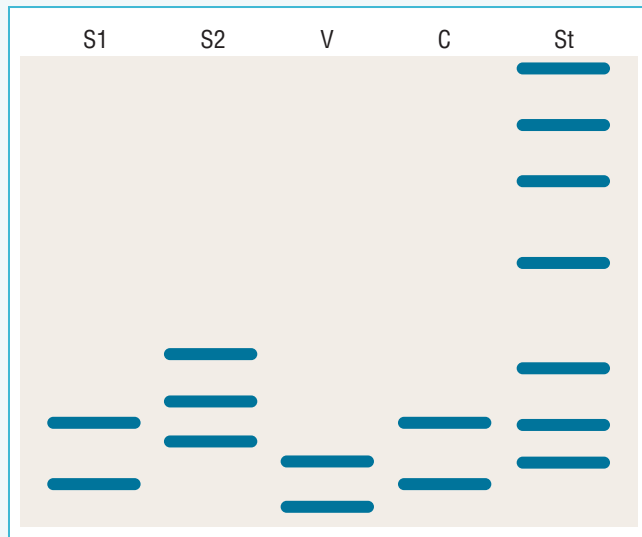

Fig 3.4.15

- Some in the community have expressed concern that the increasing use of human DNA and genetic information could lead to an 'invasion of privacy' and that the information obtained by screening a person's DNA might then be used for the wrong reasons.
 - Discuss** this issue with classmates and propose the advantages and disadvantages that screening of each person's DNA could have for society.
 - Evaluate** this information and make a judgement as to whether the collection of DNA-related information should be allowed in the future, and if so, under what conditions.
- The base-nitrogen sequence shown below represents a gene located in a section of DNA that a forensic scientist wants to analyse. Only one strand of the DNA is shown. The code for the gene is shown in red.

AATGCGTCTGATATCTCCC**ATGCACGCGCCCGGGATTACGTACCCGGGATCCGCGTAAC**ACTGATATCTATT

To cut up the DNA, a restriction enzyme that recognises a particular sequence of six bases is to be used. The restriction enzyme uses the base sequence GATATC to allow it to identify the place where the DNA should be cut.

- Copy** the base sequence and identify each location where the restriction enzyme will attach to the section of DNA for cutting.
 - Propose** reasons why this particular restriction enzyme was chosen to locate the place to cut the DNA.
 - Construct** a sequence of six bases for a gene probe that will attach to the gene shown in the diagram.
- It has recently been suggested that the use of DNA for crime solving might have serious flaws. The technology is now so freely available that a criminal could potentially take someone else's DNA, use a PCR (polymerase chain reaction) to make lots of it, and then deliberately spread it around at a crime scene.
 - Conduct research to find out how DNA is replicated using PCR.
 - Produce a poster or cartoon to demonstrate how a sample of DNA can be replicated by PCR. **L**
 - Using an example, **assess** whether criminals using this technique could influence the use of DNA as evidence of their crime.
 - Imagine you are in a small town where a serious crime has been committed. In order to help catch the criminal, the police have asked everyone to give a DNA sample for analysis. This would either eliminate people as suspects or, hopefully, confirm the criminal's identity.
 - Discuss** whether giving a DNA sample should be voluntary or compulsory.
 - A person has chosen not to give a DNA sample as they fear their genetic information may be misused. **Account** for this person's decision.
 - Do you think that a person who chooses not to give a DNA sample should be treated any differently to a person who does give one? **Justify** your answer.
 - Propose** a set of guidelines that could be used when collecting DNA samples for analysis in this town, to convince people that their DNA will not be misused. **L**



Fig 3.4.16 Police collect DNA using a cottonbud-like swab and seal the sample in a tube for testing. A swab to collect cells is usually taken from inside the cheek.

3.4 INVESTIGATING

Investigate your available resources (for example, textbooks, encyclopaedias, internet) to gather information about how one of the following biotechnologies works:

- electrophoresis
- restriction enzymes
- gene probes.

Draw a flow chart using a series of diagrams and text to demonstrate how your chosen biotechnology works.

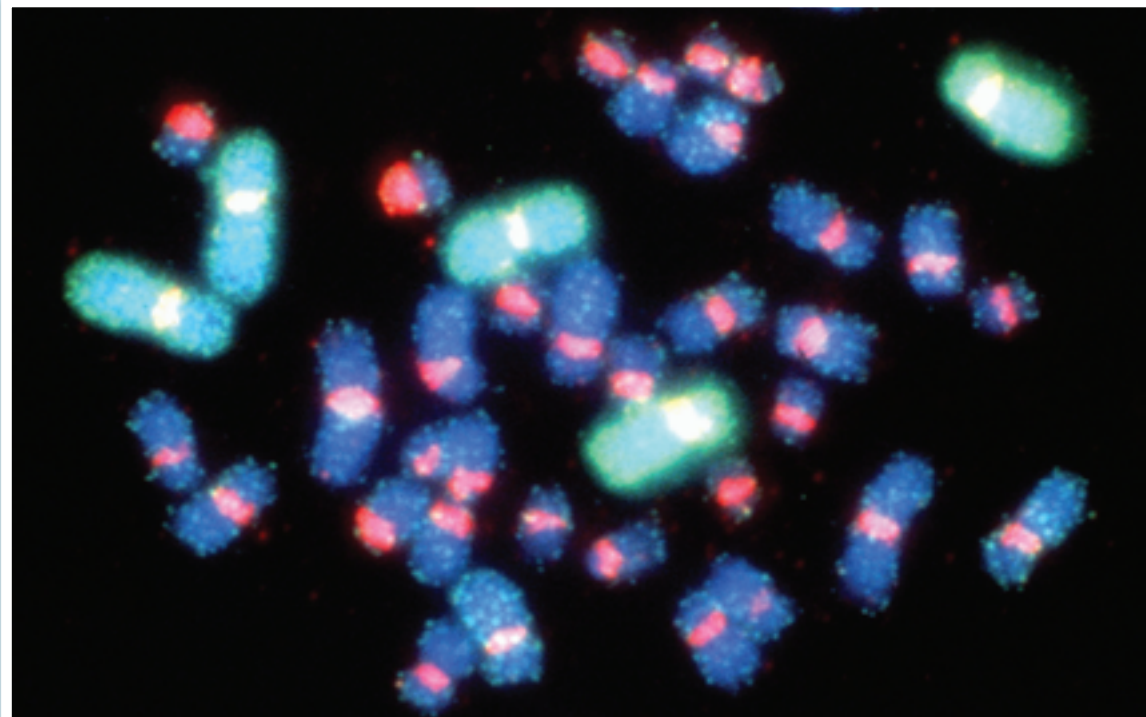

Fig 3.4.17 Gene probes

CHAPTER REVIEW

Remembering

- 1 Recall** basic definitions in genetics by matching the following terms to the appropriate description.

Terms	Descriptions
meiosis	the chemical that carries the genetic code
mitosis	a hereditary unit
diploid	cell division producing gametes
haploid	cell division producing daughter cells identical to the parent cell
gene	a cell having two of each type of chromosome
DNA	a cell having one of each type of chromosome

- 2 State** the name given to the twisted structure of DNA.
3 Specify what chemicals make up its uprights and rungs.
4 Recall basic definitions in gene manipulation by matching the following terms to the appropriate description.

Terms	Descriptions
codon	causes a spontaneous change in a gene or chromosome
genetic map	a small piece of DNA that recognises a gene
plasmid	an organism with a new gene
Gene probe	shows positions of genes on chromosomes
recombinant DNA	a circular piece of DNA
transgenic organism	a molecule containing DNA from two organisms
mutagen	a sequence of three bases that codes for an amino acid

Understanding

- 5 Describe** two influences that make you what you are.
6 Define the terms genes, chromosomes and DNA.
7 Briefly outline the process of replication of DNA.
8 Explain how a mutation may be:
- harmful to an individual but have no effect on the species
 - harmful to the species but not to the individual
 - beneficial to the species
- 9 Explain** what is meant by:
- gene technology
 - cloning
 - gene cell therapy

Applying

- 10 Identify** two ways in which you resemble:
- your mother
 - your father
- 11** In Mendel's pea plants, long-stem flowers were dominant over short-stem flowers. Stem length is controlled by a single gene with dominant and recessive alleles. **Use** this example to explain what is meant by the terms:
- allele
 - genotype
 - phenotype
 - homozygous
 - heterozygous

Analysing

- 12 Classify** the following statements as belonging to mitosis or meiosis.
- It involves replication of DNA strands.
 - Two daughter cells are produced.
 - Four daughter cells are produced.
 - It produces cells with half the chromosome number of the parent cell.
 - It occurs in most body cells.
- 13** In fruit fly, the allele that produces red eyes (*R*) is dominant over the allele for white eyes (*r*). A red-eyed heterozygous fruit fly is crossed with a white-eyed fruit fly. **Analyse** this cross and:
- state the genotype of each fruit fly
 - list the possible genotypes of the offspring
 - state the percentage of each genotype listed above **N**
 - state the possible phenotypes of the offspring **N**
 - state the percentage of offspring that would be expected to have each of the phenotypes listed above **N**
- 14** Use examples to **contrast** continuous and discontinuous variation.
- 15** The ability to taste a bitter chemical known as PTC is dominant over the inability to taste it. Three children in a family can taste PTC; one cannot. **Analyse** whether it is possible for both parents to be:
- non-tasters of PTC
 - tasters of PTC

- 16** The father of a child has blood group AB; the mother has group O. **Analyse** this situation and list the possible blood groups the child could have.
- 17** A pedigree for a rare X-linked disease is shown in Figure 3.6.1. The symbols used to show the relevant genes are X^m for the recessive gene on the X chromosome and X^M for the normal gene on the X chromosome.
- a Analyse** this pedigree and specify the genotype of:
- the male 3 in generation II
 - the female partner of generation II male 3
 - generation III male 1
- b Identify** whether the disease is carried by a dominant or a recessive gene.
- c** Female 2 of generation III female 2 and her partner later have a male child. **State** the probability that the boy will have the disease.

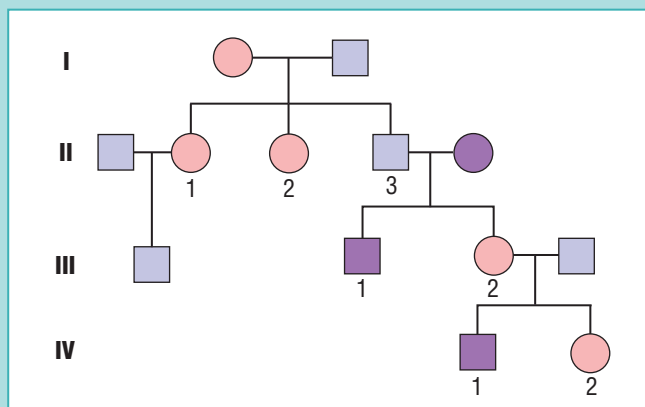

Fig 3.6.1

Evaluating

- 18 a State** the percentage of your total DNA base sequence that is the same as that of your classmates. **N**
- b** Is it possible for two people to have exactly the same total DNA base sequence? **Justify** your answer.
- 19 Propose** three arguments:
- for the use of genetically modified foods
 - against the use of genetically modified foods

Creating

- 20** For snapdragons, a cross between a plant with red flowers (RR) and a plant with white flowers (WW) produces a plant with pink flowers. The following snapdragons are crossed. **Construct** a Punnet square for each and predict the expected ratio of red, white and pink flowers in each cross:
- red-flowered and pink-flowered plants
 - two pink-flowered plants
- 21** In humans, the ability to roll the tongue (R) is dominant over the allele for being unable to roll the tongue (r). A tongue-rolling heterozygous person is crossed with a person who cannot roll their tongue.
- State** the genotype of each person.
 - Construct** a Punnet square showing this cross.
 - List** the possible genotypes of their offspring.
 - State** the percentage of offspring that would be expected to have each of the genotypes listed above. **N**
 - List** the possible phenotypes of the offspring.
 - State** the percentage of offspring that would be expected to have each of the phenotypes listed above. **N**
- 22** Albinism is caused by a single recessive gene (a). Two people heterozygous (Aa) for albinism produce a child.
- State** whether the parents are albino or not.
 - Construct** a Punnet square showing all the possible genotypes.
 - State** the probability that the child will be albino. **N**
- 23** Colour blindness is an X-linked recessive disorder. The symbols used to show the relevant genes are X^n for the recessive gene on the X chromosome and X^N for the normal gene on the X chromosome. A colourblind female has children with a non-colourblind male. Analyse this situation and:
- construct** a Punnet square showing the different possible genotypes of their offspring
 - explain** why their daughters will be carriers of the disorder.
 - state** whether the identify their sons would be affected or not.

Worksheet 3.6 Crossword

Worksheet 3.7 Sci-words



4

Health and disease

Prescribed focus area

The implications of science for society and the environment

Key outcomes

5.4, 5.8.4

- Different body systems respond in different ways to infectious and non-infectious diseases.
- Infectious diseases are commonly transmitted by micro-organisms such as bacteria, viruses, fungi and macro-organisms such as parasites.
- Non-infectious diseases cannot be caught from others. They are inherited, caused by genetic mutation, exposure to mutagens or are the result of lifestyle choices.
- Different cultures and groups within a society may have different views relating to health issues.
- Aboriginal people have their own traditional remedies and methods of healing.

- Abnormal cell function can cause uncontrolled growth causing a tumour and cancer.
- The health of Aboriginal people was dramatically affected by the arrival of Europeans and the changes to their way of life.

Essentials

Additional

context

You probably think that you are in good health because, like most teenagers in Australia, you are well-fed, rarely get ill and are physically able to do all of the things that you want to. For some people, however, it is sometimes difficult to tell whether they are healthy or not. This is because the term 'good health' means

many different things to different people. A slum-dweller may think that they are in good health because they are able to walk and work when many of those around them cannot. You may look at that same person and think they are in very poor health because they may be malnourished or have skin diseases from contaminated water.

Requirements for good health



Good **health** is not the total absence of disease, but it means that a person has an overall sense of wellbeing and is able to function well within their environment.

Although there are many factors that contribute to good health, three of the main ones are:

- good nutrition
- a healthy mind
- adequate exercise.

It is important to pay attention to all of these factors or you quickly become unhealthy: it is not enough to eat well and have a healthy mind if you never exercise and eat only cheeseburgers.

Good nutrition

Organisms must take in **nutrients** to survive.

A nutrient is any substance that is used by an organism either as a source of energy or to build living tissue.



Fig 4.1.2 If you function effectively in your environment then you are in good health.



Fig 4.1.1 Slum dwellers are prone to malnutrition and disease.

Fats, proteins and carbohydrates are the main nutrients for the human body as they provide us with our energy.

A **balanced diet** consists of a variety of foods including fresh fruit and vegetables, breads and cereals, dairy products, fish, lean meats and water. Junk foods might be tasty and widely available but are high in fat, sugar and salt. These nutrients should make up only the smallest part of your food intake.

Science Fact File

Energy

- Energy is measured in joules (J) or kilojoules (kJ).
- 1000 J = 1 kJ.
- Another unit of energy is the calorie: 1 calorie = 4.2 kJ.
- Fat supplies about 38 kJ of energy per gram, while carbohydrates and protein each supply about 17 kJ per gram.

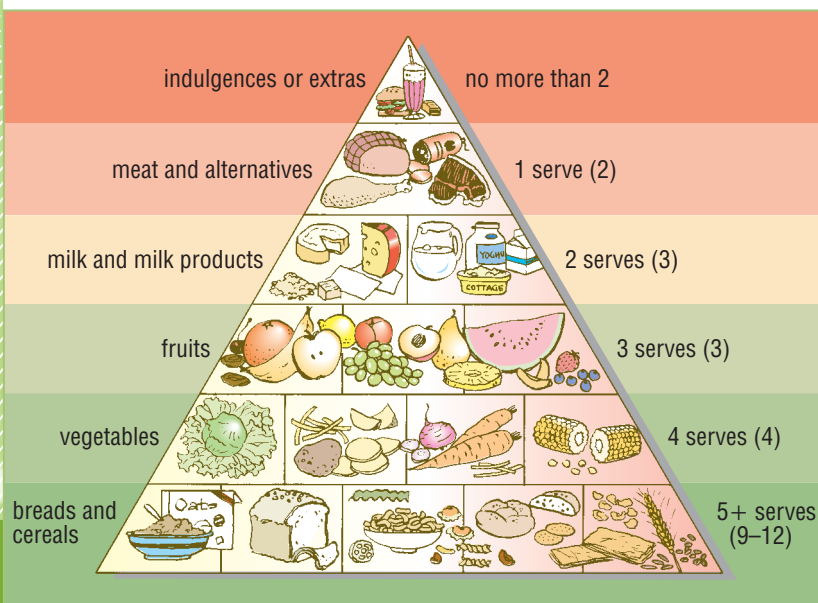

Fig 4.1.3 The food pyramid needed for a balanced diet: chips, fried foods and lollies are fine as long as you don't eat too many or too often. Eat more of the foods lower down on the pyramid.

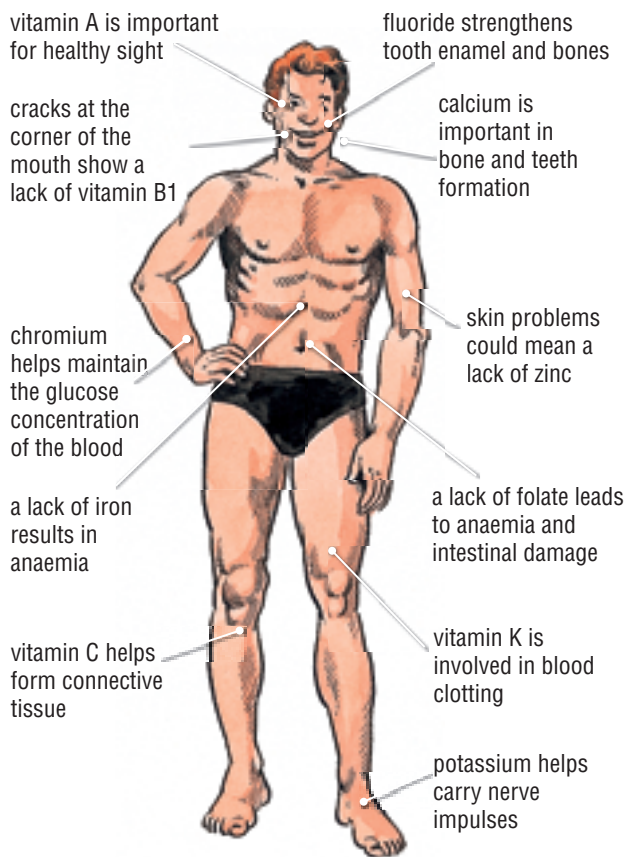

Fig 4.1.4 Uses of some vitamins and minerals in the body and the effects of deficiency

- **vitamins** like vitamin A and C and **minerals** like iron and calcium are essential in small amounts. They are naturally supplied in a balanced diet and so vitamin and mineral supplements are usually not necessary. A strange fact is that too much of some vitamins can be just as dangerous as too little.

Prac 1
p. 128



Fig 4.1.5 A vitamin C deficiency can lead to scurvy, resulting in overgrowth of gums, bleeding and loose teeth.

Science Clip

The low-down on fat

Many foods that are advertised and labelled as fat-free are extremely high in sugar. Although this sugar makes the food tasty, too much sugar can lead to many health problems and will eventually be converted into fat anyway!

Metabolism and food intake

As well as needing energy for movement and normal body functions, your body needs to be kept at 37°C, the temperature at which your organs work best. The amount of energy that different people need depends on their metabolism. **Metabolism** is the rate at which a person uses their energy. This rate depends on their age, health and activity levels.

Children are still growing and need more energy than adults. Highly active people require more energy than inactive (sedentary) people. If more energy is taken in than the body can use, then the excess is stored as fat. If you use more energy than you take in, then fat and carbohydrates in your body will be broken down to use for energy. Your body starts to break down muscle protein in the unlikely event that these carbohydrates and fats run out.

Average teenagers require about 10 000 to 12 000 kJ of energy per day. This is roughly the same as the amount of energy it would take to raise the temperature of 38 litres of cold water to boiling point (100°C)!

In addition to energy-giving nutrients, your body needs other types of nutrients to stay healthy:

- **dietary fibre** is important for the health of your digestive system

Science
Clip

GI Joe

The glycemic index (GI) is used to rate foods containing carbohydrates. Sugars are a form of carbohydrate and the GI measures how quickly the sugars in food are absorbed into the blood. Foods are given a GI score out of 100, with pure glucose being taken as the standard (GI = 100). High GI foods are absorbed quickly and give a rush of energy followed by a state where alertness and activity are depressed. In contrast, low GI foods take longer to be absorbed. This gives you a more sustained supply of energy and allows you to concentrate and remain active for much longer. Your performance in endurance events such as long-distance running (and even homework!) can be improved by eating low-GI foods two hours before the activity. Low-GI foods are particularly important for diabetics.



Fig 4.1.6 Low GI foods are better for sustained performance. High GI foods give a burst of energy but result in you feeling 'down' soon after.

A healthy mind

An old saying states that the mind is the greatest healer which implies that the mind strongly influences your wellbeing. Many alternative healing methods are based on this idea. Your thoughts and feelings have the power to affect every system in your body.

Psychosomatic illnesses are those caused by your thoughts and feelings (psycho = mind, somatic = body). Some people think of these as imaginary illnesses, but their effects on the body are very real. Examples of psychosomatic illnesses are:

- some forms of **depression**—there are many triggers for depression, including stress, drug use and family conflict. Some individuals may be more at risk

because of their genetic make-up, which may cause variation in the chemical message systems of the brain

- **anorexia nervosa**, an eating disorder characterised by starvation
- **bulimia nervosa**, another eating disorder marked by a binge–purge cycle.

Other diseases, such as acne and constipation, can be made much worse by negative thoughts and feelings.

Adequate exercise

You need to exercise to become healthy and stay healthy. Exercise can range from playing vigorous sports like tennis, to dancing or a brisk walk. It is important to choose something you enjoy or else you will most likely stop doing it. The exercise you do will need to change as you get older. Whatever your age and fitness, most people should aim to do some type of weight-bearing exercise that increases their heart rate for at least 20 minutes, at least three times per week. Weight-bearing exercise is anything that makes you work against gravity. It can be as simple as walking up stairs, lifting weights in the gym, skipping, playing basketball or jogging.

Worksheet 4.1 The glycemic index and load



Fig 4.1.7 Exercise need not be as strenuous as basketball—brisk walks or jogging can provide the exercise you need.

4.1 QUESTIONS

Remembering

- List** the three main factors that contribute to good health.
- List** the three main nutrients that give your body its energy.
- State** whether the following statements are true or false.
 - Protein provides more energy per gram than fat does.
 - Energy is measured in joules or kilojoules.
 - $1000\text{ J} = 1\text{ kJ}$
 - Your body doesn't need energy when you are asleep.
 - Children need more energy than adults.
- Name** two examples of each of the following and specify how each is used in the body:
 - vitamins
 - minerals
- State** the ideal body temperature for a human.
- List** the factors that affect metabolism.
- Specify** how often and how long you should exercise each week and state what type of exercise it should be.
- Recall** basic definitions by selecting the appropriate word for each.

Term	Definition
psychosomatic	substance taken in and used for energy or to build tissue
nutrient	caused by the mind but with very real symptoms
organism	a mineral used by the body
calcium	any living thing

Understanding

- Explain** why health is a relative term.
- Describe** what happens to the energy in the food you eat if it is not all used up.
- The type of exercise needs to change as a person gets older. **Explain** why.
- Psychosomatic illnesses are those caused by thoughts and feelings.
 - List** examples of two negative thoughts or emotions.
 - Predict** how these thoughts would affect the body.
 - List** three examples of known psychosomatic illnesses.

Applying

- Identify** three unhealthy things you do that you could change.
- Use** the food pyramid shown in Figure 4.1.3 to **list** the types of foods that you should eat:
 - the most of
 - a moderate amount of
 - the least of
- Calculate** how many kilojoules (kJ) are in the following:
 - 1000 J
 - 2500 J
 - 3271 J
 - 500 J
 - 880 J
 - 4 calories
 - 2.5 calories **N**
- Every day a teenager needs enough energy to heat 38 litres of water to 100°C just to keep them warm. **Identify** whether this volume is equivalent to a bucket, a rubbish bin, a bathtub or a swimming pool. **N**
- Identify** age-appropriate activities to keep these people healthy:
 - a Year 10 student
 - a 40-year-old man
 - a 70-year-old woman

Analysing

- Analyse** the energy needs of the people below. **List** them in order from the person who would need to take in the most energy per day to the person who would need the least:
 - a baby
 - NRL players
 - an active teenager
 - a postie
 - a teenager who spends most of their free time on the internet
- Calculate** how many joules (J) are in the following:
 - 31 kJ
 - 0.7 kJ
 - 2 calories
 - 2 g of fat
 - 10 g of carbohydrates **N**

Evaluating



- 20** Most people eat foods labelled 'fat-free' or 'low in fat' because they think such foods will help them to lose weight. **Assess** whether these labels are misleading or not.
- 21** **Assess** whether teenage girls need to eat more than teenage boys. **Justify** your answer.
- 22** Astronauts tend to lose muscle mass in space. **Propose** a reason for this.
- 23** Suppose a slightly overweight man went on a hunger strike to achieve some political aim. **Assess** what would happen over the next few weeks to his body and **describe**, in order, the three main changes that would happen to him.

Creating

- 24** **a Construct** a daily menu for a balanced diet. Think carefully about what you might include.
- b** Have another person evaluate the balanced diet you have designed. Is it really balanced? Could it be improved?
- 25** **Design** an exercise routine that will ensure that you do a healthy amount of exercise every week.
- a Construct** a journal to record what you eat for one week.
- b** After the week, **analyse** your findings to determine whether you are eating a balanced diet according to the food pyramid in Figure 4.1.3.
- c Recommend** changes to your diet to make it healthier.

4.1 INVESTIGATING

Investigate your available resources (for example, textbooks, encyclopaedias, internet) to complete the following tasks.

- 1 a** Find out about a particular vitamin, what it does and what happens if you have too much of it (toxicity) or too little (deficiency).
- b** Design a label for a bottle of your chosen vitamin. You should include enough information so that people reading the label will understand exactly how it should be used and what the effects will be. 
- 2 a** Research the diseases prevalent in less developed countries in order to find out:
- why these diseases are so common
 - how these problems could be eradicated.
- b** Present your information in one of the following ways:
- a letter to the World Health Organization in which you recommend action that should be taken to reduce the amount of disease in slums
 - a speech to Year 10 students encouraging them to donate money to a campaign for funds to improve the health in those areas. 
- 3 a** Research alternative healing methods like acupuncture, cupping, candle waxing, massage, Reiki or reflexology.
- b** Explain how the healing technique works.

- c** Evaluate whether the healing techniques studied are effective.
- d** Write an article for a medical journal to explain your findings. Remember that your information should be backed by scientific evidence. 

e-xploring

To find out more about nutrition, a list of web destinations can be found on **Science Focus 4 Second Edition Student Lounge**. Visit the nutrition café and complete the following activities.

- Solve the mystery of the missing nutrients for the case studies in the 'Nutrition sleuth'. Record how many cases you solved.
- Find out whether your diet is healthy or not by visiting the 'Have-a-Bite Café'. Use your findings to deduce which aspects of your diet are already healthy and which aspects could be improved.

Visit the 'Better Health Channel' and select a healthy menu for one day that provides some of the nutrients you have discovered are missing from your diet.



4.1 PRACTICAL ACTIVITIES

1 Orange juice and vitamin C

Aim

To determine which brand of orange juice has the most vitamin C

Equipment

- starch suspension
- iodine solution
- 4 test tubes
- test-tube rack
- vitamin C solution (dissolve vitamin C tablet or powder in 50 mL of water)
- 200 mL beaker
- 3 different brands of fresh orange juice
- stirring rod
- dropper
- lab coat
- safety glasses
- gloves

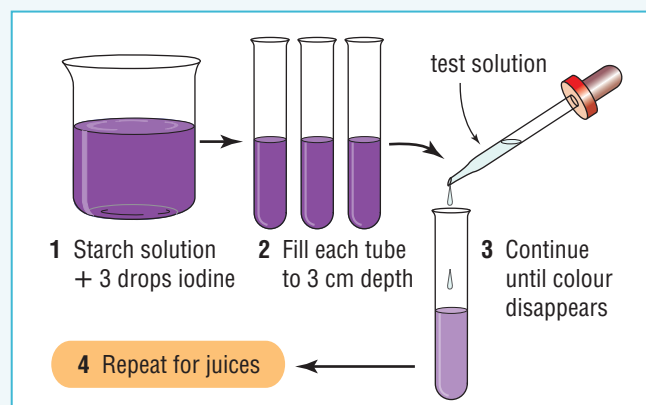

Fig 4.1.8

Method

- 1 Half-fill the beaker with starch suspension. Add 3 drops of iodine solution. Stir well. The colour of the mixture should now be purple.
- 2 Pour 3 cm of this into each test tube (make sure your test tubes are the same size).
- 3 Using the dropper, drop vitamin C solution into the first tube until the blue colour disappears. Record how many drops were required.
- 4 Do exactly the same for the other three test tubes, but use the different juices instead of the vitamin C solution. Record how many drops of each were required until the solution was colourless. The more drops, the less vitamin C that juice contained.

Questions

- 1 **Deduce** which brand had the most vitamin C and which had the least.
- 2 **Construct** a bar graph to show your results. **N**
- 3 **List** five foods that you know are good sources of vitamin C.

Prescribed focus area

The implications of science for society and the environment



After some 60 000 years alone on the continent, from 1788, Australian Aborigines suddenly had to contend with European settlement. Not only did this dispossess them from their land and their traditional hunting grounds, it also began the breakup of traditional social structures and damaged the passing down through generations of the Dreamtime stories. Until the 1970s, some Aboriginal children were also forcibly removed from their parents—these children are known as the Stolen Generation.

Although it is difficult to determine the exact extent of all these changes to Aboriginal culture and lifestyle, the impact on the health of Aboriginal people has been profound: statistically, Australians of Aboriginal descent now have a shorter life than those of European descent.

Aboriginal diet

Traditional diet

Before white settlement, the Aboriginal people were hunter-gatherers, collecting plants, seeds, nuts and fruits and hunting animals. Most of the food they collected was low in fat and sugars (low in kilojoules), but high in carbohydrates, fibre, protein and nutrients. Kangaroo meat, honey, witchetty grubs and insects were particularly energy-rich. Their diet varied daily with the

weather and the seasons which influenced the amount and type of plants and animals available. Overall the diet of the first Australians was a healthy one. The hunter-gatherer lifestyle also gave the Aboriginal people plenty of exercise. As a result, diet-related diseases such as cardiovascular disease and diabetes were uncommon.

New foods

As European settlement spread, Aboriginal people had less chance to gather their traditional foods. Towns and farms displaced them from the land and destroyed many of the hunting areas. New animals, plants, weeds and more frequent bushfires further restricted their food-gathering activities. Other Aboriginal people were shifted to government or church settlements or worked on cattle stations. Here, movement was restricted or there was insufficient time left in the day to forage for food in the old way. Foods such as flour, sugar and processed meat began to replace the traditional Aboriginal diet, resulting in a lack of nutrients such as protein, vitamins and minerals.

Modern diet

Modern Aboriginal diets are very different to those of their ancestors. They now resemble Western diets in that they are high in fats and sugar, making them high in kilojoules yet low in nutrition. Likewise, exercise has decreased since there is now no need to go out and gather traditional food. The range of foods available to outback communities is very limited and very expensive



Fig 4.1.9 The traditional diet of Aboriginal people was a lean and healthy one.



Fig 4.1.10 Regardless of where they live, the diet of Aboriginal people has changed radically. 'Lifestyle' diseases such as diabetes and cardiovascular disease are now common.



as all of it needs to be transported across large distances. Fresh fruit and vegetables are rare.

Surveys indicate that urban Aboriginal people eat more fast food and salt than non-Aboriginal people. Aboriginal people of the Northern Territory consume more sugar, white flour and carbonated soft drinks than the Australian average. The typical modern Aboriginal diet, whether city or country, is especially low in vitamin C, calcium and magnesium.

These factors have led to an exceptionally high rate of 'lifestyle' diseases such as heart disease, obesity, diabetes, high blood pressure, certain cancers, and stroke.

The introduction of European diseases

Early European settlers brought many new diseases to Australia. Aboriginal people had no resistance and no traditional remedies. Smallpox plagues swept through Aboriginal Australia, killing as much as half the population. Influenza (flu), tuberculosis, syphilis and other diseases all reduced the Aboriginal population even further.

Traditional medicine

Traditional Aboriginal medicine is a complex system linked to the belief and culture of the people, their knowledge of the land, its flora and fauna. Traditional medicine and healthcare are holistic, taking a whole-being approach. It recognises the social, physical and spiritual dimensions of both health and life. Sorcery remains a potent belief and the casting and removing of spells is still practised. Some Australian Aboriginals still



Fig 4.1.11 Applying white clay in a traditional healing ceremony

perform ceremonies consisting of singing songs and painting designs on the sick person. The sick may also be massaged with fat and red ochre, as well as being given herbal medicines to treat the body.

Some Aboriginal Australians use a range of remedies for illness—wild herbs, animal products, steam baths, clay pits, charcoal, mud, massages, string amulets and secret chants. Many of the remedies directly assist healing. The medicinal properties of goanna oil, aromatic herbs and the tannin-rich inner bark of certain trees have long been known to Aboriginal people. Scientific studies too have identified the worth of many of these traditional medicines. Compounds coming from the Moreton Bay chestnut or black bean, for example, are showing promise as a treatment for HIV/AIDS.

STUDENT ACTIVITIES

- 1 Aboriginal Australians were traditionally hunter-gathers. **List** foods that fit this way of life.
- 2 **Outline** the nutritional benefits of the traditional Aboriginal diet.
- 3 **Explain** why the traditional Aboriginal diet was considered a balanced one.
- 4 **Compare** the traditional Aboriginal diet with:
 - a a modern Aboriginal diet
 - b your own diet
- 5 **List** three food types introduced by colonisation.
- 6 **List** three nutrients that were reduced after colonisation.
 - a **Propose** reasons why the Aboriginal diet changed so much after European settlement.
 - b **Recommend** ways in which the rest of the Australian society could support Aboriginal people to improve their diet.
- 7 Aboriginal people caught many diseases from the first colonising Europeans. **List** four of these diseases.
- 8 **List** two reasons why Aboriginal people were vulnerable to these diseases.
- 9 Diet-related diseases have also affected the health of Aboriginal people. **List** three examples of such diseases.
- 10 Influenza was also introduced into Australia by early settlers. **Propose** reasons why the flu would be more deadly to Aboriginal people than to the European settlers.

context

Diseases are anything that makes you feel unwell or makes you unable to function properly in your environment. These medical conditions cause

symptoms like nausea, rashes, fever, blurred vision or stiffness in your joints. The symptoms indicate that your body is not working properly.

Pathology

The study of disease is called **pathology** (*pathos* = suffering, *logos* = study) and people that work in this field are called **pathologists**. Some of the common terms used in pathology are:

- **organism**—living thing, plant or animal
- **micro-organism (microbe)**—an organism so small that it can only be seen with a microscope. Sometimes micro-organisms consist of only one cell. Bacteria and viruses (sometimes referred to as germs) are examples of micro-organisms
- **agent** or **pathogen**—anything that causes disease
- **host**—the organism being affected by the agent. When you have a cold, you are the host and the cold virus is the agent
- **vector**—an organism that carries a pathogen and transmits it to the host, but is not affected by it. Mosquitoes are vectors. They transmit diseases such as malaria and dengue fever without being affected by them
- **parasite**—an agent that uses the host for food or shelter. Intestinal worms and fleas are examples of parasites



Fig 4.2.1 The symptoms of chickenpox are clear in this child.

- **infection**—invasion of the body by foreign organisms
- **infectious**—the invading agent can multiply easily in the host and be passed onto other host organisms
- **virulence**—measures how much damage a disease does to the host. Highly virulent diseases cause very serious symptoms, perhaps death.



Fig 4.2.2 You are an organism, as is a dog and the grass—sometimes you and the dog will act as a host for other organisms such as fleas, ticks, intestinal worms, or lice and micro-organisms such as bacteria, viruses and fungi.



Fig 4.2.3 Fleas are parasites. They are also known as agents as they can cause disease.

From bad to worse

There will always be disease in the world. The following special terms are used by pathologists to describe how many people are affected and how far the disease has spread:

- **endemic**—a disease that regularly affects a small number of people in the population
- **epidemic**—higher than normal numbers of people are affected by a particular disease in a certain place
- **outbreak**—a disease that suddenly gets out of control
- **pandemic**—an outbreak that goes global, placing everyone on the planet at risk.



Fig 4.2.4 Ebola is a highly virulent disease that kills most of its victims within a few days. So far, Ebola has only affected remote African villages: it kills so quickly that it has insufficient time to spread beyond them. Ebola is spread easily by even the tiniest drop of saliva, blood, urine or faeces. For this reason, doctors treating Ebola patients must wear protective clothing.

Causes of disease

Disease can be caused by many factors—some infectious, some avoidable and others you are born with. Here are some examples.

- The body can be invaded by micro-organisms such as bacteria, viruses, protozoa and fungi. These diseases are usually infectious.
- Parasites such as worms can be transferred from others who are already infected with them. These then invade the body.
- Some part of the body can malfunction due to some imperfection or fault. Diabetes, for example, can develop if the pancreas isn't working properly.
- Environmental factors can cause your body not to function properly. These factors could be air or water pollution or your everyday 'normal' exposure to UV radiation in sunlight.

Science Fact File

Legionnaire's disease

In July 1976, the Bellevue-Stratford Hotel in Philadelphia hosted the 58th state convention of the American Legion Department of Pennsylvania. Not long after, 34 of the participants were dead of a pneumonia-like illness and a further 221 were seriously ill.

A previously unknown bacterium caused the outbreak and it took one year to identify it. It was named *Legionella*, and the disease it caused legionnaire's, in memory of those it had infected. *Legionella* bacteria reproduce best in the warm, stagnant water commonly found in hot-water tanks, cooling towers, or large air-conditioning systems like the one in the Bellevue-Stratford hotel. *Legionella* outbreaks occasionally occur in buildings where the water-cooling systems have not been cleaned or disinfected properly. In NSW, between 40 and 90 cases of legionnaire's are diagnosed each year and at least eight outbreaks have occurred over the last 15 years. An outbreak of legionnaire's disease infected 10 people who happened to be passing through Circular Quay, Sydney, in late 2006. Luckily, none of the infections were fatal. Twenty-five air-conditioning cooling towers in the area were inspected. While one was found to have dangerously high levels of *Legionella*, others had the bacteria in low (but considered safe) levels.

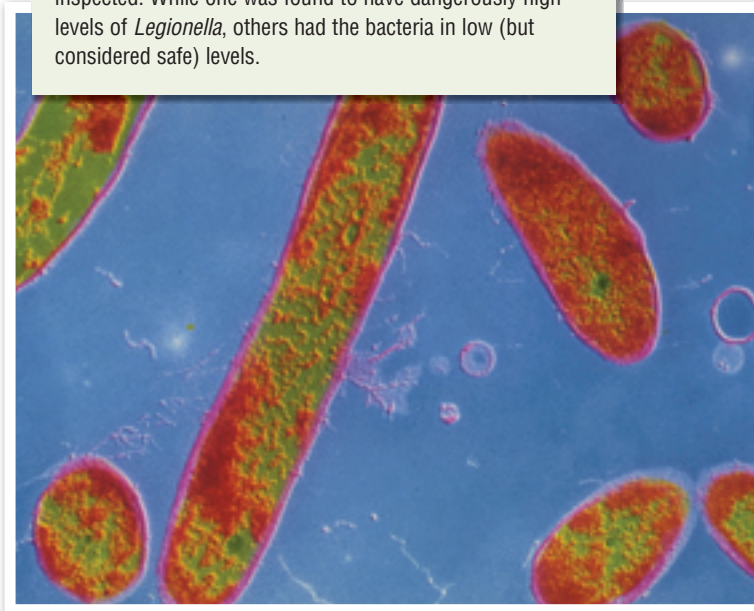

Fig 4.2.5 *Legionella* bacteria

- You may have a genetic disease such as haemophilia or colour-blindness that your parents either had or 'carried'. You do not 'catch' these diseases, but are born with them.
- Lifestyle factors can cause disease. These factors are 'self-inflicted' and include drug abuse, overuse of alcohol, smoking, sunbaking and high-fat, high-sugar diets.

Worksheet 4.2 Outbreak!



4.2 QUESTIONS

Remembering

1 **Recall** basic definitions in pathology by matching the best description to each term.

Term	Description
symptom	study of disease
pathology	causes disease
microbe	can be passed on to another host
agent	outward sign of disease
host	agent using host for food or shelter
parasite	very small organism
infectious	organism being affected by agent

2 **State** three examples each of:

- a organisms
- b micro-organisms
- c parasites

3 **Name:**

- a an environmental factor that can cause disease
- b a lifestyle disease
- c disease caused by a malfunctioning pancreas

4 **List** in order of worsening scenarios:

- pandemic
- outbreak
- endemic
- epidemic

Understanding

5 **Modify** the following statements so that they become correct.

- a Diseased people can still function well in their environments.
- b A host uses a parasite for food or shelter.
- c Not all diseases are infectious.
- d Symptoms like blurred vision are not signs of disease.

6 **Use** an example to outline the features of a disease and its symptoms.

- a **List** three diseases you have had.
- b **Describe** the symptoms and treatment for each disease.

Applying

7 A flea is a parasite. **Identify** its food source.

8 A kitten has intestinal threadworms.

- a **Identify** the host and the agent.
- b **Specify** what type of agent is causing the condition.

9 **Identify** three behaviours or actions that could easily spread disease.

Analysing

10 **Use** a scale of 1 to 10 to **classify** each of the following diseases according to their virulence. Assign the disease 10 if it has a high virulence and 1 if it has a low virulence.

- a Ebola kills most of those infected with it within a few days.
- b Pimples never kill anyone, regardless of how bad they are.
- c Syphilis kills most of its untreated victims within 10 years.

11 **Distinguish** between the terms:

- a endemic and epidemic
- b agent and host

12 Ebola is an incredibly infectious disease that kills quickly and horribly. SARS (sudden acute respiratory syndrome) is also highly infectious and also deadly. Its incubation is longer, meaning that it can spread. When it last hit Hong Kong, whole apartment blocks were quarantined and treated like prisons with no-one allowed to exit or enter. Other people were forcibly detained in prison camps. What controls do you think authorities should have when confronted with the spread of a disease like Ebola or SARS? **Discuss** the rights of the individual with the rights of the wider community. In groups, come to an agreed decision.

Evaluating

13 a **Explain** why Ebola has not spread outside the villages it attacks.

b **Propose** what would happen if Ebola was less virulent, taking a year to kill and not the few days it takes now.

14 Very small infectious agents spread disease easily. **Propose** reasons why the size of the agent influences the spread of a disease.

15 The following are all known to transmit bacterial and viral diseases. **Propose** ways of stopping these forms of transmission:

- a not washing your hands after going to the toilet
- b using a plate for raw meat and then re-using it for cooked meat, without washing the plate
- c leaving fish out of the refrigerator for an hour before cooking
- d eating food that has dropped onto the floor
- e piercing your own ears, nose or lip

- 16** Household evaporative air conditioners regularly dump the water in their holding tanks, replacing this water with new water.
- Identify** the disease that is being avoided by doing this.
 - Specify** what micro-organism is the cause of this disease.
 - Explain** why commercial air-conditioning units are regularly disinfected.
 - Propose reasons why legionnaire's disease was unknown before 1976.
- 17** **Propose** a definition for a non-infectious disease.

4.2 INVESTIGATING

e-xploring

Complete the following activities and find out more about diseases by connecting to the **Science Focus 4 Second Edition Student Lounge** for a list of web destinations.



- Carry out research to find an example of a virulent disease and a non-virulent disease. The outcome of each type of disease is very different. Write a report to demonstrate the difference. **L**
- Investigate** an outbreak that has occurred in Australia in the past five years. You could look at outbreaks of flu, legionnaire's or meningococcal disease. Present your data using a table. Write a conclusion on the cause of the outbreak and whether it is under control. **N**
- Choose a disease such as meningococcal disease that has occasional outbreaks in Australia. Research how many deaths have occurred each year in the past 10 years. Present your findings as a table and graph using an electronic spreadsheet such as MS Excel. **N**

4.2 PRACTICAL ACTIVITY

1 Survey of diseases

Aim

To survey the range of childhood diseases and medical conditions experienced by the class

Method

- Survey your class to find out how many students have had the following childhood diseases and medical conditions:
 - measles
 - mumps
 - rubella (German measles)
 - chickenpox
 - influenza (the flu)
 - a cold
 - bronchitis
 - food poisoning
 - a cut that became infected
 - acne
 - head lice

- Brainstorm which diseases members in the class have been vaccinated (immunised) against. This will often happen at school, although some vaccinations may have been carried out privately in preparation for a trip overseas or after an accident.

Questions

- Construct** a table showing the results from the survey of childhood diseases and conditions and another showing the results from the brainstorming of vaccinations/immunisations.
- Calculate** the percentage of class members that have contracted each childhood disease or medical condition.
- Construct** a bar graph to show these percentage results. **N**
- Propose** reasons why the government pays for all students to be vaccinated against different diseases.
- Propose** reasons why you are not vaccinated against the common cold.

context

One unprotected sneeze or cough can send thousands of individual bacteria or viruses into the air. These pathogens have direct access to another host if they are breathed in directly, or if they land on someone's food or on a bench where a hand is placed. Only a

few need to gain entry to infect the new host, making infectious diseases very easy to spread. Any disease that is transmitted easily from person to person is termed infectious or communicable.

Diseases caused by some micro-organisms

Not all micro-organisms are harmful to humans. Some are very helpful in that they serve as food sources or help to decompose wastes. Some help protect you from disease, while others aid your digestion. Only a few micro-organisms cause disease and these are known as **pathogens**. The main categories of pathogens are:

- bacteria
- viruses
- protozoa
- fungi.

Some infectious diseases and the micro-organisms that cause them are shown in the table on page 136.

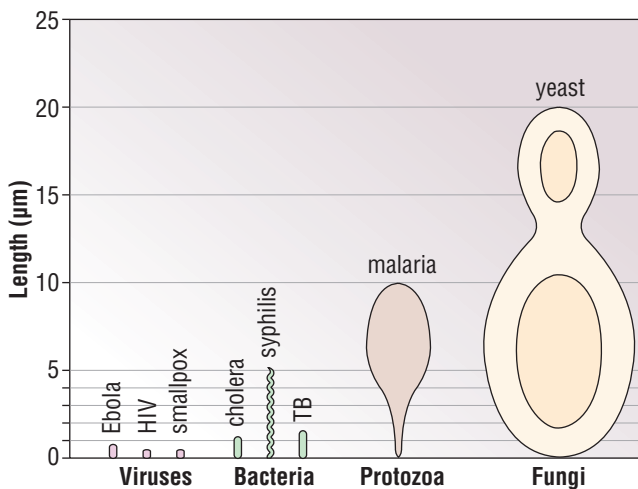

Fig 4.3.2 While some fungi can be seen with the naked eye, protists and bacteria can only be seen with a microscope. Viruses are so small that an electron microscope is needed to see them.



Fig 4.3.1 An unprotected sneeze spreads bacteria and virus particles far and wide and spreads disease.

Science Fact File

Plague

The *Yersinia pestis* bacterium (formerly called *Pasteurella pestis*) is the pathogen responsible for bubonic plague—the Black Death. Between 1347 and 1352, an outbreak of this disease killed a third of Europe's population—an estimated 25 million people! The bacteria were spread by the fleas on rats!

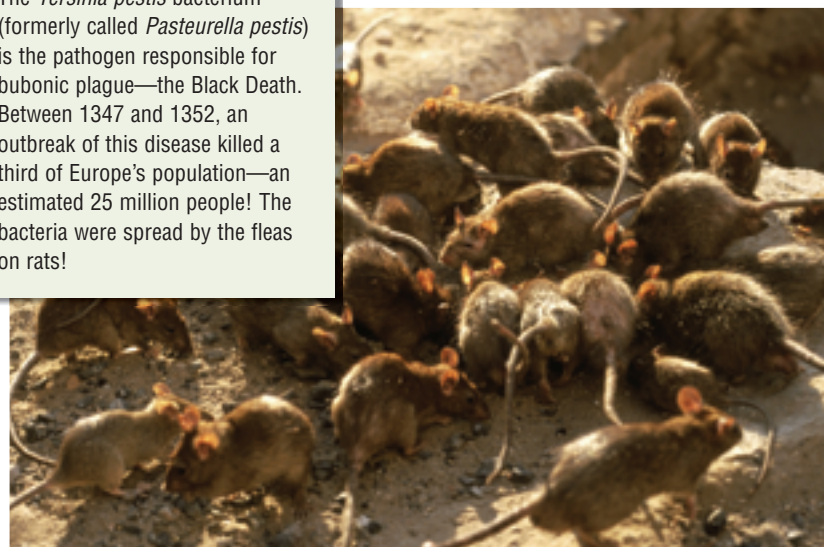

Fig 4.3.3 Bubonic plague is caused by bacteria carried by the fleas that live on rats. Bubonic plague outbreaks occasionally hit communities—even today.

Agent	Type	Disease cause	Symptoms
Rabies	Virus	Rabies	Paralysis, spasms, fever, overproduction of saliva
Varicella	Virus	Chickenpox	Fever, itchy blister-like rash
<i>Vibrio cholera</i>	Bacteria	Cholera	Diarrhoea, vomiting and dehydration
<i>Clostridium botulinum</i>	Bacteria	Food poisoning	Blurred vision, weakness, difficulty swallowing and occasionally death
<i>Giardia lamblia</i>	Protozoa	<i>Giardia</i>	Nausea, flatulence (farting), diarrhoea
<i>Toxoplasma gondii</i>	Protozoa	Toxoplasmosis	Acute form causes fever, chills, rash, exhaustion
<i>Candida albicans</i>	Fungi	Thrush	Creamy mucus, can be oral or vaginal
<i>Tinea corporis</i>	Fungi	Ringworm	Rounded areas of scaling on the body

Bacteria

Microscopic bacteria are around us all the time. There are about a billion in every teaspoonful of soil and there are probably more bacteria on your skin than there are people on Earth. Bacteria can multiply very quickly under the right conditions. When conditions are not favourable for growth, some types of bacteria form thick-walled spores that allow them to withstand cold, heat and prolonged drying. They can remain inactive in this form for days or even years, becoming activated once again when the conditions improve.

Many types of bacteria can be killed using penicillin and other antibiotics.







Type	Appearance	Examples
Cocci (singular: coccus)		Coccidiosis
Diplococcic		Gonorrhoea
Streptococci (chains)		Tonsillitis
Tetrads (groups of 4)		Sarcina
Clusters		Staphylococcus
Bacilli (rods)		Diphtheria, typhoid
Spirilla (spiral forms)		Syphilis



Figure 4.3.4 This is a SEM image of *Clostridium perfringens*. These rod-shaped bacilli bacteria are the cause of gas gangrene and food poisoning in humans.

Science Clip

Marianna Bridi da Costa hoped to represent Brazil in the Miss World contest in 2009 and had reached her country's finals. On 30 December 2008, her urinary tract became infected with the potentially fatal bacterium *Pseudomonas aeruginosa*. It spread quickly and soon cut off circulation to both hands and feet. These needed to be amputated. The infection continued to spread and Marianna died soon after.

Common shapes of bacteria

Shape is one characteristic that is used to identify **bacteria**: they can be rod-shaped (**bacilli**), spiral (**spirilla**) or spherical (**cocci**). All bacteria consist of only one cell but they can join together in pairs, chains or clusters.



Science Clip

Does your doctor wear a tie?

In 2004, Israeli researchers found that the neckties worn by doctors might transmit disease from one patient to another! A comparison of the ties worn in a New York hospital showed that doctors' ties were eight times more likely to be covered in disease-causing microbes than the ties worn by the security guards working there. Doctors' ties get sneezed on and coughed on many times each day. They then go home, but unlike all the other doctors' clothes, they rarely, if ever, get cleaned. They then go to work the next day, loaded with the microbes collected the day before. The doctors' ties are known as **fomites**, non-living materials that can transmit disease-causing bacteria.

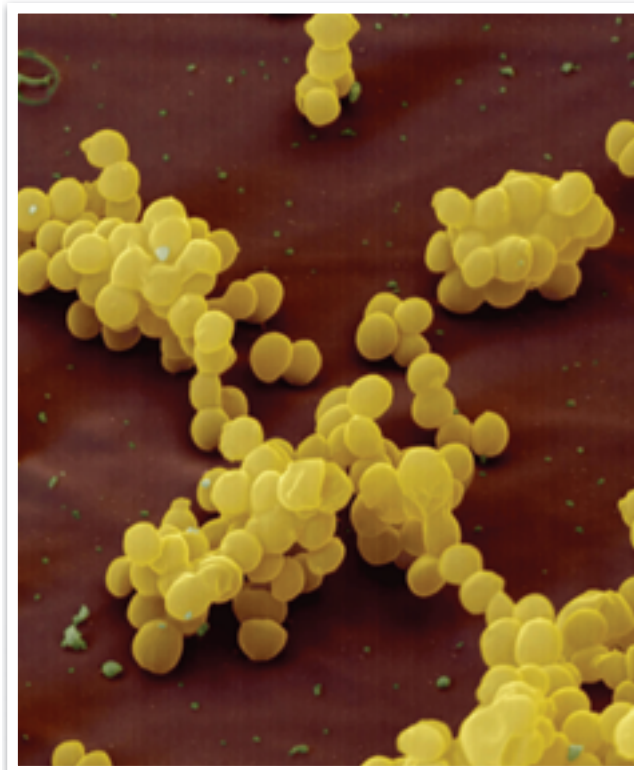

Fig 4.3.5 This is a SEM image of *Staphylococcus aureus*, the bacteria that lives on your skin and up your nose. This bacterium causes the pus in a pimple.

Viruses

Viruses are so small that they cannot even be seen with a 'normal' light microscope—they can only be seen with a much more powerful electron microscope. Viruses are not considered to be living things because they do not self-reproduce, grow, feed, grow or produce waste. They do move from place to place, but only if they hitch a ride on something, like other organisms, wind or water.

Viruses are parasitic invaders made of DNA (or a similar material called RNA) coated in protein. They attach themselves to a suitable host cell, enter it and take over. They hijack the cell, reprogramming it to make more virus particles. Eventually there are so many virus particles inside the cell that it bursts open, releasing the virus particles. These are then free to invade other cells.

Some viruses invade cells and remain dormant (inactive) for long periods of time. An example is the herpes simplex virus that is responsible for cold sores. Cold sores come and go, but the virus is always there in the infected person's body, waiting for the right conditions for rapid reproduction and 're-appearance'. Others do not kill the cell they infect, but re-program it in a way that causes it to become cancerous.

Science Clip

Hand-dryers versus towels

American researchers have found that using a hand-dryer increases the bacteria count on your hands by up to 255 per cent while paper towels and continuous loop cotton towels reduce bacteria counts by about half. The main reason is that most people do not keep their hands long enough under hand-dryers to completely dry them. They walk out of the toilet with hands that are still wet and many wipe them on their clothes to finish drying them. Bacteria also love the warm, moist atmosphere in the dryer and they get blown all over your freshly washed hands.

Unlike bacteria, viruses are not cells. They do not 'live' in the normal sense which makes them extremely difficult to 'kill'. Penicillin and other antibiotics have no effect on them. With most viral infections you have to wait until your body uses its own defence system to stop and kill the invading virus.



Fig 4.3.6 Shingles are caused by the herpes-zoster virus and cause blisters similar to cold sores.

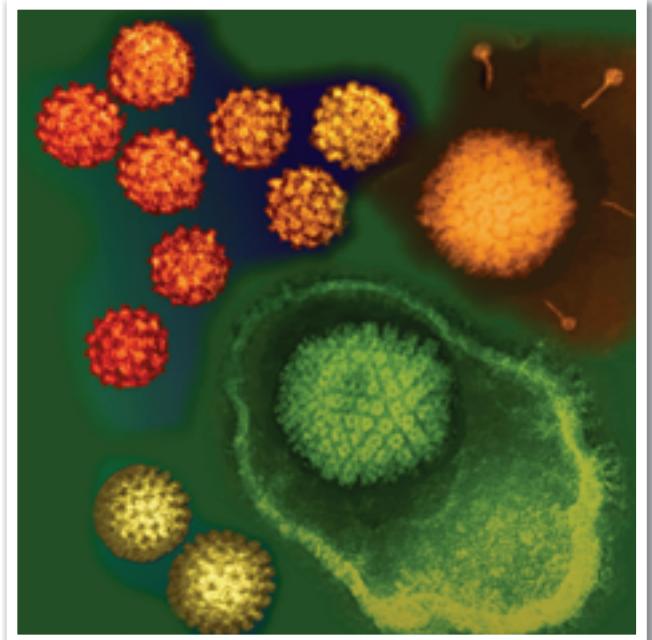

Fig 4.3.7 A collage of different viruses: papilloma (orange), rotaviruses (yellow) and herpes (green).

Science Fact File

Bird flu and interspecies diseases

Most pathogens are not able to jump from one species to another. This means that it is unlikely for pathogens and the diseases they carry to pass from animals to us—the worst you will probably ever get from them is fleas or worms.

Viruses mutate all the time and some viruses in animals have mutated into forms that allow them to transmit from animals to humans. Although these diseases are usually relatively harmless in animals, they are particularly dangerous to any humans that catch them. To us, they are 'new' diseases. Unlike the animals from which they jump, we have no natural immunity to them and so we cannot fight them off. HIV (the virus that causes AIDS) is thought to be a mutant form of a virus naturally occurring in chimpanzees that jumped species when humans in West Africa hunted and ate them. Likewise, there have been some instances of deadly pathogens jumping from rats to humans, from flying foxes to humans and even from racehorses to humans.

Until 1997, only birds were able to be infected with avian influenza A (H5N1), commonly known as bird flu. In that year it jumped to humans, killing six people in Hong Kong and hospitalising another 12. Although authorities killed about 1.5 million chickens in an effort to control the virus, it spread rapidly to the rest of the world in 2005–06, causing outbreaks in Asia, Africa and Europe.

Although the death toll from H5N1 is still not large, pathologists are extremely concerned that genes might swap between bird flu and human flu. This might happen if a person got infected with both diseases at the same time.

The new bug would then have the potential to be as deadly as bird flu, and as easy to catch as human flu. It could then bring us the next worldwide pandemic.

In early 2009, a new form of influenza, commonly referred to as swine flu, was discovered in Mexico. The new mutated virus (H1N1) spread rapidly, killing some of those infected. The potential danger of H1N1 reaching pandemic stage was so high that factories, businesses, schools and churches in Mexico were closed for many weeks. In Australia, to minimise its spread, all incoming airline passengers were scanned with thermal imaging cameras that would detect if they were experiencing flu-like fevers. The initial infections were concentrated in Melbourne, but the virus rapidly spread to all states.

Similar flu-based pandemics have occurred in the past:

- 1957–58, 'Asian flu' (A (H2N2)), caused about 70 000 deaths
- 1968–69, 'Hong Kong flu' (A (H3N2)), caused approximately 34 000 deaths. This virus still circulates today.

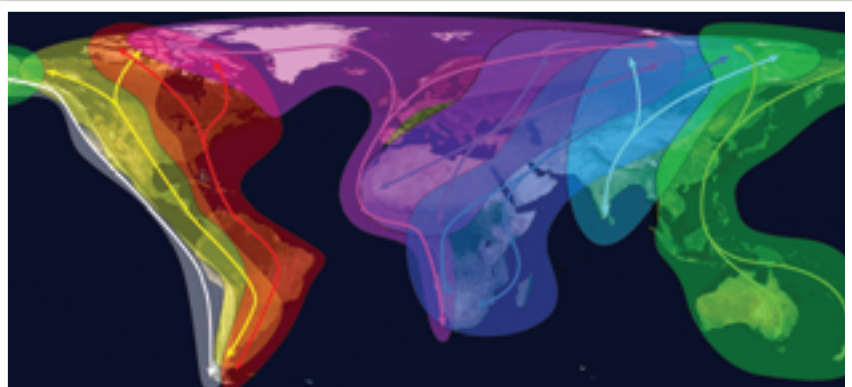

Fig 4.3.8 Migratory birds can spread bird flu just about anywhere on Earth.

Protozoa

Diseases caused by **protozoa** (sometimes called **protists**) are most often seen in tropical and subtropical areas. Like bacteria, protozoa are single-celled. Although most protozoa are harmless to humans, some parasitic types can cause serious illness. Protozoa sometimes form protective cysts around themselves if conditions are unfavourable, allowing them to survive between outbreaks. Examples of protozoa that cause disease are:

- *Giardia* and *Cryptosporidium*—these protozoa can contaminate water supplies.
- *Plasmodium*—several types of this parasitic protozoa live in red blood cells and liver cells, causing the common tropical disease, malaria. *Falciparum malaria*, the most dangerous type, is fatal in about 20 per cent of untreated cases. Initial infection occurs through a female *Anopheles* mosquito bite.

Fungi

Very few **fungi** cause disease in humans and those that do commonly invade the hair, skin and nails. Tinea (athlete's foot), ringworm and thrush are all opportunistic fungal infections.

Fungi are **opportunistic pathogens**. They are not usually associated with infection, but will take the opportunity to infect a person if the conditions are ideal or if the person's immune system is weakened. People can have lowered immunity due to a number of causes and all are more susceptible to these fungal infections. HIV/AIDS lowers immunity and so do the cancer treatments of chemotherapy and radiotherapy. After organ transplants, patients are given anti-rejection drugs that also lower immunity.

Diseases caused by macroscopic parasites

Parasites that can be seen without a microscope are known as **macroscopic** parasites.

Flukes

The most common type of disease-causing macroscopic parasite is the **flatworm**. Parasitic **flukes** are flatworms, and are best known for causing disease in many animals, including humans. Intestinal flukes, blood flukes, lung flukes and liver flukes all affect humans, causing serious damage to the organs they inhabit. This results in serious illness for their host. For example, blood flukes can damage blood vessels near major organs like the bladder and kidneys.



Fig 4.3.9 Thrush is an infection caused by a fungus. Severe thrush like this would normally only happen to those with weakened immune systems.

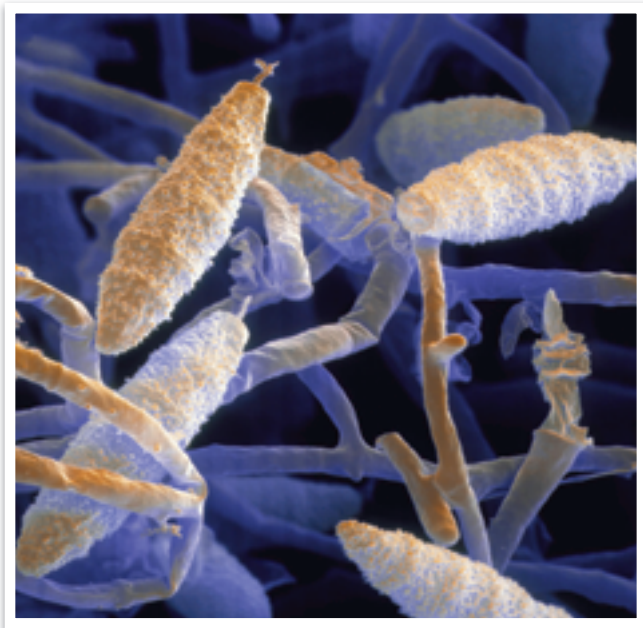

Fig 4.3.10 *Microsporium gypseum* is the fungus that causes ringworm on the scalp and body.

Tapeworm

Another type of flatworm is the **tapeworm**, which can sometimes live in human intestines. One type of tapeworm causes hydatid disease. If the eggs of this type of tapeworm are swallowed by humans, the tiny embryos will hatch from the eggs and move from the intestines into the bloodstream. Cysts develop wherever the embryos end up, most often in the liver. Here they are capable of killing the host.

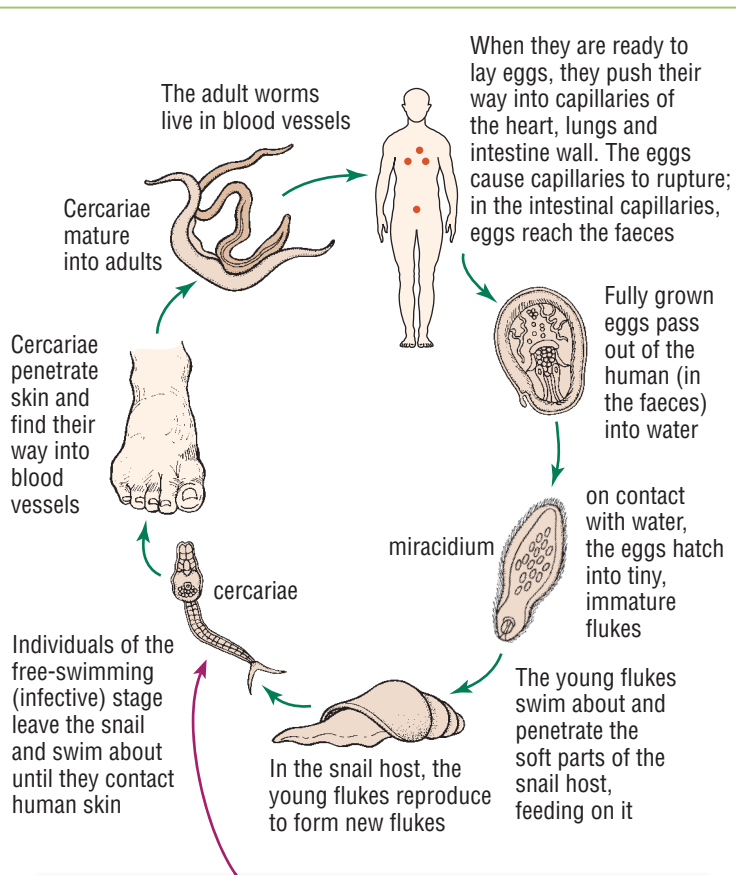

Fig 4.3.11 The life cycle of the parasitic blood fluke and a microscopic image

Worksheet 4.3 Infections



Fig 4.3.12 This parasitic tapeworm can live in the intestines.



Fig 4.3.13 Elephantiasis is caused by parasitic worms blocking the lymph nodes which is part of the body's natural drainage system. Mosquitoes bite an infected person taking a little of their blood which also carries larvae of the worm. They then inject the larvae into the bloodstream of another victim. Elephantiasis is endemic to parts of Africa and Asia.

4.3 QUESTIONS

Remembering

- 1 **List** the four types of pathogens responsible for infectious disease.
- 2 **Name** the three common shapes found in bacteria and draw an example of each.
- 3 **List** the symptoms of:
 - a rabies
 - b giardia
 - c tinea
- 4 **List** three examples of macroscopic parasites.

Understanding

- 5 **Define** the term pathogen.
- 6 **Outline** two reasons why viruses cannot be considered to be living things.
- 7 **Describe** what viruses do to cells.
- 8 **Clarify** what is meant by the term *protozoa*.
- 9 **Explain** what an opportunistic pathogen is.
- 10 **Explain** what is meant by the term *macroscopic parasite*.
- 11 Hydatid disease can cause death in humans. **Explain** how this may occur.
- 12 Copy the following statements and **modify** them to make them correct.
 - a Spherical bacteria are called spirilla.
 - b Viruses are larger than bacteria.
 - c Many fungi cause disease in humans.
 - d Parasites always kill their hosts.
- 13 **Describe** how bacteria and protozoa protect themselves in unfavourable conditions.

Applying

- 14 **Name** the pathogen that causes each of the following diseases and identify what type of pathogen it is:
 - a Black Death/bubonic plague
 - b cholera
 - c giardia

- d ringworm
- e pimples
- f bird flu
- g Hong Kong flu
- h malaria

Analysing

- 15 **Analyse** what is happening in the life cycle of a blood fluke as shown in Figure 4.3.11. Use a series of dot points to describe what is happening.

Evaluating



- 16 **Contrast** an endemic disease with an epidemic.
- 17 **Distinguish** between macroscopic and microscopic.
- 18 Imagine you are about to go travelling in tropical regions. How do you **propose** to protect yourself from malaria?
- 19 **Propose** ways in which an infestation of tapeworms could cause malnutrition.
- 20 **Propose** some precautions you could take to avoid becoming infected with blood flukes.
- 21 **Propose** reasons why:
 - a it is important to describe all your symptoms to your doctor when you are sick
 - b malaria is more common in tropical regions
 - c many more diseases are caused by bacteria than by fungi
 - d you should be careful when cleaning up after your pet dog, cat or bird
 - e raw or nearly raw meat can be dangerous to your health

Creating

- 22 Imagine that a parasite, *Cowium*, lives mainly in cows. *Cowium* eggs are present in the cow's milk. If the milk is not treated before drinking, humans become infected. Once inside the infected person, the eggs become mature worms and live in the intestines. They cause severe digestive problems and malnutrition. **Construct** a diagram that **outlines** the life cycle of *Cowium*.

4.3 INVESTIGATING

Investigate your available resources (for example, textbooks, encyclopaedias, internet) to complete the following tasks.

- 1 Find out about the three ways of preserving food (dehydration, canning and radiation).
 - a Research what is done in each process.
 - b Describe how each method kills or slows down the growth of microbes.
 - c Evaluate each method in terms of effectiveness and safety.
 - d Recommend the best method for preserving the following foods: tomatoes, grapes, meat, peanuts. Justify your answer in each case.
- 2 Find out about the most serious outbreak of the bubonic plague that occurred in Europe between 1347 and 1352.
 - a Conduct research to find out if this disease exists today.
 - b Present a timeline of dates for major outbreaks since 1352. 
- 3 Research different types of malaria.
 - a List the symptoms of each type.
 - b Construct two scenarios, with symptoms as clues to the type of malaria.
 - c Present the case studies you researched as written information so that another student can identify the type of malaria. 

Reviewing: *Outbreak*

Outbreak (1995) (M rating) is a film about the transmission of disease from animal to human, creating a pandemic. Watch *Outbreak* and prepare a film review about it. In your review you must:

- state details about its length, leading actors, director, producer, studio and year of production

- state what animal the disease 'jumped' from
- state whether the disease was caused by bacteria, viruses, protozoa, fungi etc.
- classify the disease as infectious or non-infectious
- list the symptoms of the disease
- state the prognosis (i.e. outcomes) of the disease
- describe how authorities initially controlled its spread
- describe how authorities intended to 'kill' the disease
- assess how realistic the film is in these days of bird flu
- assess how accurate the science is in the film
- identify which terms are used incorrectly in the film.



Present your review in one of the following ways: 

- an interview with the director, leading actor or the pathologist advising the director
- a segment for a TV program such as *ET*, *At the Movies* or *The Movie Show*
- a single page spread for an entertainment magazine or for a movie guide such as *TV Week*.

e-xploring



Visit the Infection Detection Protection website by connecting to **Science Focus 4 Second Edition Student Lounge** and complete the following activities.

- Play the game 'Bacteria in the Cafeteria'. Use your findings to construct a poster that can be placed in your school cafeteria to keep it safe from disease. 
- Play the 'Infection' game and construct a leaflet that could be used in a doctor's waiting room to protect people from disease. 

4.3 PRACTICAL ACTIVITIES



Making yoghurt

Aim

To produce yoghurt using bacteria

Note: This Prac involves observations over several days.



Safety

It will be unsafe to eat the yoghurt produced from this Prac if the utensils being used have not been sterilised.

Equipment

- 250 mL beaker
- spoon
- plastic cling wrap
- 1 cup new UHT milk
- 1 large spoon of natural yoghurt with live bacteria
- incubator

Method

- 1 Half fill the beaker with milk.
- 2 Stir in the yoghurt. This will start the process.
- 3 Cover the beaker with cling wrap and place in the incubator at 40°C.
- 4 Record any changes in its smell and consistency over the next few days.

Questions

- 1 **Explain** why you needed to add yoghurt to start the process.
- 2 **Explain** why the mixture was left at this particular temperature.
- 3 **Describe** the changes in the mixture over three days.

2 Micro-organisms around you

Aim

To grow a variety of microbes on nutrient agar

Equipment

- 5 Petri dishes containing nutrient agar (agar plates)
- wire loops
- heat-proof mat
- Bunsen burner
- masking tape
- gloves

Method

- 1 Tape one agar plate closed, label it and put it aside. This will be the control.
- 2 Take another agar plate and expose it to the air. Each group should sample the air in different locations: for example, the toilets, corridor or classroom. Seal your agar plate and label it.
- 3 Light the Bunsen burner and heat the wire loop to sterilise it.
- 4 Carefully touch the wire loop to a 'dirty' surface, then brush it lightly over the surface of the agar of a new plate. Each group should sample a different surface.
- 5 Seal and label your plate.

- 6 Put all your plates, including the control, in a warm place for 48 hours.



Safety

Caution: do not open the Petri dishes once they are sealed. Look at them through the lids.

- 7 Without untaping the lids, examine and note the numbers and types of colonies that have grown on your agar plate. Fungal colonies appear fuzzy, while bacterial colonies are smooth.
- 8 Dispose of the Petri dishes according to your teacher's instructions.

Questions

- 1 **Explain** the use of a control in this experiment.
- 2 **Compare** your results with those of your classmates.
- 3 **Construct** a table of the class results. Include the different colours and shapes of the colonies formed.
- 4 **Evaluate** which locations have the greatest numbers of micro-organisms present.
- 5 **Contrast** a fungal and a bacterial colony.

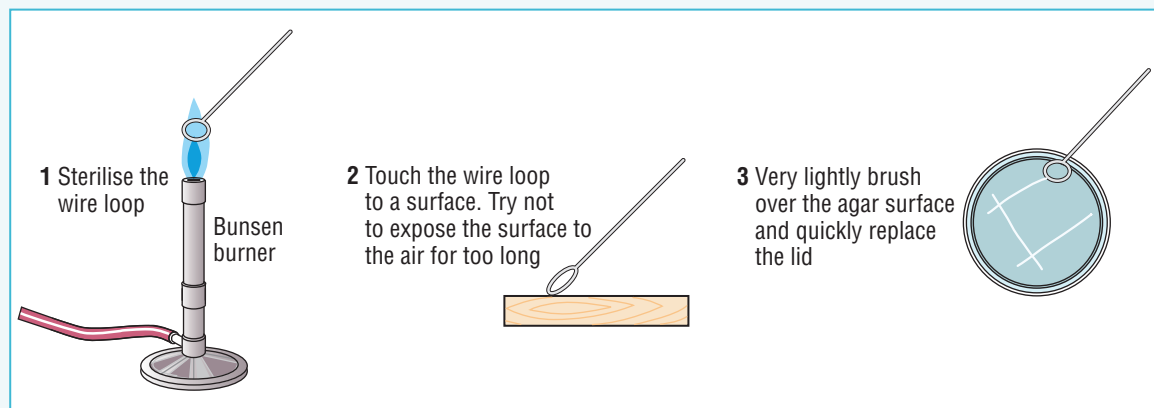

Fig 4.3.14

Unit 4.4

Transmission and control of infectious diseases

context

You will have had a cold at some time in your life. You may even have contracted diseases such as chicken pox, measles or the flu. These diseases are infectious diseases: you caught them from

someone or something but you also got over them. Your body fought the disease and won, perhaps with the help of drugs such as antibiotics. You are protected from catching other diseases because you have been vaccinated against them.



Fig 4.4.1 Head lice are easily transmitted directly from person to person. Luckily they are just as easily controlled. This SEM image shows a single head louse and its egg attached to a hair.



Fig 4.4.2 Mosquitoes carry blood from person to person and so indirectly transmit diseases such as malaria, dengue fever and elephantiasis. They are an example of a vector.

Pass it on

Infectious diseases can be passed on by direct or indirect transmission.

- **Direct transmission** happens through direct contact with the infected person or by contact with droplets of body fluid. Diseases transmitted by direct contact are called **contagious diseases**.
- **Indirect transmission** occurs through an intermediary agent like an insect, air or contaminated water. Carriers of disease are called **vectors**. A mosquito that carries malaria from person to person is an example of a vector.

Natural control

Your body has several mechanisms for coping with disease.

The skin

The first line of defence is the outer layer of your skin and the bacteria it carries. Your skin is constantly dying and you are constantly shedding its dead cells. Harmful pathogens will often fall off with them. There are also good bacteria on your skin which compete with the invading pathogens, preventing them from reproducing.

Pus

The second line of defence is **leucocytes** (white blood cells) which are able to destroy some pathogens. They travel in the blood to the site of infection, converge on the pathogens, digest them and engulf their remains. Dead micro-organisms and dead white cells are left behind, forming a yellowish discharge called **pus**.



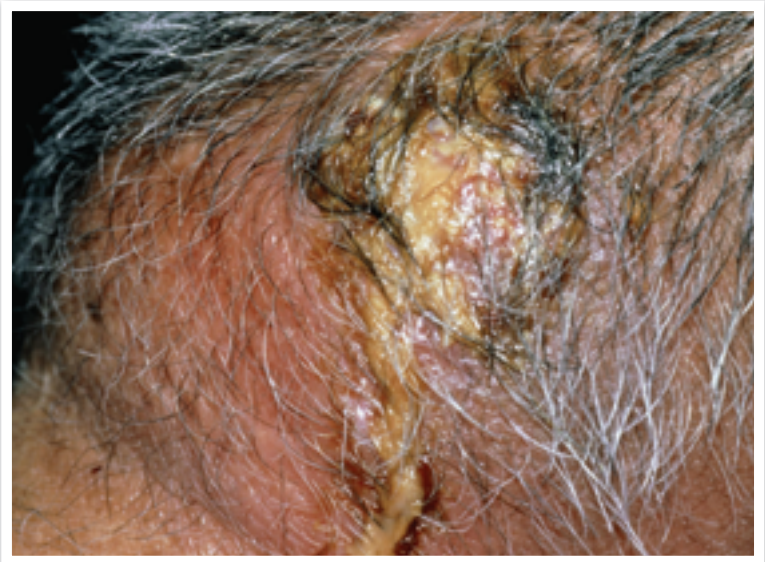

Fig 4.4.3 A carbuncle full of pus on the back of a patient's neck. A carbuncle is a series of interconnected boils, which are really just deep pimples at the base of a hair or sweat gland. The pus is an indication that the body is at war.

Acquired immunity

The third line of defence is a process called **acquired immunity**. In this process, your body responds to any foreign invasion by producing special chemicals called **antibodies**. A foreign substance which triggers the production of antibodies is known as an **antigen**. The antibody disables the antigen, reducing its effect or allowing it to be easily consumed by white blood cells.

There are many different forms of antibodies and a particular antibody will only act against the antigen it has responded to. Your body can continue to produce that type of antibody long after the antigen has been destroyed. You will then be **immune** to that particular antigen as long as its specific antibodies are present in your body.

Imagine you contract measles. Having never had measles before, you have no antibodies to fight the disease. Your **immune system** will then go to work producing antibodies, although not yet in sufficient numbers to fight the rapidly growing number of measles viruses in your body. You feel very sick until there are sufficient antibodies to win the 'war'. These antibodies allowed you to recover and will protect you from measles in the future.

Unfortunately they cannot protect you from chickenpox or any other disease-causing pathogens: they need different antibodies.

If you caught a cold last year then your immune system built the antibodies required to fight it, allowing you to eventually recover. Unfortunately the cold virus



Fig 4.4.4 Mumps are caused by a virus. Their most obvious symptom is swelling. Once you have the mumps it is unlikely you will catch it again.

mutates quickly into new but similar forms. The antibodies that you built last year are not effective against this year's strain and so you can get sick once more. Influenza is another virus that mutates quickly into new forms. Hence, you can catch a slightly different version of flu year after year.

Your body will always try to protect itself from disease and will attempt to destroy any pathogen that enters it. This relies on a healthy immune system. However, the function of your immune system can be lowered. Some factors that can lower the function of your immune system are:

- poor diet
- alcohol or drug use
- stress
- a lack of sleep
- diseases such as HIV/AIDS
- chemotherapy and/or radiotherapy used to treat cancers
- anti-rejection drugs used after organ transplants.

Science Fact File

Relief from influenza

Although the flu virus keeps mutating into new forms, there is always a part that stays unaltered. A drug called Relenza™ attacks that part allowing it to fight every strain of flu that has existed over the last century. Developed in Australia, Relenza™ is extremely effective and may be the only way of fighting a bird flu pandemic.

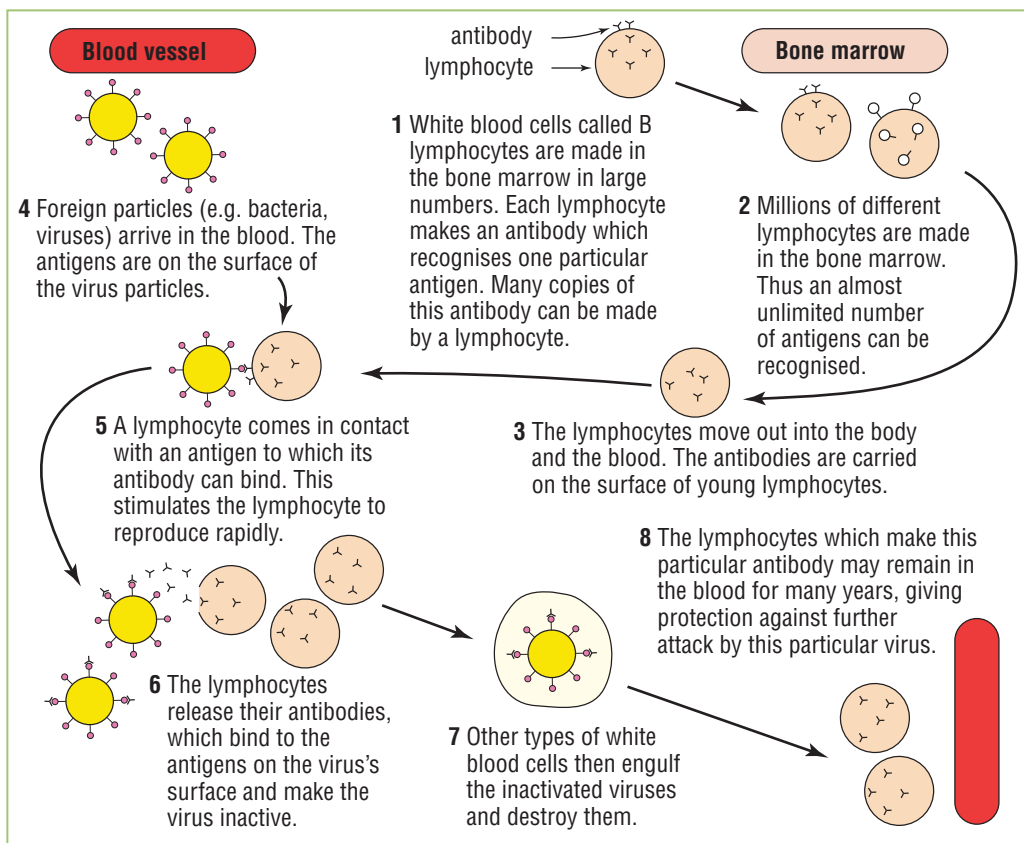

Fig 4.4.5 The process of acquired immunity

Artificial control

Good nutrition, clean water and adequate sleep and exercise will give you a degree of natural protection from disease. Some diseases, however, are so dangerous that additional and artificial protection is required.

Vaccinations

The threat from many of the killer diseases of the past has been greatly reduced, and sometimes eliminated, by the development of **vaccines**. You can be immunised against many diseases by being inoculated or **vaccinated** with a vaccine, usually by injection.

Vaccines can be used against both bacterial and viral diseases. Children in Australia are routinely vaccinated against diseases such as tetanus, measles and chickenpox. Polio is a crippling and often paralysing disease that caused epidemics in Australia in 1938, 1956 and 1961–62. There have been no cases of polio since 1977, largely due to mass vaccination.

Some parents choose not to immunise their children through fear of relatively rare side-effects. All children, for example, were once vaccinated with the Sabin polio vaccine, a sweet and sticky syrup that was not injected but sipped. Although effective, this vaccine caused paralysis in one in every 2.4 million people. For this

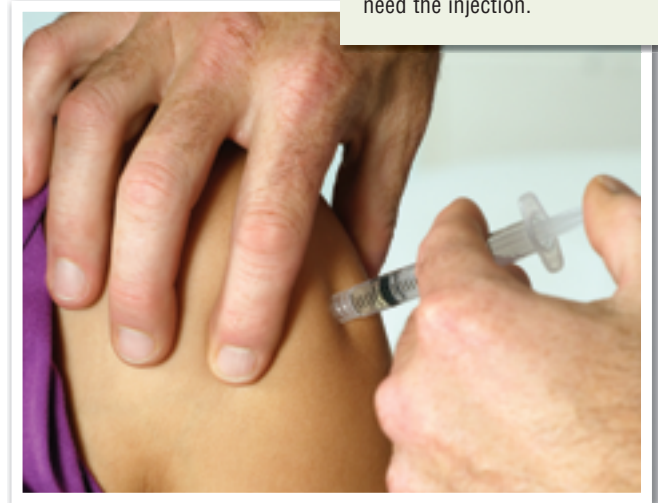

Fig 4.4.6 Vaccines stimulate the immune system into building antibodies that fight an infection before it can take hold in your body. They are often the only defence you have from deadly or disfiguring diseases such as polio, hepatitis and tetanus.

reason, some parents were wary of having their children vaccinated with it (Sabin has since been replaced with an even safer vaccine known as IPV). Although expensive, mass immunisation programs are extremely cost-effective: it is estimated that for every dollar spent on immunisation programs, four dollars are saved in public health costs.

Science Clip

Sexist vaccinations

Girls are commonly vaccinated against rubella but boys are not. Although rubella is a nasty disease for anyone, it is particularly dangerous if a woman contracts it during pregnancy as rubella often causes abnormalities in the foetus. Since 2007, all girls have been given the opportunity to be immunised against human papilloma virus (HPV) which is known to cause 70 per cent of cancers of the cervix. Boys don't have a cervix and therefore don't need the injection.

Immunity

Two types of immunity can be produced by vaccines.

- **Active immunity:** this stimulates the body into making its own antibodies and usually involves injecting a live but disabled version of the virus or bacteria. The Sabin polio vaccine, for example, uses a live but non-contagious strain of the disease. The deadly disease smallpox has been effectively eliminated worldwide by widespread vaccination using a vaccine made from less harmful cow pox—a virus very similar to smallpox. The body's immune system is 'bluffed' into producing antibodies for the actual disease. These vaccines may cause some of the milder symptoms of the disease to appear, but will protect the person from a serious attack.
- **Passive immunity:** this involves injecting a vaccine with antibodies produced previously by another organism such as a horse. This gives quick immunity and is good in emergency situations, such as when health workers move into areas hit by an epidemic or when someone is bitten by a snake.

Passive immunity does not last as long as active immunity. Even active immunity does not last forever. Production of antibodies can reduce with time and a **booster shot** (re-injection with the vaccine) may be needed. It is recommended, for example, that tetanus booster shots be given every 10 years.

The problem with viruses

Viruses multiply so rapidly that new strains are appearing all the time. They are also incredibly small, making them difficult to isolate in the laboratory. These two factors make it extremely difficult to develop effective vaccines against them. Although some drugs are effective in reducing the effects of a virus, as yet, no chemicals can eradicate a viral infection. AZT, for example, is a drug used to treat patients with HIV/AIDS. Not all patients respond to AZT, however, and it does not kill the virus.

Antibiotics

Antibiotics are drugs that are able to selectively kill off certain pathogens while leaving the patient's own body cells intact. Although antibiotics can fight many bacterial infections, they are completely ineffective against viruses which are far too protected while residing inside the body cells.

Science Clip

Ancient vaccination

The earliest evidence of vaccinations goes back to around 500 BCE. Chinese physicians noted that exposing healthy people to particles from smallpox scars gave them a milder form of the disease. This protected them from the more serious form. Only four per cent died from this procedure—a phenomenal success rate for that era!

Science Fact File

The first successful vaccination

In 1796, the English physician Edward Jenner (1749–1823) noticed that milkmaids rarely contracted the deadly disease smallpox. He hypothesised that this was because most had been infected with a similar, milder disease of cows known as cowpox.

Jenner met James Phipps, an eight-year-old boy whose family was dying of smallpox. Jenner exposed James first to cowpox and later to smallpox. The boy survived. From 1798, widespread vaccinations in Great Britain and the USA began and Jenner predicted that smallpox would eventually be completely eradicated. Nearly 300 years later, the World Health Organization (WHO) started a program of worldwide smallpox vaccination. It is estimated that smallpox killed 500 million people worldwide during the twentieth century, ending in 1977 when the last case of naturally transmitted smallpox was reported in Africa. In 1980, the WHO officially announced the end of smallpox. Two stocks of the virus remain in high-security laboratories in the USA and Russia.

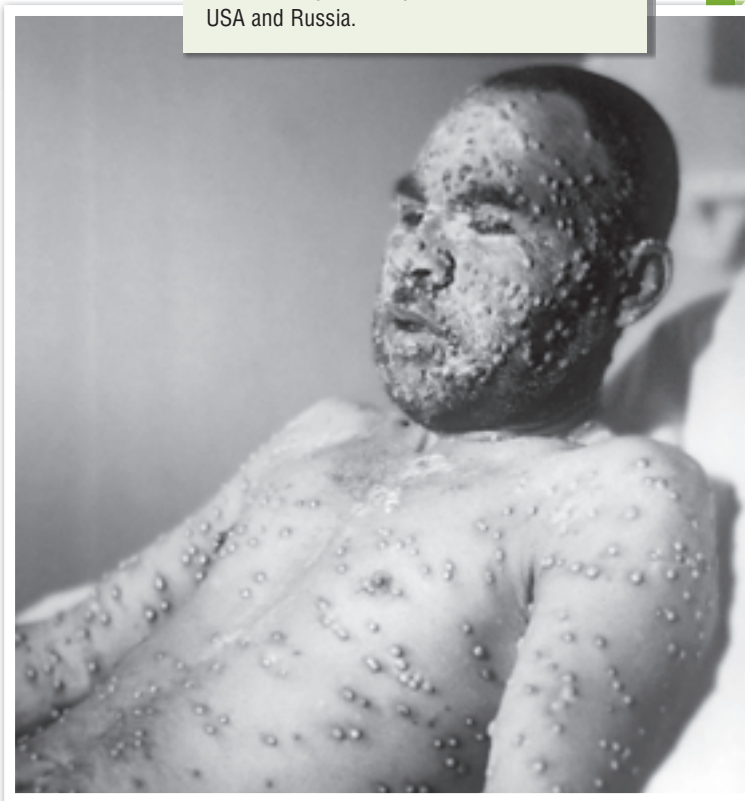

Fig 4.4.7 This man has smallpox. The 'pox' are the pus-filled blisters that cover his face and body. Between 20 and 40 per cent of victims died if they contracted the disease. Those who survived were sometimes left blind and always with bad scarring. Fortunately, vaccination has wiped this horrific and highly infectious viral disease from the planet.



Fig 4.4.8 Penicillin is just one of many different antibiotics available to fight bacterial infections.

Antibiotic resistance

The overuse of antibiotics has led to the development of antibiotic-resistant strains of bacteria. The more antibiotics are used, the faster these resistant strains emerge. It takes up to 20 years to develop new drugs and it is likely that doctors might soon be left without any drugs to fight the new, developing strains. Particularly worrying is the recent rise of drug-resistant and deadly tuberculosis. This form of TB seems to have originated in the overcrowded jails of Russia. Prisoners often did

not complete the prescribed course of antibiotics, leading to the development of 'super-TB'. This TB has recently appeared in New York, United States, and there is no effective way of treating it.

Unless the infection is severe, it is best to let your body recover naturally. If you are prescribed antibiotics, make sure you complete the course set by your doctor.



Science Fact File

Joseph Lister

Joseph Lister (1827–1912) was an outstanding student and graduated from University College, London in 1852 with an honours degree in medicine. In 1861 he became surgeon at the Glasgow Royal Infirmary. At that time, almost half of the patients undergoing surgery died of a post-operative wound sepsis infection, known then as 'hospital disease'.

In 1865 Louis Pasteur found that decay was caused by fermentation when living matter in the air entered the body. Lister made the connection between Pasteur's ideas and wound infection. Knowing that carbolic acid was being used for the treatment of sewage, he began cleaning wounds and dressing them with a solution of carbolic acid. Soon his wards were completely free of wound sepsis. It was not long before Lister's antiseptic methods were used worldwide, saving countless lives.

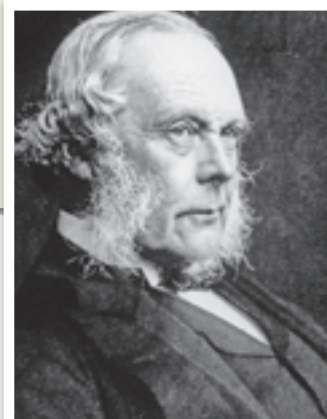

Fig 4.4.10 Joseph Lister

Science Clip

Super-croc!

Despite living in dirty water, crocodiles rarely get infection from the injuries they receive from other crocs. In contrast, similar wounds in humans would quickly become infected and probably lead to blood poisoning and death from septicaemia. Scientists have isolated an antibody in the blood of crocodiles in the Northern Territory that seems to keep them infection-free. It is hoped that this antibody might lead to the development of new and powerful antibiotics for human use.



Fig 4.4.9 Antibodies seem to keep crocodiles infection-free, despite them living in dirty water.

Science Clip

Joseph Lister's water

Ever gargled with the antiseptic mouthwash Listerine? Listerine is named after Joseph Lister.



Case study

HIV/AIDS

AIDS stands for Acquired Immune Deficiency Syndrome. It is a condition caused by infection with the virus known as **HIV**—Human Immunodeficiency Virus.

Where did it come from?

The earliest known sample of HIV in a blood sample was collected in 1959 from a man suffering from a mysterious disease in the African city of Kinshasa in the Democratic Republic of Congo. It was not until 1999 however that researchers discovered the origins of HIV-1, the main strain of HIV. The virus is thought to have moved into the human population via the following steps.

Step 1

Monkeys carry their own version of HIV, called SIV (simian immunodeficiency virus) but are usually immune from it, suffering little if any illness.

Step 2

HIV-1 seems to have emerged through a combination of two of these monkey viruses.

Step 3

Chimpanzees acquired the disease from eating infected monkeys.

Step 4

Hunters were exposed to infected chimp blood via a scratch or by eating infected chimp meat.

What does it do?

HIV is a type of **retrovirus**. These viruses incorporate their DNA into the host cell's DNA. This means that when the host cell reproduces, the virus is also replicated. The HIV retrovirus is unusual because it invades T4 leucocyte white blood cells, the very cells that protect your body from disease. This invasion leaves the body vulnerable to other diseases. It is these other diseases that make up AIDS.

Symptoms

Many people infected with HIV develop symptoms of a viral illness within a few weeks, much like the flu, although these symptoms soon disappear. It can take many years before AIDS develops, and a small percentage of people who test positive to HIV never develop AIDS.

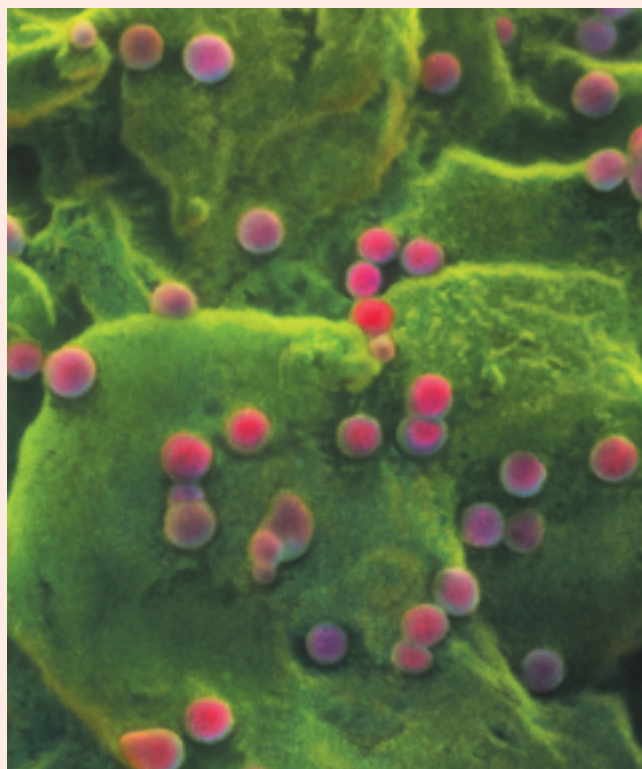

Fig 4.4.11 The surface of a T cell (green) infected with HIV (red), the agent that causes AIDS

Science Fact File**HIV/AIDS statistics**

The most recent United Nations report on HIV/AIDS (2007) states that:

- 30 to 36 million people are currently living with HIV/AIDS
- 2.5 to 4.1 million people were infected in that year
- 1.9 to 2.4 million people died from it that year
- more than 30 million people have died from it since the epidemic was first identified in the early 1980s.

Science Clip**Did scientists create AIDS?**

Some scientists think that infected monkey kidneys were used in the development of a polio vaccine called CHAT. Polio was devastating the world in the 1950s and the experimental CHAT vaccine was given to thousands of people in Africa between 1957 and 1960. The first outbreaks of AIDS were in the same region the vaccine was given, the first death being in 1959. Did the CHAT vaccine cause the AIDS outbreak?



Fig 4.4.12 Kaposi's sarcoma is a common symptom of AIDS.



Figure 4.4.13 A newborn receives a dose of the anti-retroviral drug nevirapine moments after her birth. This drug dramatically reduces the risk of HIV transmission through breastfeeding during the first six weeks of her life from her HIV+ mother. However, if infection does occur, it will most likely be from strains resistant to nevirapine, making HIV much harder to treat early with nevirapine.

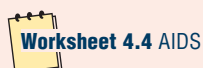

Worksheet 4.4 AIDS

Early signs of HIV infection are night sweats, fever, swelling of lymph nodes, fatigue, unexpected weight loss and concentration problems. AIDS is not really a defined disease. Rather, it is a collection of symptoms caused by **opportunistic infections** that have thrived due to the sufferer's struggling immune system. Although symptoms vary from patient to patient, commonly they include: purple markings on the face (Kaposi's sarcoma, a type of skin cancer), diarrhoea, fungal infections such as thrush of the mouth and skin, bleeding, bruises, dementia and an extreme form of pneumonia.

Diagnosis

The lack of symptoms means a person with HIV can look healthy for years. In many cases they may not know they are infected. This makes it impossible to tell who has and who has not got the infection. A simple blood test can, however, determine if a person is infected with HIV, regardless of how healthy they appear on the outside. This test detects if there are any HIV antibodies present. If there are, then the person is HIV+. If not, they are HIV-.

Transmission

Although the virus is present in all the bodily fluids of an infected person, fluids such as saliva, tears, breast milk and sweat are considered 'safe' as the concentration of the virus in them is very low. In contrast, blood, semen and vaginal fluid have high concentrations of the virus and so pose the greatest risk of transmission. Sexual contact and the sharing of drug-injecting equipment are the most common means of HIV transmission. HIV can also be transmitted through blood transfusions or blood products. This is now extremely rare in Western countries such as Australia, due to rigorous screening procedures in blood banks. The virus can also be passed from mother to child in the womb.

Treatment

There is currently no cure or vaccination for HIV/AIDS. Ongoing research means that treatments for HIV/AIDS sufferers are improving all the time. One major advance is the development of azidothymidine, known as AZT. It prevents new HIV particles being correctly made in cells. It cannot cure the disease, but improves health and adds one to two years of quality life to about 60 per cent of AIDS patients. The main problem with AZT is that it is extremely expensive, has unpleasant side-effects and is not effective in all patients.

Prevention

To avoid HIV, you need to avoid contact with bodily fluids, particularly blood, semen and vaginal fluids. This means that you need to ensure:

- condoms are always used correctly during sexual intercourse—condoms do, however, have a five to ten per cent failure rate and other forms of contraception give no protection against HIV
- all needles and equipment that might draw blood are new or sterilised before use. Clean needles are vital when injecting drugs, getting a tattoo or body piercing
- rubber gloves are used when treating someone who is bleeding
- bleeding players leave the sportsfield.

Science Clip

HIV but no AIDS!

Not all HIV-infected people develop AIDS. A few remain symptom-free long after the time when AIDS would normally have developed. Everyone has human leucocyte antigen (HLA) proteins in their bodies that attach to virus fragments in infected cells and destroy the cell. Some types of HLA proteins are better at attaching themselves to certain viruses than other HLA proteins. It is currently thought that those HIV-infected people who do not develop AIDS have a special type of HLA protein in their bodies which is good at killing HIV-infected cells.



Fig 4.4.14 Condoms are the only contraceptive device that gives protection from HIV.

4.4 QUESTIONS

Remembering

- 1 State** another name for:
 - a diseases transmitted by direct contact
 - b white blood cells
- 2 List** three:
 - a diseases that children are vaccinated against
 - b factors that will boost your natural immunity
 - c factors that might lower natural immunity
- 3 Specify** what makes up pus.
- 4 Indirect** transmission needs an agent or vector to carry the disease. **Name** one vector and the disease it carries.
- 5 Specify** what the acronyms HIV/AIDS stand for.

Understanding

- 6 Describe** how HIV can be passed from person to person.
- 7 Explain** how the following protects you from disease:
 - a the skin
 - b leucocytes
- 8 Explain** why antibiotics are ineffective against viruses.
- 9 Explain** why you are unlikely to get measles twice.
- 10 Outline** how a vaccine is used to protect against disease.
- 11 Explain** why you will probably catch a cold this year even though you had a cold last year and got over it.
- 12 Explain** why there is still no vaccination to protect you from the common cold.

13 Describe in words what Figure 4.4.15 is showing.

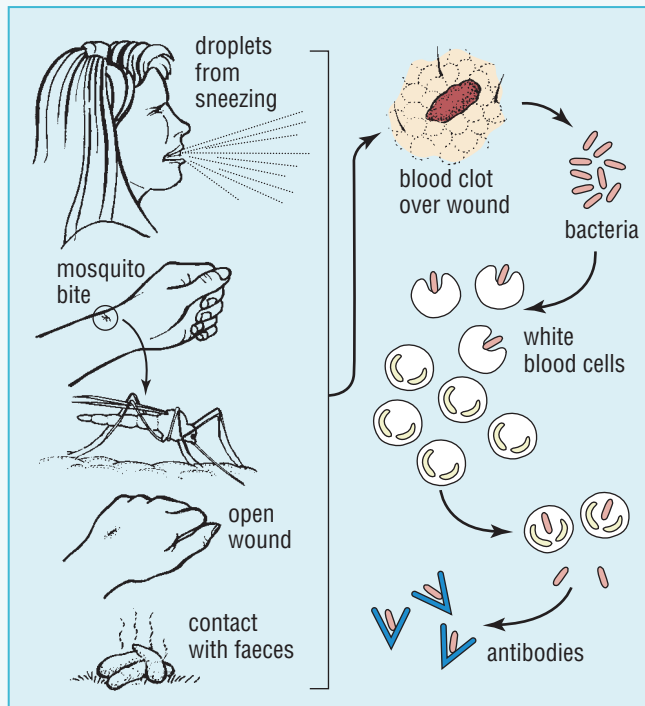

Fig 4.4.15

Applying

- 14 Identify** whether the following diseases are caused by direct or indirect transmission:
- chickenpox
 - malaria
 - elephantiasis
 - the common cold

Analysing

- 15 Distinguish** between:
- direct and indirect transmission
 - bacteria and viruses
 - antigens and antibodies
 - active and passive immunity
- 16** *The overuse of antibiotics is dangerous. Discuss* this statement.

Evaluating

- 17** Small children tend to get sick a lot. **Propose** reasons why.
- 18** **Propose** reasons why people who are already ill with one disease often catch other diseases.
- 19** HIV infection rates have increased in recent years because some people are taking more risks when having sex. One reason suggested is the success of AZT and other anti-viral drugs in fighting the disease.
- Propose** a way these two facts might be connected.
 - Explain** why unsafe sex is still foolish and dangerous.
- 20** **Propose** reasons why AIDS is spreading so quickly in developing countries.
- 21** HIV/AIDS is currently devastating the African continent, with up to 40 per cent of the population in some countries being HIV+. **Discuss** some of the likely effects that HIV/AIDS may have in these countries.
- 22** It could be said that no one has ever died of AIDS. **Propose** then what has killed those people who have died after being infected with HIV.

Creating

- 23** **Construct** a diagram to demonstrate what is meant by the *third line of defence*.

4.4 INVESTIGATING

Investigate your available resources (for example, textbooks, encyclopaedias, internet) to complete the following tasks.

- Research the arguments for and against vaccination and answer the following questions.
 - Discuss the use of vaccination in stopping the spread of disease.
 - Evaluate the importance of vaccination to society.
 - If you had children, would you get them vaccinated? Justify your answer.
- Find how the world's usage of antibiotics is related to the emergence of new diseases. Gather information about the following issues:
 - the rate of antibiotic consumption in the world today
 - the rate at which new diseases or new strains of known diseases are being discovered
 - how a high rate of use of antibiotics leads to new, more dangerous strains of disease
 - other factors that could contribute to the emergence of the new pathogens.

Present your information as a brochure for doctors and patients on why they should limit the use of antibiotics. **L**

3 Find out about MRSA (Methicillin Resistant *Staphylococcus aureus*), a type of bacteria that is resistant to penicillin and around 20 other antibiotics, antiseptics and disinfectants. MRSA is becoming more widespread and its rise is thought to be directly related to the widespread use of antibiotics. Find details about:

- the rate of antibiotic consumption in the world today
- MRSA and how it is fought currently
- the rate at which new diseases or new strains of known diseases are being discovered
- how overuse of antibiotics can lead to new, dangerous strains of diseases
- other factors that might contribute to the emergence of new diseases.

Present your work in one of the following ways: 

- as a brochure for patients and doctors encouraging them to limit antibiotic use
- as an email from the Health Department to doctors
- as a TV or radio community announcement.

e-xploring

To research a communicable disease, web destinations can be found on **Science Focus 4 Second Edition Student Lounge**.



Some diseases you might investigate are anthrax, chickenpox, diphtheria, gonorrhoea, syphilis, herpes, hepatitis A, malaria, rubella, shingles, yellow fever, giardia, influenza or the common cold.

a Whatever disease you choose, find out:

- what causes the disease
- how it is contracted
- parts of the world in which it mainly occurs
- how it is spread
- signs and symptoms
- how rare/common it is
- the treatment used (if any).

b Present your information in an electronic format for display (e.g. PowerPoint, Microworlds or a website). 

4.4 PRACTICAL ACTIVITIES

1 Modelling the transmission of disease

Aim

To demonstrate the transmission route of a disease

Equipment

- 1 test tube per person
- phenolphthalein indicator
- 0.1 M sodium hydroxide
- 0.1 M hydrochloric acid
- 1 Pasteur pipette per person

Method

- Each student is given a test tube containing 3 cm³ of liquid.
 - One of you will have 3 cm³ of 0.1 M sodium hydroxide (NaOH) solution. If it happens to be you, then you are 'infected' with NaOH disease, but you won't know it! Only the teacher will know who the infected person is.
 - All other students have 3 cm³ of water.
- You will have 30 seconds to walk around the room, putting five drops of your solution into the tubes of everyone you come into contact with. Note who you make contact with.
- After the 30 seconds, add 3 drops of phenolphthalein indicator to your test tube. All 'infected' people will see a purple colour in their tubes. Note the number of infected people.

- 4 Repeat the activity, but this time allow one minute for everyone to move around the room. This time:
- half of the students will have 3 cm³ of 0.1 M hydrochloric acid in their test tube. This represents an 'immunisation' since the acid will neutralise any 'infection' with NaOH disease
 - one person will still be 'infected' with 3 cm³ of 0.1 M sodium hydroxide solution
 - the rest of the students will have 3 cm³ of water in their tubes
 - the 'infected' and the 'immunised' people will not know who they are until later.

Questions

- 1 Is it possible to work out who was the original infected person? **Justify** your answer.
- 2 **Describe** any difference you observed in the spread of your disease when the time for infection became longer.
- 3 The spread of disease was different when half of the people were immunised. **Describe** how.

2 Effectiveness of antiseptics

Aim

To investigate the ability of various antiseptics to kill disease

Equipment

- 5 Petri dishes containing the nutrient agar
- cotton buds
- masking tape
- 4 different antiseptics e.g. tea-tree oil, eucalyptus oil
- commercial antiseptics
- gloves

Method

- 1 Expose all agar plates to the air.
- 2 Tape one dish shut. This is your control.
- 3 Dip a cotton bud in one of the antiseptics and carefully brush it in an 's' pattern over the surface of one of the agar plates as shown in Figure 4.4.16.
- 4 Repeat step 2 for the other three antiseptics. Use a separate cotton bud to avoid cross-contamination.
- 5 Tape all dishes shut and put them in a warm place for 48 hours.
- 6 After 48 hours, take them out and record your results.



Safety

Do not open the Petri dishes once sealed. Look at them through the plates.

Questions

- 1 Sketch the appearance of the control and the other plates.
- 2 **Describe** the effect that each antiseptic had on the growth of bacteria.
- 3 **Compare** the effectiveness of the four antiseptics.
- 4 Which was the most effective antiseptic? **Justify** your answer.
- 5 **Explain** why cross-contamination would confuse your results and any conclusion reached.

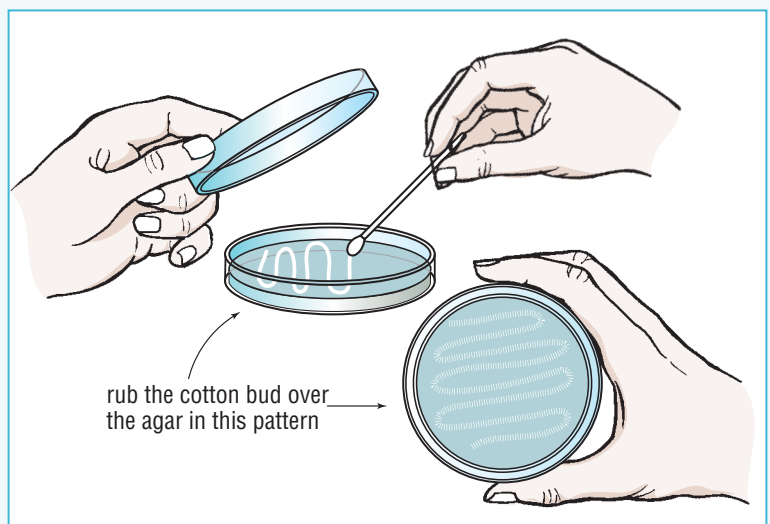

Fig 4.4.16

context

Many diseases are **non-infectious**, meaning that they cannot be 'caught'. They are not transmitted and are not caused by pathogens. The causes of non-infectious conditions are varied and frequently unknown. Some conditions are genetic while others seem to be linked with environmental factors.

Genetic diseases

Genetic diseases are caused by abnormalities in one or more genes or by an abnormal number of chromosomes. This means that the codes contained on the chromosomes for building new cells is faulty.

These genetic abnormalities could be caused by a genetic **mutation** in:

- the patient's family tree, which is then inherited by the patient (inherited genetic condition)
- the patients themselves (non-inherited genetic condition).

Whatever their cause, genetic conditions are not infectious and cannot be 'caught'.

Inherited genetic diseases

Genetic diseases such as **albinism** (a lack of pigment in the skin, hair and eyes), **haemophilia** (the lack of a clotting factor in the blood) and colour blindness are recessive and only occur when parents either suffer from the disease or are healthy but are both carriers of it. Inherited diseases are sometimes sex-linked: although girls can inherit the disease, they are far less likely to have it than boys.

Non-inherited diseases

Sometimes a disease like diabetes shows up suddenly in a family that has no previous history of the disease. This is caused by a new gene mutation in the gametes or sex cells of the parents. The cause of gene mutation is often unknown but **mutagens** such as radiation, drugs, chemicals and some viruses may be responsible. Once a new gene mutation has happened, the disease it causes will be passed into future generations.



Fig 4.5.1 An elderly woman with neurofibromatosis, a rare inherited disorder that causes soft, fibrous non-cancerous tumours. Because it is a genetic disease, it cannot be 'caught'.

Humans are normally born with 23 pairs of chromosomes, one chromosome from each coming from their mother and one from their father. **Down syndrome** (or Tri-21) is a condition whereby a child is born with three formed chromosomes on pair 21 instead of the normal two. This condition is not usually inherited, but some women have an increased risk of having a child affected with it. The chance of a woman having a child with Down syndrome increases with her age: at 25 the risk is 1 in 1250, but by the time a woman is 45 the chance has risen to 1 in 30.

It is possible to test for some genetic disorders while the child is still in the womb.

[Go to](#) [Science Focus 4 Unit 3.3](#)

Diseases caused by diet

Many diseases can be linked directly to what and how much we eat.

Malnutrition

People in developing countries generally do not have the quantity or range of foods that you have. This makes them susceptible to malnutrition. Vitamin and mineral deficiencies can result in sickness or death.

Non-infectious diseases

In Australia most people have access to sufficient food. Despite this, many have poor diets, eating too much of one type of food and they therefore have deficiencies in essential nutrients, fibre, vitamins and minerals.



Fig 4.5.2 Humans have 23 pairs of chromosomes. Sometimes three chromosomes occur instead of the usual two on pair number 21. When this happens, Down syndrome (Tri-21) occurs. Tri-21 is a non-inherited genetic disease.



Fig 4.5.3 This refugee child is getting adequate carbohydrates, but is at risk of kwashiorkor, caused by protein deficiency.

Obesity

Obesity is a widespread problem in Australia and much of the Western world. Excessive weight places a strain on all body systems, causing high blood pressure, joint and blood vessel problems and an increased chance of developing diabetes. Flexibility is also reduced, making it difficult to perform simple tasks such as tying shoelaces.

Eating disorders

Anorexia nervosa results in severe weight loss, often enough to cause massive organ failure and death.

Bulimia nervosa is a related disorder but is characterised by a 'binge and purge' cycle: whereas those with anorexia tend to eat little, bulimics tend to eat well. They then deliberately vomit whatever has been consumed, causing an imbalance of **electrolytes** (mineral salts). Electrolytes are substances that conduct small electric currents through the nerves to your muscles. They are responsible for maintaining a regular heartbeat and a loss of them can result in heart failure.

Diabetes

Diabetes mellitus is a disease in which glucose, the energy source for your body, is not used correctly due to lack of a hormone called **insulin**. Diabetes seems to have some genetic component but there is no defined pattern of inheritance. There are two types:

- juvenile onset (Type I)
- mature onset (Type II). Being overweight is a common factor in Type II cases.

If the insulin deficiency is serious, regular monitoring and injections are needed throughout the patient's life. If the condition is less serious, it can often be controlled through tablets or diet. An uncorrected lack of insulin can result in a diabetic coma and death.

Science Clip

Monkey magic

Recent research may soon end the daily insulin injections needed by millions of diabetics. After receiving a transplant of insulin-secreting cells, diabetic monkeys did not require injections of insulin. They did, however, need to keep taking a drug that stopped the body's natural rejection of the transplanted cells.

Diseases of the circulatory system

In Australia, heart disease is the leading cause of death in males over 35 and females over 60. The term covers conditions that affect the blood vessels of the circulatory system and not just the heart. These conditions are generally caused by poor diet, smoking and a lack of regular exercise.



Fig 4.5.4 Regular exercise is a key to avoiding diseases of the circulatory system.

Thrombosis and embolism

Thrombosis is a disease that causes a large, solid mass (a **thrombus**) to form on the inside wall of a blood vessel. Sometimes these large masses detach and end up blocking major arteries, causing death. The blockage of a blood vessel is called an **embolism**. The embolism can result from a thrombus, a bubble of gas, fat, tumour cells or some type of foreign body.

Stroke

A **stroke** occurs if the blood supply to part of the brain is cut off by either a blockage (embolism) or a burst blood vessel (**haemorrhage**). Brain cells immediately start to die. One third of stroke victims die soon after, another third eventually fully recover. The other third need intensive care since they are often paralysed, particularly down the left side of the body. Forty-eight thousand Australians suffer stroke every year: this amounts to one stroke happening every 11 minutes! Stroke is the biggest cause of disability in Australia and the third biggest killer. Health costs associated with it amount to \$1.3 billion per year.

Although little can be done for a haemorrhage stroke victim, new techniques are regularly being used in emergency operating rooms to remove blockages in the brain. An injection of special chemicals soon after the attack will sometimes dissolve embolisms in the brain. Another approach is to use a microscopic ‘corkscrew’ that is inserted into the blood vessel. It burrows into the embolism so that bits of it can be pulled away, eventually clearing the blockage.

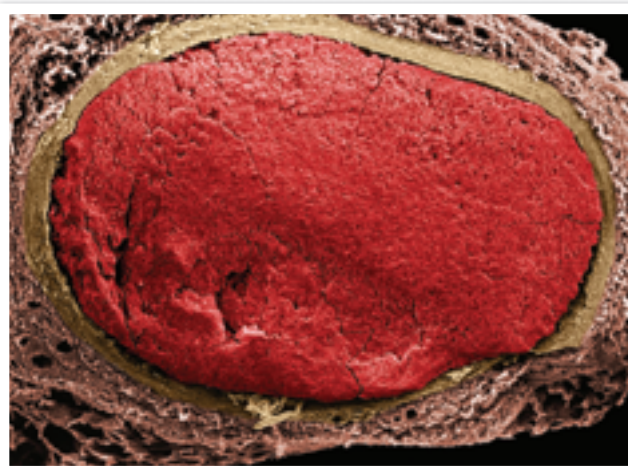

Fig 4.5.5 A thrombus can block a blood vessel completely or break away, travel to the brain and cause a stroke. This thrombus is completely blocking a coronary artery.

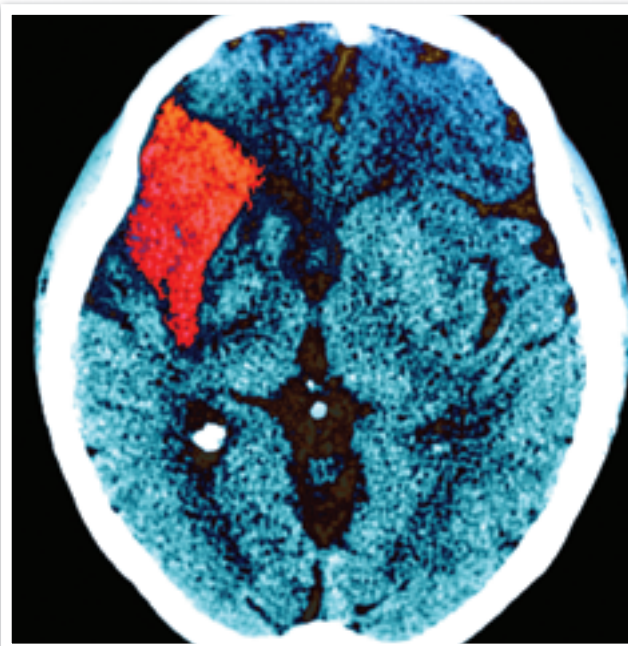

Fig 4.5.6 A CT scan of the top of the brain of a stroke victim—the part of the brain coloured red has died because blood could not get there due to a blockage of arteries feeding that part of the brain.

Science Fact File

Economy class syndrome

Passengers on long flights do not get much chance to move about, and this inactivity sometimes causes a thrombus to form in blood vessels in the legs or feet. This **deep vein thrombosis (DVT)** is not a major problem, but quickly becomes so when the passenger gets moving again. The thrombus will often start moving, only to block more vital blood vessels in other parts of the body, maybe in the lungs, heart or brain. Death often results, perhaps in the terminal after departing the plane. All age groups can suffer from DVT and airlines now recommend that on long flights you exercise your legs and feet to keep blood flow moving in them. You will find these exercises in the in-flight magazines and sometimes on one of the video channels.

Varicose veins

Irregularities in vein walls and weaknesses in the valves can stop blood flowing back to the heart normally. Varicose veins are the result and are usually seen in the legs, where blood must fight gravity to get back to the heart. Unsightly, bulging veins develop wherever blood is trapped.

They are more likely to occur in women than in men, and are usually inherited. If you are female and one of your parents has varicose veins, then there is a very good chance that you will develop this condition.



Fig 4.5.7 Varicose veins are caused by a fault in the valves.

Coronary heart disease

Coronary heart disease is usually caused by arteriosclerosis but refers to anything that reduces blood flow to the heart. It can cause milder attacks of chest pain, called **angina**, or a serious heart failure, called a heart attack. About 25 per cent of people with coronary heart disease die suddenly from a heart attack. Some diseases (such as diabetes) can also weaken the heart muscle.

Cancer

Cancer occurs when the division process that produces new cells occurs uncontrollably. Cells are dividing all the time via a carefully controlled process. Tiny changes within cells can be enough to disturb the process and produce cancer. Cancer can occur anywhere in the body. The most common sites for cancer are the skin and prostate in men and the breasts in women.

A **tumour** is any abnormal growth in the body and can be one of two types:

- a **benign** growth in which the cells are not rapidly dividing—a wart is an example of a benign tumour
- a **malignant** growth—its cells are undergoing uncontrollable growth.

A **biopsy** is carried out to determine whether a tumour is malignant or benign. In this process, a small sample of tissue is taken which is then analysed under a microscope.

Science Clip

Flossy hearts

Want to know one easy way to help keep your heart healthy? Floss your teeth! Gum disease can result in your mouth having an extremely high concentration of bacteria. These bacteria can end up in your bloodstream and cause damage to your heart.

Science Clip

Magic margarine

Cholesterol is a vital component of all your cells, but too much of it in a diet can lead to arteriosclerosis. There are now margarines available that contain plant sterols, substances which can actually lower the amount of blood cholesterol. This is good news for all those heart patients condemned to low-fat diets—for the first time, margarine may actually make them healthier!

High blood pressure

Hypertension is the name given to persistent high blood pressure. It can cause **arteriosclerosis** (hardening of the arteries) and coronary heart disease. The worst type of arteriosclerosis is called atherosclerosis. It is characterised by fatty deposits within arteries. These deposits can eventually cause arteries to become blocked. Atherosclerosis can occur in any part of the body, not just the heart. It can be inherited, but is also strongly linked to environmental factors like smoking and diet. Although more common in women, it produces much more serious effects in men.

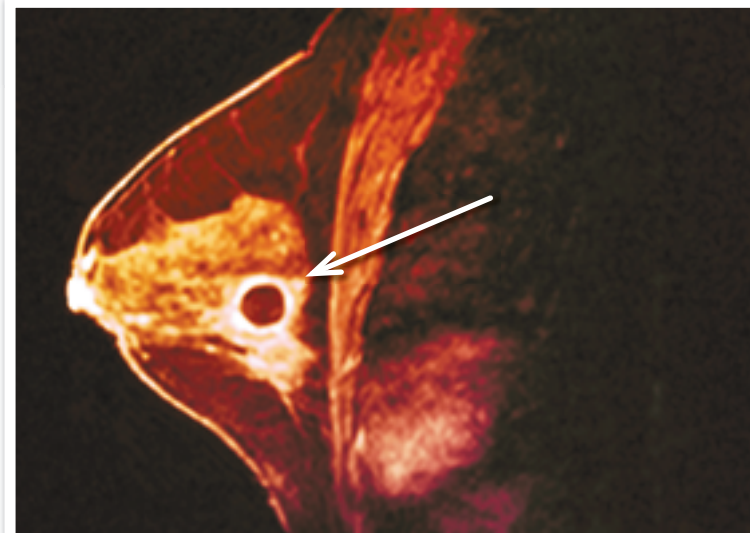

Fig 4.5.8 A coloured MRI scan showing a malignant breast cancer (red) at right. Note the increased blood supply to the tumour.

The development of cancer

Factors that make someone more susceptible to cancer are:

- environmental—smoking of any type (lung cancer), exposure to UV radiation from the sun or tanning beds (skin cancer), poor diet (bowel cancer), and exposure to cancer-causing chemicals known as **carcinogens**—(benzene is a known carcinogen)
- genetic predisposition—some families have histories of breast or prostate cancers suggesting that those cancers have some inherited characteristics.

Cancer treatment

If a malignant growth is found, it needs to be treated before **metastasis** occurs. Metastasis is when cancerous cells find their way into the circulatory or lymph systems and travel to other parts of the body. The disease becomes very difficult to treat once secondary cancer sites called **metastases** develop.

Melanoma, for example, is a form of deadly skin cancer that occurs more often in Australia than any other country: roughly 10 000 people are diagnosed with melanoma each year and more than 1300 die (another 400 000 people are diagnosed with less aggressive but still potentially deadly skin cancers each year). Melanoma is now the second most common cancer in men and women in NSW. Melanomas only need to grow to a depth of one millimetre before they become deadly! At that depth, cancerous cells can move through the bloodstream to the lymph nodes and eventually metastasise into cancers elsewhere in the

Fig 4.5.9 All melanomas require surgery. A melanoma less than one millimetre deep will require flesh to be removed one centimetre on either side of the melanoma and up to 8 centimetres long. This causes severe scarring. If ignored, melanomas will spread, metastasise and kill. Sunbathing dramatically increases your chance of getting a melanoma. The line drawn around the melanoma here indicates how much flesh needs to be cut away.

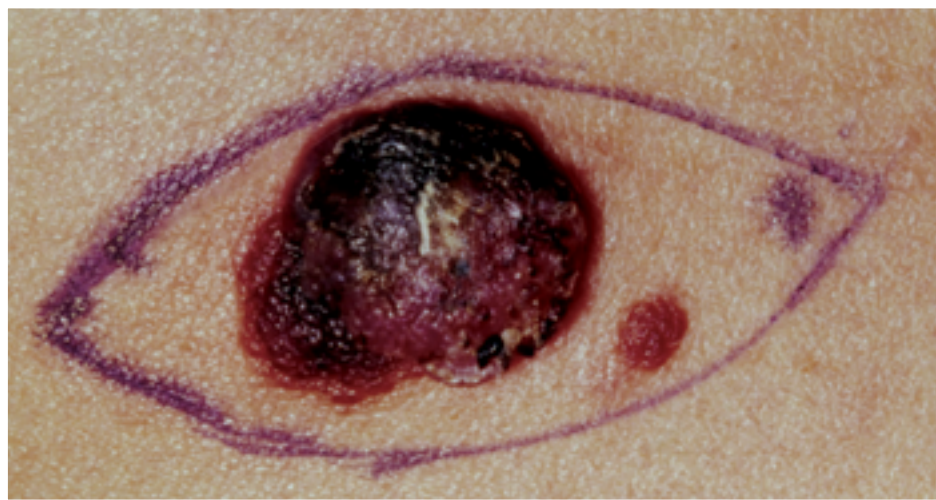

body. Like all cancers, melanomas are treated in three different ways depending on their size and all treatments have serious side-effects:

- surgery—some healthy cells surrounding the tumour need to be removed, often resulting in serious scarring
- radiotherapy—this treatment uses radiation to kill localised growths. Although targeted at the cancer cells, other healthy cells are usually affected too and this can cause illness, fatigue and often a loss of hair
- chemotherapy—this treatment uses chemicals to poison cancerous cells. It too affects healthy cells and can cause similar side-effects to radiotherapy.

The best chance for surviving cancer is to detect it early while it is still small, before metastasis. Never ignore unexplained lumps anywhere on your body or changes in the colouring on your skin. Moles are prime sites for melanomas and should be regularly checked for changes.

Go to [Science Focus 4 Units 1.3, 3.3, 8.3](#)

Illegal drugs

Any substance that has the ability to alter a person's body chemistry is termed a **drug**. They include legal drugs such as aspirin, alcohol, nicotine and insulin and illegal drugs such as cannabis, heroin and speed.

Psychoactive drugs are those that alter mood. Some are legal (such as medically prescribed tranquilisers for depression and ADHD). Most, however, are illegal because of their addictiveness and the short- and long-term harm they can do. Ecstasy, for example, quickly raises body temperature and can lead to dehydration, while some users of marijuana develop sustained memory loss and longer term mental disorders. The table on page 160 outlines the short- and long-term effects of illegal drugs.

Science Clip

Illegal drugs were once used for medicine!

Heroin was first developed in 1898 by the German drug company Bayer as a sedative that was supposed to make you feel like a hero (hence its name). Cocaine was first developed in 1860 as an anaesthetic. Amphetamines were first developed in 1932 by the US drug company Smith, Kline and French to relieve clogged noses.

Non-infectious diseases

Drug	Common names	Short-term effects	Long-term effects	Danger
Cannabis	Marijuana, grass, pot, dope, Mary Jane, hooch, weed, hash, joints, brew, reefers, cones, smoke, mull, buddha, ganga, hydro, yarndi, heads, green	Euphoria, poor coordination, affects sense of time, increased appetite, thirst, dizziness, loss of coordination, paranoia	Respiratory problems, depression, memory problems, decreased motivation, reduced levels of sex hormones, dependence	May unlock existing illnesses such as schizophrenia in those susceptible
Amphetamines	Speed, uppers, buzz, crystal, meth, crystal meth, base, pure, ice, shabu ox blood	More energy, hyperactivity, less appetite, dry mouth, higher blood pressure and heart rate, nausea	Sleep problems, extreme mood swings, compulsive repetition of actions, paranoia, depression, anxiety, panic attacks, seizures, dependence	Psychosis with hallucinations, paranoid delusions, uncontrolled violent behaviour
Speed (derived from amphetamines)	Uppers, buzz	Stimulant, increases heart rate, decreases fatigue, feelings of agitation, excited speech	Can lead to brain damage, memory loss, psychotic behaviour and heart problems	As above
Crystal meth (derived from amphetamines)	Crystal, ice	As above	As above	As above
Ecstasy (derived from amphetamines)	E, eccy, XTC, pills, eggs, doves, MDMA	Feeling of closeness to others, lack of inhibitions, chewing, teeth grinding, nausea, inability to sleep increases body temperature that can lead to death	Damages brain and memory, depression, cracked teeth	Severe reactions, death
Ketamine	Green, K, super K, special K	Delirium, amnesia, affects movement, speech and vision, increased body temperature, can cause fatal breathing difficulties	Damages attention span, memory, personality and mood changes	Depression, amnesia
LSD	Acid, trips, holidays, blotters, microdots, tabs, tickets. Street name often depends on the design of the blotting paper squares	Hallucinogen, increased heart rate, higher body temperature, tremors, paranoia, effects often unpredictable	Panic attacks and persistent psychosis and 'flashbacks', recurring hallucinations	Paranoia
GHB	Fantasy, liquid ecstasy, liquid E	Drowsiness, induced sleep, nausea, reduced inhibitions, dizziness, headache	Agitation, extreme drowsiness, hallucinations, difficulty focusing eyes, vomiting, stiffening muscles, disorientation	Convulsions, short-term coma, respiratory collapse, amnesia, impaired movement and speech

Alcohol and smoking

Alcohol and nicotine are the most widely used (and abused) drugs, largely because they are legal, widespread, socially acceptable and can relieve stress when taken in limited quantities. They can, however, cause diseases and medical conditions just as devastating as illegal drugs—both to the user and to those around them.

Alcohol

In Australia, approximately seven per cent of all male deaths and four per cent of all female deaths can be directly attributed to alcohol.

Alcohol is technically a **depressant** drug. While it doesn't necessarily make you depressed, it does depress your central nervous system, slowing down its responses. Alcohol has different effects depending on how much is consumed:

- alcohol initially gives a sense of warmth and wellbeing, and a loss of inhibitions
- with a little more alcohol, muscle coordination becomes difficult and speech slurred. Reactions are slower and the senses become dulled. Alcohol is a cause of around one-third of all road deaths.

Therefore the legal blood alcohol content (BAC) in New South Wales is zero for all learner and provisional licence holders. The legal BAC for all other drivers is 0.05 per cent.

If more alcohol is ingested then intoxication occurs. The person will be staggering, nauseated, possibly vomiting, and will have difficulty speaking. People are likely to fall into a coma if their blood alcohol content gets to 0.40 per cent. Death through heart and respiratory failure can occur at around 0.60 per cent. This rarely happens, however, since unconsciousness and vomiting have usually forced the person to stop drinking.

Alcohol also stimulates urine production, dehydrating body cells. Part of the liver is put out of action while it works on processing alcohol. By-products of all this processing are poisonous chemicals that are then released back into the blood. It is a combination of dehydration and these chemicals that give the symptoms of a hangover.

Binge drinking is particularly harmful since it gives no time for the body to process the alcohol.

Chronic alcohol abuse causes many ill-effects including:

- digestive problems—alcohol destroys the lining of the stomach

- malnutrition and vitamin deficiencies—diet is often neglected. Although alcohol is rich in kilojoules, it has no nutrients
- long-term damage of the liver—alcohol can cause cirrhosis, a disease where cells are replaced by fibrous tissue
- heart damage—alcohol can harden artery walls
- destruction of brain cells
- slow deterioration of the central nervous system.

The abuse of alcohol can result in the disease called **alcoholism**, where drinking is compulsive and the person dependent on it. This dependence is most often psychological, but can develop into a physical dependence.

Science Clip

Sexist alcohol!

Alcohol affects different people very differently. Its effects will depend on your body weight, fat content, age, mood, previous exposure to alcohol and many other factors. Women have a higher fat content than men and so are not able to metabolise as much alcohol as men. Women will therefore be affected by smaller amounts. In both sexes, even small amounts of alcohol can make the symptoms of mood disorders like depression and anxiety much worse.



Fig 4.5.10 Binge drinking is known to cause major short- and long-term medical conditions.



Worksheet 4.5 Blood alcohol concentration



Fig 4.5.11 If you smoke, then you are more susceptible to lung cancer, throat cancer and cancer of the voicebox.

Smoking

The harmful effects of smoking have long been well documented. Despite this, every year young people take up the habit. More young women than men are currently smokers, one possible reason being that it is an appetite suppressant. The nicotine in tobacco is addictive and once the habit is formed, it is not an easy one to give up. Withdrawal symptoms include intense craving, anxiety, sweating, depression, sleep problems and difficulty concentrating. It often takes many attempts before people are able to kick the habit for good.

Before you think about lighting up, think about these statistics. Smokers are likely to have:

- more accidents than non-smokers due to the slowing down of their reflex actions following a cigarette
- constriction of blood vessels which means that smokers' brains don't work as well as non-smokers' brains
- a middle-age death rate twice that of non-smokers
- an increased risk of developing many diseases, not just lung cancer
- an increased risk of having low birthweight babies with health problems and reduced intelligence if the mother smokes during pregnancy
- bad breath
- stained teeth and fingers.

Environmental hazards

Exposure to radiation, heavy metals such as lead, and chemicals such as dioxins or materials such as asbestos are all environmental hazards that can cause disease. Although usually avoidable, some people are exposed to them without warning. Many environmental diseases have only been diagnosed relatively recently, since many take a long time to develop. Asbestos, for example, was thought to be safe by the builders and home renovators that used it and the workers that mined it and produced it. Many have, however, developed an aggressive lung cancer called mesothelioma. Although now banned, much asbestos is still in place in buildings, in the clutches of old cars and even in the ships of the Royal Australian Navy. People continue to be exposed to it.

Radiation

Radiation can come from natural sources like the Sun, or can be generated from artificial sources like X-rays, mobile phones, overhead power lines and nuclear explosions. Some types of radiations are known to cause mutations in genetic material in the cells, producing various cancers.

Heavy metals

The heavy metals include mercury, thallium, lead and bismuth. The human body has no method of ridding itself of these metals and they build up with each exposure to them. For this reason they are often called **cumulative poisons**. Throughout history, mercury and lead were used for many purposes before their ill-effects were known, poisoning people as they were used.

Lead poisoning has been linked to the exhaust from cars and from flaking old-fashioned lead-based paint.



Fig 4.5.12 Flaking from old lead-based paints has been linked to lead poisoning in humans.

Lead is rarely used in paint these days, but renovators of old homes are exposed to it when sanding and ripping down walls. Chronic lead poisoning has many ill-effects, including foetal deformities in pregnant women and mental impairment in children.

Go to  Science Focus 4 Unit 8.4

Mental illness

It is estimated that one in five Australians suffers from a mental health problem severe enough to affect their ability to lead a normal lifestyle. Mental illnesses are not, however, discussed with the same openness as many other illnesses: not only do sufferers have to deal with the disease, but they must also deal with the stigma that society places on those with mental disorders. Mental illnesses include:

- anxiety disorders such as panic attacks
- phobias—an irrational fear of a specific object (e.g. spiders), place (e.g. the beach), or situations (e.g. flying or, as with agoraphobia, the fear of being away from home, or in open or crowded spaces)
- obsessive-compulsive disorder—being driven to act in a certain way by an irrational fear (e.g. compulsively washing of hands because of a fear of germs)
- Attention-Deficit/Hyperactivity Disorder (ADHD)—inattention, hyperactivity and being overly impulsive
- depression (also called depressive illness)—an overwhelming sadness and grief that is not able to be relieved
- bipolar disorder—characterised by extreme mood swings between depression and manic and frantic behaviour, loss of inhibitions, grand plans and overt and extreme happiness

- schizophrenia—characterised by hallucinations, delusions, and inappropriate behaviour and actions. Schizophrenia can be triggered in susceptible people by extreme tension and conflict and by use of drugs such as marijuana. Some families are more susceptible to the condition, suggesting a possible genetic link.

Society's attitude towards those with mental illness can result in them feeling even more isolated, rejected and shamed. Mental illnesses are, however, no different to other types of illness and there are symptoms and treatments. They can be inherited or caused by other factors such as drug abuse. Anyone that is ill needs acceptance, understanding and respect from those around them. People with mental illnesses need that too, more than anything else.



Fig 4.5.13 Depression is a common mental illness that can be overcome with support and counselling.



4.5 QUESTIONS

Remembering

- 1 State** whether the following statements are true or false.
 - a Gene abnormalities are always inherited.
 - b Older women have less chance than younger women of having a child with Down syndrome.
 - c Vitamin and mineral deficiencies can cause death.
 - d An imbalance of electrolytes is not a serious health problem.
 - e Heart disease is the leading cause of death in Australian men over 35.

2 Name:

- a four mental health problems
- b three diseases associated with diet
- c two inherited diseases
- d one non-inherited disease

3 List:

- a four factors that can lead to cancer
- b three negative effects of drinking alcohol
- c two environmental factors that can lead to disease

- 4 Choose** one psychoactive drug and **list** the likely side-effects.

- 5 Specify** the depth at which a melanoma starts to spread through the body.

Understanding

- 6** Genetic diseases cannot be caught. **Explain** why.
- 7 Explain** how a child with a genetic condition can be born to parents who show no outward signs of the condition.
- 8 Explain** why people who eat lots of hamburgers and fries can still be malnourished.
- 9 Define** the following terms:
- thrombosis
 - embolism
 - hypertension
 - arteriosclerosis
- 10** Diabetes is a disease connected with diet. **Describe** how diabetes affects the body.
- 11 Describe** three things you can do to keep your heart healthy.
- 12 Explain** what can happen if an embolism forms in:
- the brain
 - the legs of a plane passenger on a long flight
- 13** Strokes are now much more survivable. **Explain** how.
- 14** Cancer can be treated in a variety of ways. **Describe** three of these.
- 15 Explain** why metastases make it difficult to treat cancer.
- 16 Explain** why alcohol is considered a depressant.
- 17 Describe** the effects of blood alcohol levels above 0.60 per cent.
- 18** It is well known that long-term alcohol consumption damages one's health. **Describe** some of the effects of long-term alcohol abuse.

Analysing

- 19 Contrast:**
- anorexia nervosa and bulimia nervosa
 - a benign tumour and a malignant tumour
 - bipolar disorder and schizophrenia
- 20 Analyse** what is happening in Figure 4.5.14 and list the non-infectious diseases he is at risk of getting.



Fig 4.5.14

- 21 Discuss** the law that prohibits P-plate drivers from drinking alcohol and driving.
- 22** A healthy woman is three months' pregnant and has just discovered that her child has a genetic disorder. Should she have it anyway or should she abort it? **Discuss** the issues for and against.

Evaluating

- 23 Propose** reasons why young people are tempted to use illegal drugs like marijuana.
- 24** Mental illness is a common problem. **Propose** reasons why it is not discussed openly like most other diseases.
- 25** Decide whether caffeine is a drug. **Justify** your answer.

Creating

- 26** Figure 4.5.15 shows a normal vein. **Construct** a diagram showing what you think a varicose vein might look like.

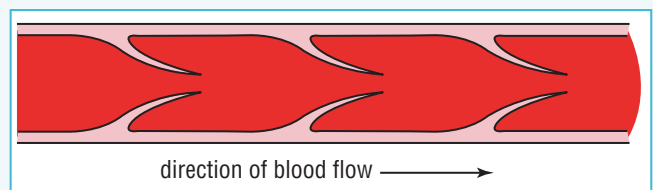



Fig 4.5.15

4.5 INVESTIGATING

Investigate your available resources (for example, textbooks, encyclopaedias, internet) to complete the following tasks.

- 1 Find details about a genetic condition such as thalassaemia, sickle cell anaemia, cystic fibrosis, colour blindness, haemophilia, or albinism. Whatever condition you choose, you must find:
 - how common it is
 - whether it is sex-linked and why
 - what its effects are
 - any treatment or care necessary
 - if the life span of people with the condition is reduced.

Present your findings as a speech, video or PowerPoint presentation to inform a group of parents who have just been told their child has a genetic condition. 

- 2 Research one type of heart disease such as angina, heart attack or stroke and/or one mental illness. For the conditions you research, find:
 - how many people it affects annually in NSW and the rest of Australia
 - factors that increase the risk of getting that condition
 - what age groups it mostly affects
 - its symptoms
 - the treatment or medical care afterwards
 - life after treatment.

Present your work as a poster. 

- 3 Find what exercises are recommended by airlines to minimise the possibility of getting DVT. Present your findings in one of the following ways:
 - a demonstration for use by flight attendants
 - a short article for the in-flight magazine 
 - a video to show passengers early in the flight.

Reviewing: *Supersize Me*

Supersize Me (2004) is a film in which Morgan Spurlock eats nothing but McDonald's. Watch *Supersize Me* and prepare a film review about it. In your review you must:

- state its length, the lead actor, director, producer, studio and year of production
- state how long Spurlock stayed on his diet
- describe his changing health
- compare his diet for the month with that recommended by the CSIRO
- list what nutrients Spurlock's diet had too much of and what it lacked
- assess whether it is realistic for a Year 10 student or anyone else to consume only McDonald's
- assess how often you go to McDonald's or have take-away food
- assess how fair the film is to McDonald's.

Present your review in one of the following ways: 

- an interview with Spurlock, Ronald McDonald or with a leading nutritionist
- a segment for a TV program such as 'ET', 'At the Movies' or 'The Movie Show'
- a single page spread for an entertainment magazine or for a movie guide.

e-xploring

To explore drugs and alcohol use/abuse, a list of web destinations can be found on **Science Focus 4 Second Edition Student Lounge**.



- 1 Produce a list of reviewed websites that could be recommended to someone who needs support to quit their habit.
- 2 Present your reviewed sites as a web page for people looking for help in this area.

CHAPTER REVIEW

Remembering

- 1 **Specify** an example of a disease and its symptoms.
- 2 **List** three types of nutrients.
- 3 **State** an example of a psychosomatic illness.
- 4 **List** the types of micro-organisms that cause disease.
- 5 **List** the types of things vaccines can be made of.
- 6 **List** three heavy metals that can cause health problems.

Understanding

- 7 **Explain** why pathologists carry out autopsies.
- 8 **Clarify** what is meant by *virulence*.
- 9 **Use** an example to clarify what is meant by the term *pathogen*.
- 10 **Describe** ways in which natural control of disease occurs in our bodies.
- 11 **Describe** ways in which artificial control of disease is achieved.
 - a **Outline** the role of chromosomes.
 - b **Describe** what a mutation is.
 - c **List** factors that may cause a mutation to occur.
- 12 **Outline** the results of metastasis.
- 13 Recreational drugs often have long-term effects on health. **Describe** the effects caused by marijuana.
- 14 **Outline** the effects of lead poisoning.
- 15 **Describe** how the spread of a disease can be prevented if it is:
 - a water-borne
 - b air-borne
- 16 Some very old bacteria have been found still alive, trapped in ice in polar regions. **Explain** how they have survived for so long.
- 17 **Explain** why fungi are called opportunistic pathogens.
- 18 **Explain** how immunity is achieved as a result of vaccinations.

Applying

- 19 **Identify** the correct words to complete these sentences.
The study of disease is called _____. A plant or an animal is an _____. A very small _____ is called a _____. An _____ causes disease. Parasites use a _____ for food and _____. _____ is a measure of how much a disease damages the host. Another name for an epidemic is an _____.
- 20 Many diseases have common symptoms. **Identify** one symptom that all diseases have in common.

- 21 Use the table on page 136 to **identify** the name of the pathogen that causes:
 - a cholera
 - b thrush
 - c food poisoning

Analysing

- 22 **Analyse** what is happening in Figure 4.6.1. **Specify** what is acting as:
 - a the host
 - b the vector

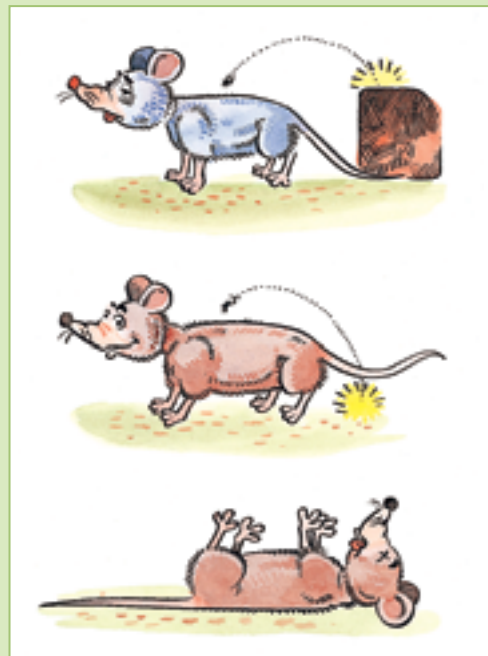

Fig 4.6.1

- 23 Use Figure 4.1.2 on page 123 to **assess** whether the people shown have good health.

Evaluating

- 24 **Distinguish** between benign and malignant tumours.

Creating

- 25 **Construct** diagrams showing the shape of bacteria that cause:
 - a syphilis
 - b sarcina
 - c gonorrhoea

Worksheet 4.6 Crossword

Worksheet 4.7 Sci-words



Evolution

5

Prescribed focus area

The history of science

Key outcomes

5.1, 5.8.3

- There is evidence that present-day organisms have evolved from organisms in the distant past.
- Organisms have adaptations that enable them to survive and reproduce in their environment.
- Adaptations can be structural, functional or behavioural and are passed on from one generation to the next.
- Different mechanisms for evolution have been proposed, modified, rejected and confirmed as new evidence has been found.
- Natural selection is the mechanism that best explains the process of evolution and the available evidence.
- Depending on their religion and cultural background, different people have different views on how life originated on Earth.

Unit 5.1

Being suited to your environment

context

Nearly two million different kinds of plants, animals and microbes are known to be currently living on Earth. More are being found each year. Many more organisms have come and gone, as the average time that a species survives on Earth is only about four million years. Some, like the dinosaurs, are long

extinct. The extinction of many others is far more recent and a direct result of human activity. Scientists have always wondered how this tremendous diversity of life came to be. Most now agree that all forms of life stem from the same remote beginnings and that the different species we now know have developed gradually over millions of years.



Fig 5.1.1 This moray eel has adaptations that perfectly suit it to the environment provided by the coral reef.

Science Clip

Cuddles the furry shark

New species are usually found in wild and unexplored places, but in 2004, a radically new species of shark was found in a fish tank! Cuddles is a 70-centimetre female shark that is covered in red bristles and has an extra gill. She doesn't swim, but instead hops along the floor of the tank by 'clapping' together her shorter than normal and more muscular fins. Cuddles now lives in an aquarium in Germany but previously lived in a zoo and in an animal rescue centre. Cuddles is originally thought to have come from southern Africa, where it's suspected she lived in dark ocean caves. Her bristles are thought to be an adaptation that give her increased sensitivity to water movement that might suggest food or prey. Cuddles will not get a mate, however, until scientists find out exactly where she came from. It is very likely that this newly discovered species of shark will 'disappear' when Cuddles eventually dies.

Adaptations



Living things or organisms are able to survive and breed because they have certain characteristics that make them ideally suited to their environments. These characteristics are known as **adaptations** and are inherited, being passed from parents to offspring.

Some fish, for example, contain an 'anti-freeze' chemical in their blood that stops them from freezing while swimming in the cold waters of the Arctic. Male lions have long manes, stand as tall as possible and puff out their chest to make them appear larger and more intimidating to opponents.

Plants have adaptations too. The silver-coloured, narrow-shaped leaves of the wattle tree help reduce water loss by evaporation. Some flowers achieve pollination by imitating the shape, colour and smell of a female insect. When male insects attempt to mate with the flowers, they transfer pollen.



Fig 5.1.2 To a male wasp, this orchid looks and smells like a female wasp. This adaptation assists in transferring pollen from flower to flower.

Adaptations can generally be classified as **structural** (where the adaptation is physical), **functional** (where the adaptation involves the internal function of the organism) or **behavioural** (where the adaptation involves the way the animal acts).

Structural adaptations

These adaptations, also known as **physical adaptations**, can take many forms.

- Many animals are camouflaged to blend with their background so that they cannot be seen by predators.
- Some animals are so colourful that they should be easy prey. However, these animals usually sting, taste bad or are poisonous and their bright appearance warns predators to stay away.
- Some animals have features that make them look larger and more frightening to predators. Lizards, for example, sometimes have neck frills that can open which makes the head seem like that of a much larger lizard.

Functional adaptations

These adaptations affect how the internal functions of an animal work. Their internal function changes, depending on their immediate environment. The Arctic fox, for example, grows a dark coat in winter and a white one in summer.



Fig 5.1.4 Both ends of a shingleback lizard look similar, making it difficult for a predator to tell which end is which. The predator might attack the wrong end, giving the lizard a chance to escape.



Fig 5.1.5 Some animals mimic the colourings of a more dangerous animal. The large fake eyes on the wings of this moth make it appear more threatening to a bird.



Fig 5.1.3 A stick insect looks like the twigs and leaves that it lives on, making it difficult for birds to find them. Many animals resemble objects from their environment. Some even resemble bird droppings!



Fig 5.1.6 Chameleons change their colour to blend with changing backgrounds. This is an example of a functional adaptation.

Behavioural adaptations

Behavioural adaptations involve the way an animal acts and can take many forms.

- Some animals sit very still or move slowly to avoid predators.
- Others are active only at certain times of the day or year to avoid extremes of heat or cold.
- Some collect and store food for future use.
- Some predators form packs to hunt food more effectively.



Fig 5.1.7 Many animals form herds or groups to provide extra protection from predators or from the cold.

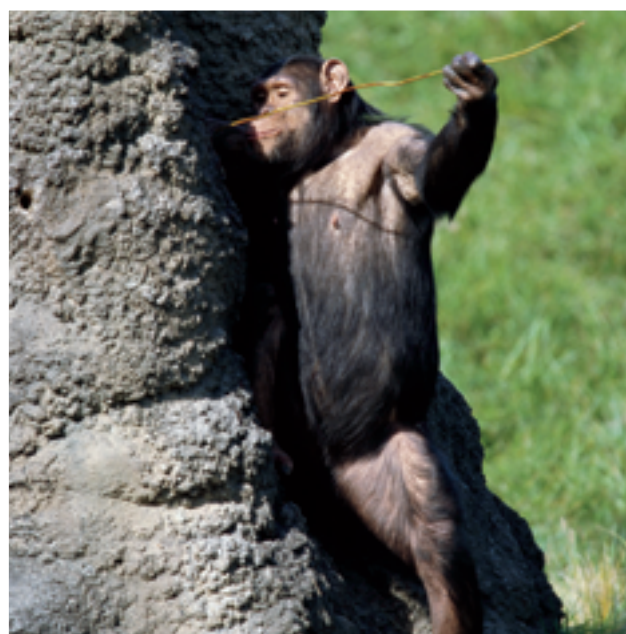

Fig 5.1.8 A few animals have learnt to use tools to access food that is hard to get. Chimpanzees commonly use broken twigs to extract termites. Chimps could also collect them by crushing the nest, but this would destroy an ongoing food source.

Variation

The individuals within a species are very similar, having similar adaptations. All Sumatran tigers, for example, are similar, as are chimpanzees. They are not identical, however, since **variation** occurs within all species. Much of this variation comes from the differences in genes and chromosomes that each individual inherits from their parents. Variation can also result from genetic mutations and from environmental factors such as differences in diet, availability of water and habitat. Although all humans share certain basic characteristics (intelligence, the ability to walk on two feet, hands that can grip) we also vary greatly in colour, hair, eye shape, size and body shape.

Go to [Science Focus 4 Unit 3.2](#)

Favourable characteristics

Every organism has characteristics that are either inherited or acquired.

- **Inherited characteristics** are those features that have come from the parents of the organism. Eye and hair colour in humans are inherited characteristics, while polar bears inherit the characteristics of thick, white fur, an underlying thick layer of fat and a body shape that allows them to survive on the ice sheets of the Arctic.
- **Acquired characteristics** are not inherited, but are developed over the life of an organism. Accidents and surgery mean that humans often acquire characteristics such as scars. Working out at the gym gives people the acquired characteristic of a muscular body. The ability to confidently speak in public is another acquired characteristic.

The survival of a species relies on at least some individuals producing offspring. The organisms best suited to their environment have characteristics that enhance their ability to survive and reproduce. Acquired characteristics only give an advantage to a single generation while favourable inherited characteristics will be passed on to future generations. Over several generations, individuals with favourable characteristics will become the most common.

In contrast, those with less favourable characteristics will find the environment inhospitable. They will be more likely to die before they get a chance to reproduce. It can be said that favourable characteristics are selected.

Variation in a species is particularly important if environmental conditions change. While some die, some individuals will have characteristics that are favourable, allowing them and the species to survive the change.

5.1 QUESTIONS

Remembering

- 1 State** whether adaptations are developed during the life of an animal or are inherited.
- 2 List** three basic types of adaptations with an example of each.
- 3 State** two reasons why individuals within a species are not identical to one another.

Understanding

- 4 Describe** three examples each of an adaptation that is:
 - a structural
 - b behavioural
- 5 Describe** three:
 - a inherited characteristics in a polar bear
 - b acquired characteristics in a human

Applying

- 6 Identify** three similarities and three differences that exist between different members of your own family.
- 7 Identify** whether the red bristles on Cuddles the shark are an adaptation to its tank environment or its original environment of dark ocean caves.

Analysing

- 8 Analyse** the adaptations in the table opposite and match them with their likely survival values and the habitats in which they are likely to occur.
- 9 Classify** the following as inherited or acquired characteristics:
 - a a suntan
 - b black hair
 - c high resistance to a bacterial infection
 - d blue eyes
 - e the athletic ability of a gymnast

Evaluating

- 10 Propose** what the survival advantage is of animals:

- a being able to intimidate
- b being camouflaged
- c forming packs
- d hibernating through a harsh winter

- 11** When African wildebeest cross a crocodile-infested river, they do it as a herd and not as individuals. **Propose** reasons why.
- 12** Like the males of many bird species, male peacocks are very colourful and carry out spectacular displays with their tail feathers.
 - a **Classify** each adaptation as structural, functional or behavioural.
 - b **Propose** how these adaptations allow the species to survive.
- 13** Jackrabbits, bilbies and fennec foxes all live in desert habitats, have very large ears and are nocturnal. **Propose** ways in which their adaptations allow them to live in their hot and dry environments.

Creating

- 14** Imagine a planet that has new environments never seen on Earth. **Construct** a group of large and small animals with adaptations that allow them to live there. **Present** your new world and animals as a Flash cartoon, a series of drawings, a cartoon strip or a set of models.

Adaptation	Survival value	Habitat
Body colour that blends with the background	Avoidance of the hottest parts of the day	Saltwater
Production of small volumes of concentrated urine	Avoids dislodgement by moving fluids	Desert
Hooks and suckers on the head end of the organism	Enables waste removal with minimal water loss	Rainforest
Broad, flat, bright green leaves	Avoidance of predators	Intestines of a sheep
Lives underground by day, and is active at night	Maximum absorption of sunlight	Any

5.1 INVESTIGATING

Investigate your available resources (for example, textbooks, encyclopaedias, internet) to complete the following tasks.

- 1** Find the Latin name for shark. Use it to propose a scientific name for Cuddles.
- 2** Research a particular environment (biome) such as a rainforest, a desert, the ocean shore or the tundra. Find:
 - the climate and special conditions experienced in the biome
 - the adaptations of plants and animals in the biome that assist in their ongoing survival.

context

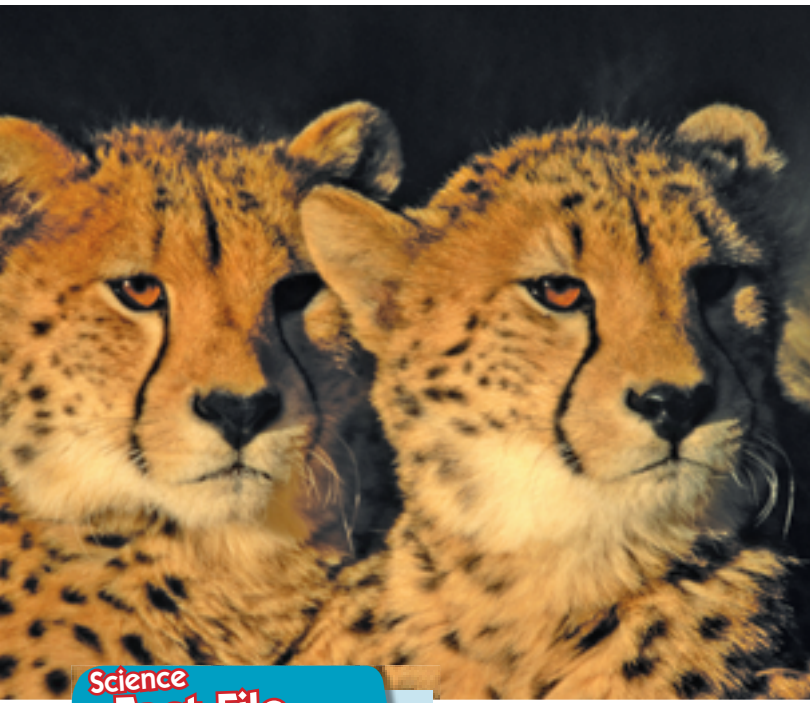

Science Fact File

Will the cheetah survive?

Cheetahs are probably more at risk of environmental change than many other animals. It seems that at some time in the past all but one mating pair of cheetahs died. Interbreeding over the generations has resulted in a homogeneous closely related population that shows very little genetic variation (the differences are about the same as are found in brothers and sisters in other species). Variation allows organisms to respond to change within their environment and so cheetahs are at risk of extinction if there is any change in theirs.

Fig 5.2.1 There is very little genetic variation among cheetahs, putting them at risk of extinction.

Natural selection

Natural selection is the process by which the environment 'selects' favourable characteristics and reduces the likelihood of unfavourable characteristics. After many generations of natural selection, a species becomes better adapted to its environment and more likely to survive and reproduce.

If the environment does not change, then the organisms that live in it become highly adapted. Variation declines and all individuals within the species become almost identical. Significant variation then only arises due to mutation.

Environments are rarely constant, however. Some changes are natural but others are due to human impact.

Evolution is the gradual development of different species from a common ancestor. Most scientists now agree that evolution occurs very slowly by a process known as natural selection.

Changes in the environment

Not all individuals in a species will survive a change to their environment. Suppose, for example, that a particular environment suddenly gets colder. There are probably some individuals that are naturally more tolerant to the cold, perhaps by having thicker coats. They will be better suited to the new, colder conditions than the rest of their species. Over time, natural selection increases the proportion of individuals with thicker coats and decreases the proportion of those without.



Observing evolution

Natural selection takes several generations before any change is evident and so it is extremely difficult to observe in large plants and animals. Each new generation seems identical to the one that came before.

Change is more obvious in organisms that reproduce quickly such as bacteria, insects and small animals like rabbits. Many generations can be observed over a relatively short time and natural selection can often be seen at work when their environment is altered. The species can be seen to change as the stronger organisms survive and the weaker ones die out.

Selection of peppered moths

The peppered moth, *Biston betularia*, is found throughout England, Scotland and Wales. There are two forms: a light-coloured form (called *typica*) and a dark-coloured form (called *carbonaria*). Until the mid-1800s, there were more light-coloured moths than dark-coloured ones. The moths lived on tree trunks covered in lichen. Whereas the light-coloured moths blended with their pale background, the dark moths were easily seen by birds, their main predator. More light moths survived and more dark moths were eaten.

During the Industrial Revolution, it was noticed that the populations of the moths had changed: there were more dark-coloured moths than light-coloured ones! Coal-burning factories were emitting huge quantities of soot which blackened nearby trees. The light-coloured moths were therefore easily seen on the blackened trunks while the dark-coloured moths were well camouflaged. Birds were eating the highly visible light-coloured moths and changing the populations.



Fig 5.2.2 Light- and dark-coloured peppered moths on a lichen-covered tree trunk



Light moths are camouflaged against clean tree trunks. Dark moths are easily seen and are therefore more likely to be eaten.



During the Industrial Revolution, tree trunks were covered in soot. Dark moths were camouflaged and the birds ate the light moths instead.

Fig 5.2.3 Natural selection at work on the populations of peppered moths



Fig 5.2.4 Around industrial areas, dark-coloured moths were most common in England, Scotland and Wales in 1950. In rural areas, there were more light-coloured moths.

The moth populations changed again when industry emissions became cleaner in the late twentieth century. Lichen began to regrow on tree trunks and the trees returned to their original paler colouring. Light-coloured moths once again became dominant. Natural selection took the moths from pale to dark and back to pale again.

Worksheet 5.1 Natural selection

Selection and rabbit control

Rabbits were initially introduced as a hunting target. They soon overran Australia, digging burrows, stripping vegetation and causing erosion. In 1950, the myxoma virus was released to control the booming rabbit population. Carried by fleas and mosquitoes, the virus caused the disease **myxomatosis**.

Soon, rabbits were dying in huge numbers. Over time, however, the virus became less effective. Fewer infected rabbits died. The rabbits were becoming virus-resistant and the virus itself seemed to be getting less effective. Natural selection was acting on both the rabbits and the virus. Within 10 years the percentage of rabbits dying from the virus had altered dramatically.

Time after release of virus	Percentage of infected rabbits dying	Percentage of all rabbits in affected areas dying
Two months	99	90
10 years	60	25

In 1950, a few of the rabbits probably had a natural, genetic resistance to the myxoma virus. These resistant rabbits survived its initial spread and their offspring would have inherited the same resistance. A healthy rabbit can produce seven or more litters of young per year and so the number of resistant rabbits would have increased quickly within a few years. The myxoma-resistant rabbits were ‘selected’ for.



Fig 5.2.5 A rabbit infected with the myxoma virus, which causes the fatal disease called myxomatosis.

Natural selection also worked *on* the virus. There are always multiple forms of the same virus. Some are highly virulent, killing quickly. Others are less virulent, taking longer to kill. The myxoma virus can multiply only within a live rabbit and so it is beneficial to the virus for the rabbit to live longer. The less virulent form was therefore ‘selected for’. The more virulent form killed too quickly for it to spread.

Go to Science Focus 3 Unit 6.3

Selection and diseases

The diseases yellow fever and malaria are carried by mosquitoes which have been traditionally controlled using chemical pesticides. Some mosquitoes were probably naturally resistant to these pesticides. Over 20 years, they bred to form populations of pesticide-resistant mosquitoes.

Science Clip

Virus attacks Akubra hats!

By the 1990s, a new virus was needed to control myxo-resistant rabbits. In 1995, while being tested in a secure facility on Wardang Island off South Australia, a virus known as Rabbit Calicivirus Disease (RCD) accidentally escaped to the mainland. Like the myxoma virus, RCD was highly effective, so much so that it spread to rabbits especially bred for Akubra hats. Akubras are made from rabbit felt and each hat requires between five and 12 rabbits!

Likewise, many bacteria are now resistant to antibiotics. Penicillin was originally very effective in treating infections caused by the bacteria *Staphylococcus aureus*, known as golden staph. Now, MRSA (methicillin resistant *Staphylococcus aureus*) is resistant to penicillin and around 20 other substances, including other antibiotics, antiseptics and disinfectants. Recently, several strains of MRSA have become resistant to the drug of last-resort—vancomycin. If vancomycin fails, the death rate from MRSA will rise dramatically.



Fig 5.2.6 An example of where MRSA has infected a surgical scar.

Speciation

A **species** is a group of organisms that normally interbreed in nature to produce fertile offspring. Dogs and cats are obviously very different species. Although they seem different, a corgi and a terrier still belong to the same species, *Canis familiaris*. They can interbreed, producing puppies that can reproduce successfully later in life. Likewise, all humans belong to the same species, *Homo sapiens*, regardless of racial or ethnic background.

The formation of a new species is called **speciation**. Speciation occurs over long periods of time and generally cannot be seen in a human lifetime or even through the recorded history of humans. Although speciation depends on natural selection, it also involves other processes such as isolation and genetic mutation. Speciation most likely proceeds in three main stages.

- **Step 1:** Geographic isolation separates a population into two groups.
- **Step 2:** Natural selection and mutation causes each group to take on its own characteristics.
- **Step 3:** Reproductive isolation ensures that the two populations cannot interbreed.

Types of evolution

Speciation provides a mechanism in which new species might arise from a common ancestor. Variations on this mechanism and different evolutionary paths have been suggested to account for the huge variety of life forms that exist now and those that have already become extinct.

Divergent evolution

The Galapagos Islands are a closely grouped set of islands off the western coast of South America. Each island differs slightly and so do the animals that live there. Fourteen species of finch, for example, have been found across the islands with each species likely to have evolved from a single ancestor. Over time, each island geographically separated the birds and natural selection did the rest. New species evolved to match each new environment. This is known as **divergent evolution**. Divergent evolution also explains the slight differences observed in the giant tortoises and iguanas that live on the islands.



Fig 5.2.7 Speciation is the creation of a new species. It most likely takes place in three main stages.

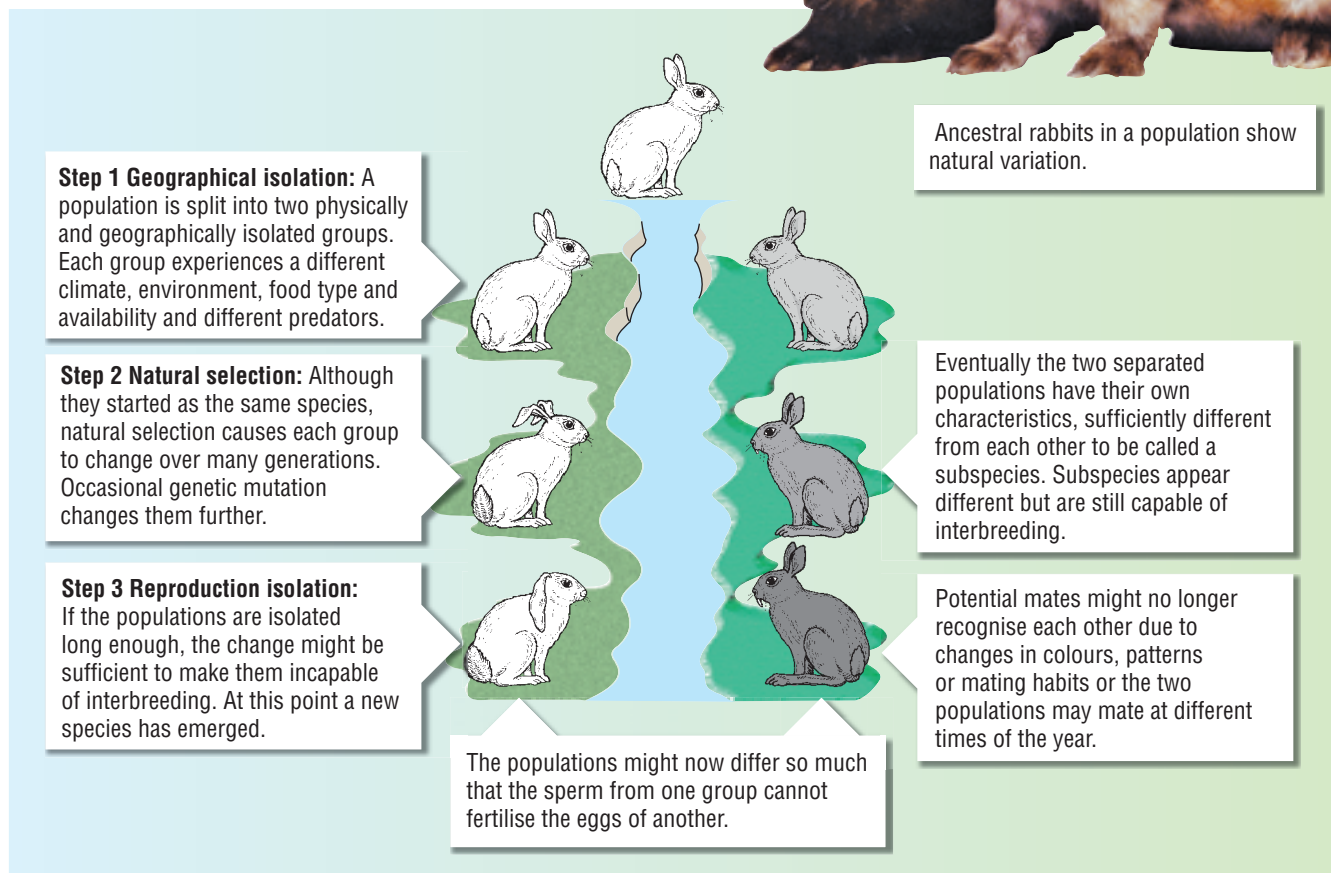

Evolution through natural selection

Sometimes the species that evolve via divergent evolution bear very little resemblance to each other, apart from their common ancestor. This is known as **adaptive radiation**: ancestral organisms become so adapted to their new environments that they evolve into completely new forms.

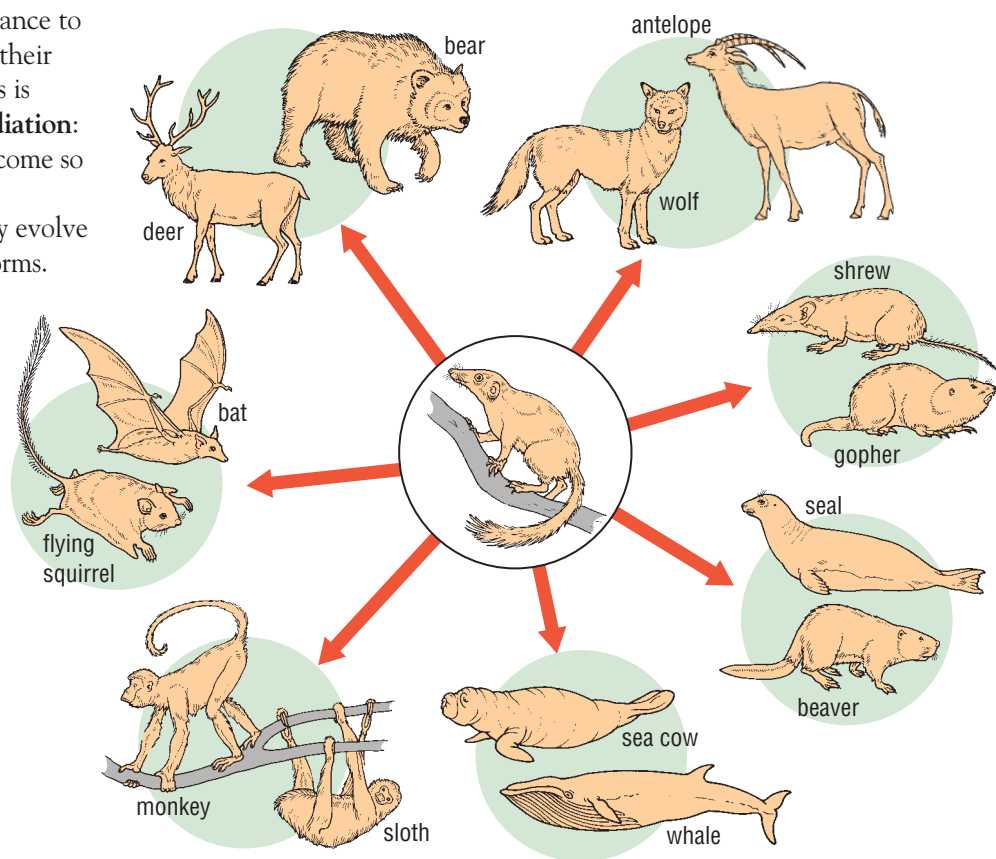

Fig 5.2.8 Mammals are thought to have evolved from the same shrew-like ancestor. This is an example of adaptive radiation.

Convergent evolution

Evolution can produce organisms that appear similar despite coming from very different ancestors. Some Australian marsupials, for example, resemble cats. Others resemble wolves, moles, mice or squirrels, despite not having a close relationship or common ancestor.

Convergent evolution occurs when organisms evolve and develop similar adaptations. This might happen because they:

- live in similar environments and habitats
- have similar lifestyles and food sources.

Analogous structures

Different organisms can end up with very similar adaptations if they need to survive in similar environments. The organisms end up looking similar, despite having very different genes passed down from very different ancestors. These organisms may even have **analogous structures**; that is, specific body parts that appear similar.



Fig 5.2.9 Australia's marsupial ancestors have evolved and radiated into many different forms. While wallabies and kangaroos still bear some resemblance to each other, possums, koalas and wombats seem to have little in common apart from a common ancestor.

Placental mammals

Marsupial mammals

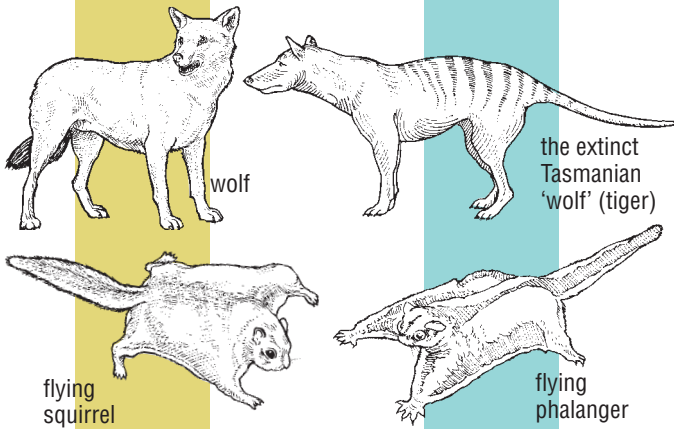

Both the wolf and the extinct Tasmanian tiger share similar food sources. Both are hunters and carnivores.

Flying squirrels and Australian gliding possums both have a membrane of thin skin between their front and rear limbs. Both are nocturnal herbivores with a similar lifestyle.

Fig 5.2.10 Australian marsupials and placental mammals from other continents have many similarities, but are not closely related. They are examples of convergent evolution.



Fig 5.2.12 Old and New World monkeys share a common ancestor and many characteristics, despite being geographically isolated. Lemurs (top photo) are a type of New World monkey with a prehensile tail. Old World monkeys such as the baboon have no tail. They are an example of parallel evolution.

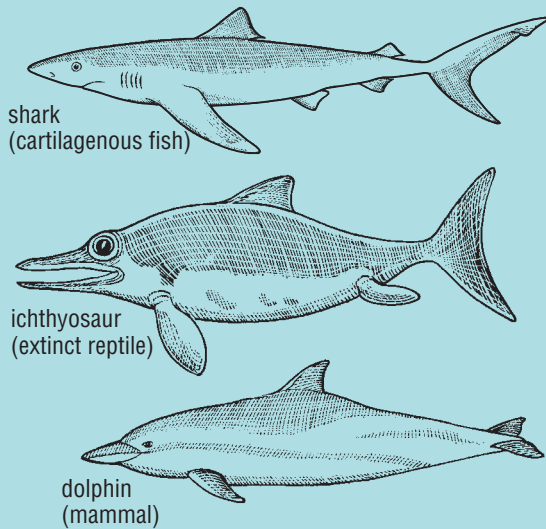

Fig 5.2.11 Convergent evolution: the shark, the extinct ichthyosaur and the dolphin have developed analogous structures (streamlined body, split tail, dorsal fin and flippers).

Parallel evolution

Parallel evolution occurs when related species are physically separated yet still evolve similar features. The organisms look alike and have common ancestry, but are found in different locations. Old and New World monkeys, for example, share many features because they come from common ancestors. Their tails, however, indicate different evolutionary paths. While New World monkeys live in the trees and have prehensile tails that hold onto the branches, Old World monkeys evolved to live on the ground and lack prehensile tails.



5.2 QUESTIONS

Remembering

- 1 State** the criteria needed for two subspecies to be classified into two different species.
- 2 List** the requirements for the following types of evolution:
 - a divergent evolution
 - b convergent evolution
 - c parallel evolution
- 3 List** analogous structures shared by:
 - a gliding possums, flying squirrels and flying lemurs
 - b sharks and dolphins

Understanding

- 4 Use** the peppered moth to **explain** what is meant by:
 - a natural variation
 - b natural selection
- 5 Use** natural selection to **explain** why:
 - a rabbits still exist despite the original effectiveness of the myxoma virus
 - b MRSA has become a major problem in our hospitals
 - c some mosquitoes have become resistant to pesticide
- 6 Explain** why a population that is very homogenous is more likely to be at risk of extinction than a population that has considerable variation.
- 7 Explain** why natural selection and evolution are difficult to observe in humans.
- 8 Describe** three events that might lead to geographic isolation of a population.
- 9 Outline** the process of speciation by rearranging the following in the order they occur:

• reproductive isolation	• further natural selection
• natural selection	• geographic isolation
• formation of a species	• formation of a subspecies
- 10** Humans have developed new breeds of domestic animals by artificial selection in a relatively short time. **Explain** why natural selection takes so much longer to develop new breeds or subspecies.
- 11 Predict** whether alpine species such as the mountain pygmy possum are likely to survive in the warmer climates caused by global warming. **Explain** your reasoning.

Applying

- 12** The Ebola virus kills its victims in a week. Death from untreated syphilis (a sexually transmitted infection) takes more than 10 years. **Identify** which is the most virulent disease.

- 13 Identify** which of the diagrams in Figure 5.2.13 best represents the processes of:
 - a divergent evolution
 - b convergent evolution
 - c parallel evolution

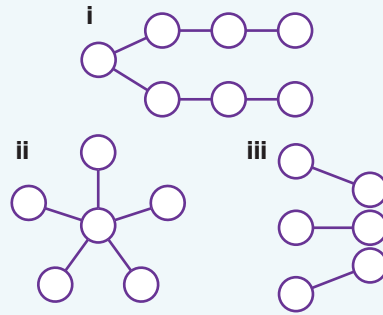

Fig 5.2.13

Analysing

- 14 Classify** the following organisms as belonging to the same species or to different species:
 - a a Japanese man and an Italian woman
 - b a German shepherd dog and a Siamese cat
 - c a Siamese cat and a Chinchilla cat
- 15 Compare** Old and New World monkeys by **identifying**:
 - a whether they come from a common ancestor or not
 - b what type of evolution they are demonstrating
 - c the feature that indicates they evolved separately

Evaluating

- 16 Predict** which form of the moth will be 'selected for' in Figure 5.2.2. **Justify** your answer.
- The African armadillo and the South American anteater have similar feet and tongues, but they are not closely related.
 - a Identify** the type of evolution that gives rise to these similarities.
 - b Propose** ways in which these similarities are explained.
- 18** Mosquitoes carrying the disease yellow fever have an acquired resistance to chemical pesticides which were once sprayed to kill them. **Propose** ways in which the gene for the chemical resistance might have originated.

Creating

- 19** Imagine global warming gets so bad that most of the Earth is covered by seas or shallow swamps and humans have evolved to cope with the new conditions. **Construct** a diagram showing what this 'evolved' human might look like. Include its likely structural, behavioural and functional adaptations.

5.2 INVESTIGATING

Investigate your available resources (for example, textbooks, encyclopaedias, internet) to complete the following tasks.

- 1 Discuss possible reasons for the evolution of Australia's unique flora and fauna.
- 2 Research the interactions between Aboriginal people and the Australian megafauna.
- 3 Research case studies of extinct and at risk species.
- 4 Describe the impact of mass extinction on species diversity.
- 5 Find out about the extensive studies that have been made of populations of brown-lipped snails, *Cepaea nemoralis*.
 - a Gather evidence from these studies.
 - b Describe how changes in these snail populations illustrate the process of natural selection.



e-xploring



To complete the simulation on the peppered moth, a list of web destinations can be found on **Science Focus 4 Second Edition Student Lounge**.

- 1 Record observations for the changes in the peppered moths.
- 2 State your deductions about the observations made.

5.2 PRACTICAL ACTIVITIES

1 Natural selection

Aim

To model natural selection

Equipment

- 100 green toothpicks (to represent green worms)
- 100 reddish-brown toothpicks (to represent brown worms)
- a grassy area and a brown earth area

Method

- 1 Draw up a results table like that shown below.
- 2 Scatter the 200 toothpicks on the grassy area.
- 3 Allow your partner (acting as a predator of the worms) 30 seconds to pick up (feed on) as many toothpicks as possible, picking up one at a time between the thumb and forefinger.

- 4 Record the number of each colour toothpick collected.
- 5 Gather up all the toothpicks.
- 6 Repeat the procedure until five 'feedings' have occurred.
- 7 Repeat the procedure on the brown earth area.
- 8 Total the numbers of each type of worm in each area.

Questions

- 1 **Account** for the differences (if any) between the numbers of 'worms' caught in each area.
- 2 This experiment is testing one factor that might affect the ability of a 'worm' to survive.
 - a **Describe** this factor.
 - b **State** three other factors that affect the survival of worms in their normal habitats.
- 3 **Discuss** the relevance of this experiment to the study of natural selection.

	Feeding 1	Feeding 2	Feeding 3	Feeding 4	Feeding 5	Total
Green worms on grass						
Brown worms on grass						
Green worms on brown earth						
Brown worms on brown earth						

context

Natural selection takes several generations before any change is evident and so it can only be directly observed in

organisms such as bacteria, insects and small animals such as rabbits. Although evolution is extremely difficult to directly observe in larger plants and animals, there is evidence that they too have gradually changed throughout their time on Earth.



Fig 5.3.1 Fossils are an excellent record of extinct organisms.



Fig 5.3.2 Sabre-tooth tigers lived in North and South America from one million to 11 000 years ago.

The fossil record

Direct evidence for evolution comes from **palaeontology**, the study of fossils. The fossil record shows that lifeforms have continually changed from 3500 million years ago until the present.

Fossils are the preserved evidence of past life, usually found in sedimentary rocks. They may be:

- actual remains of organisms (such as mammoths frozen in ice and insects trapped in a type of sap called amber)
- hard parts of organisms (such as shells, teeth and bones)
- impressions of organisms (such as hollowed casts and moulds where substances have replaced the organism)
- evidence of the presence of organisms (such as footprints and carboniferous markings on rocks).

The ages of the fossils and the rocks in which they are found can be estimated using various techniques including radioisotope-dating. These techniques have enabled scientists to devise a geological time scale that divides the history of the Earth into eras.



Fig 5.3.3 A cast of a trilobite, a marine crustacean that lived between 600 and 250 million years ago.

Fig 5.3.4 The evolution of life on Earth

Science Clip

Where are we?

Eras are subdivided into periods. For example, the Mesozoic era is subdivided into the Triassic (the oldest), the Jurassic and the Cretaceous periods. The dinosaur *Tyrannosaurus rex* lived in the Jurassic period of the Mesozoic era. We currently live in the Quaternary period of the Cenozoic era.

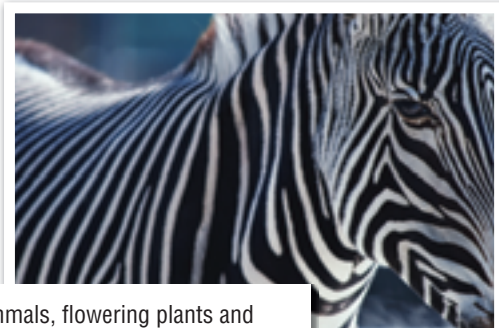

Mammals, flowering plants and birds appear with increasing dominance of the mammals.

The age of the reptiles—abundant and diverse reptilian forms include the dinosaurs.

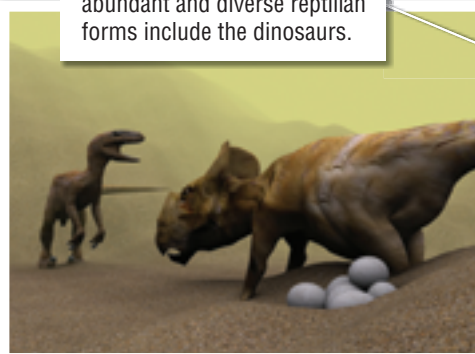

First invertebrate animals appear. Ediacarans possibly related to jellyfish and earthworms.



Humans appear around 200 000 years ago.

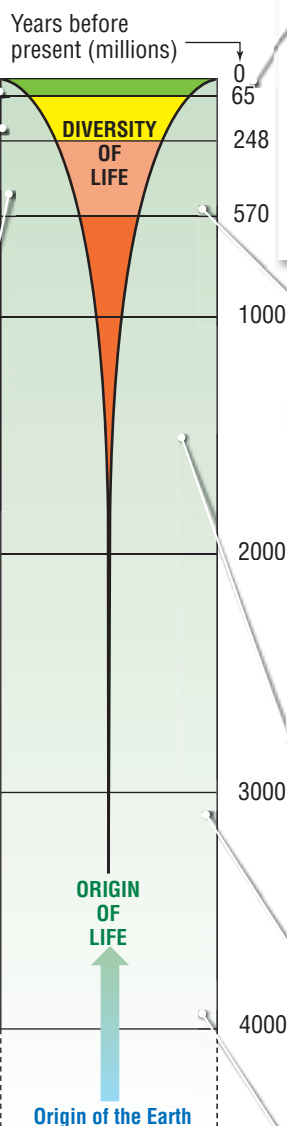

Bacteria, algae and soft-bodied invertebrates exist. Trilobites are abundant. About 400 million years ago, first land plants appear. Land amphibians appear slightly later.



Sexual reproduction begins around 1500 million years ago. Organisms with more complex cellular structures appear.

Photosynthetic bacteria and blue-green algae appear, releasing oxygen into the atmosphere. This release allows ozone (O₃) to form and accumulate, screening out some of the ultra violet (UV) radiation. This gives some protection to the newly evolving organisms.

Organic compounds form. Simple, single-celled bacteria appear around 3500 million years ago. The bacteria are anaerobic as no oxygen is available. They feed on organic compounds in the primitive seas.

- Pre-Cambrian
- Palaeozoic
- Mesozoic
- Cenozoic

Using the fossil record

The fossil record traces the history of life on Earth since it began around 3500 million years ago.



Fig 5.3.5 A living fossil—Coelacanths, the ancestors of which are thought to have given rise to amphibians, have remained unchanged for 400 million years.

A changing record

The fossil record provides evidence of continual change. Those earliest life forms have spread and diversified into the vast number and variety of species that are now on Earth. Whole groups of organisms have appeared, become abundant and then disappeared. Two of the most dramatic changes that have brought extinction have been:

- dramatic climate change and altered sea levels—these may have caused the disappearance of 50 per cent of all shallow water marine invertebrates around 225 million years ago
- the impact of a large asteroid and the dust storms it created—these are thought to have caused the extinction of the dinosaurs around 65 million years ago. The number and variety of mammals increased dramatically after the extinction of dinosaurs.

Science Fact File

How did it all begin?

At the University of Chicago in 1953, a student named Stanley Miller passed electrical sparks through a mix of gases that were thought to make up the early atmosphere of Earth (methane, CH_4 , ammonia, NH_3 , hydrogen, H_2 and water vapour H_2O). After a few days it formed a concentrated 'soup' of amino acids, fatty acids and sugars. Although complex organic molecules like these are the basis of life, no living cells were produced.

An incomplete record

The fossil record is far from complete. Only a small proportion of the plant and animal species that are thought to have existed are preserved as fossils. While the fossil history of aquatic organisms is extensive and detailed, the fossil history of land animals is far less so. This lack of fossils on land is not surprising because **fossilisation** is a rare occurrence. To become fossils, organisms must die in conditions where decay does not occur. The soft tissues of organisms usually do not form fossils. Fossilisation is more

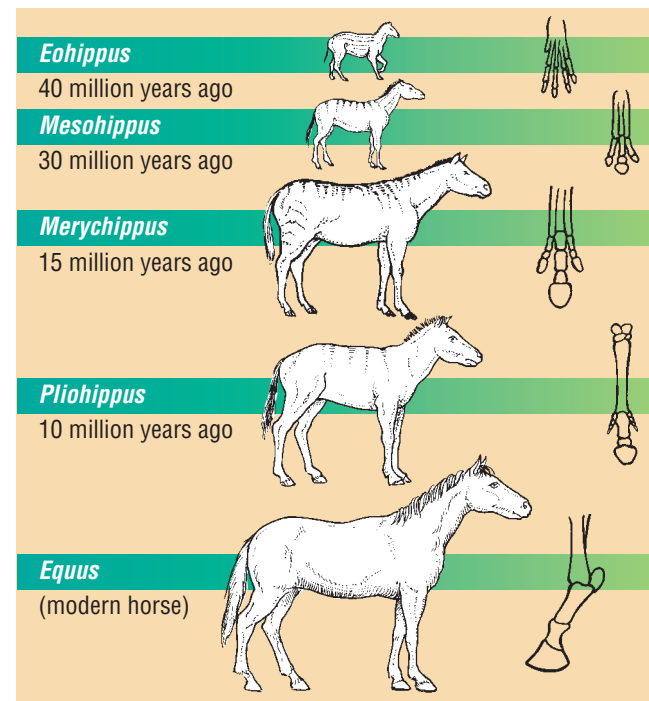

Fig 5.3.6 Fossils provide an excellent record of the evolutionary development of the horse. Evolution has caused some toes on the horse to shorten until they eventually disappeared. Other toes formed a hoof.

Worksheet 5.2 Evolution of the horse

Science Clip

Introducing beaver-otter-platypus

The fossil record is continually amended as new fossils are found. Until recently, most scientists believed that the mammals of the Mesozoic era were small and shrew-like and did not spread until after the extinction of the dinosaurs. A fossil discovered in China in 2004, however, indicates that mammals may have been bigger and may have spread across Earth much earlier. The 50-centimetre-long skeleton is about 164 million years old and is of a mammal that had a broad beaver-like tail, otter-like teeth and a platypus-like lifestyle. It dog-paddled in water and burrowed tunnels on land. Links are often missing in the evolutionary stories of many organisms. This doesn't mean they do not exist but usually means that they have not yet been found.



Fig 5.3.7 This is the 170 million-year-old fossil remains of *Archaeopteryx*, a flying reptile with feathers. *Archaeopteryx* is a transitional form providing a link between reptiles and birds. Another transitional form is an air-breathing crossopterygian fish that lived 400 million years ago.



Fig 5.3.8 The mudskipper is an amphibious fish found in Africa, Asia and Australia that has adaptations that allow it to live both in water and in mud. This fish shows how fish may have first emerged from the waters to live instead on land.

likely in seas, lakes, swamps and caves, but unlikely on land. Geological processes and human activity are constantly moving and destroying the sedimentary rocks that contain fossils.

Transitional forms

Transitional forms provide the missing links in certain evolutionary pathways. Modern vertebrates, for example, appear to have evolved first as jawless fish, then bony fish, then amphibians, reptiles, birds and finally mammals.

For many groups of organisms there are large gaps in the fossil record because no transitional forms have been found. However, this cannot be taken as proof that the fossils of transitional forms do not exist. It is possible that:

- fossils may be out there undiscovered
- fossils may have been found but have not been recognised as important
- the transitional forms may have developed in a population and an area too small or inhospitable for fossils to develop. This is possible as speciation is most likely to occur in a small, isolated population with a changing environment.



Evidence from other studies

Homologous structures

The front flipper of a seal, a cat's paw, a horse's front leg, a bat's wing and a human hand all look different and perform different functions. Despite this, they all consist of the same number of bones, muscles, nerves and blood vessels arranged in a similar basic pattern. All vertebrates have what is known as a **pentadactyl limb** structure (a limb with five digits). Each limb has become adapted to meet a specific need in that animal's environment. A bat has longer 'fingers' allowing them to be opened to make a wing. The horse has progressively lost its toes so that it now walks on its third toe which has become its hoof.

The basic pentadactyl limb can be traced back to the fins of certain fish from which the first amphibians are thought to have evolved. These fundamentally similar structures are called **homologous structures**.

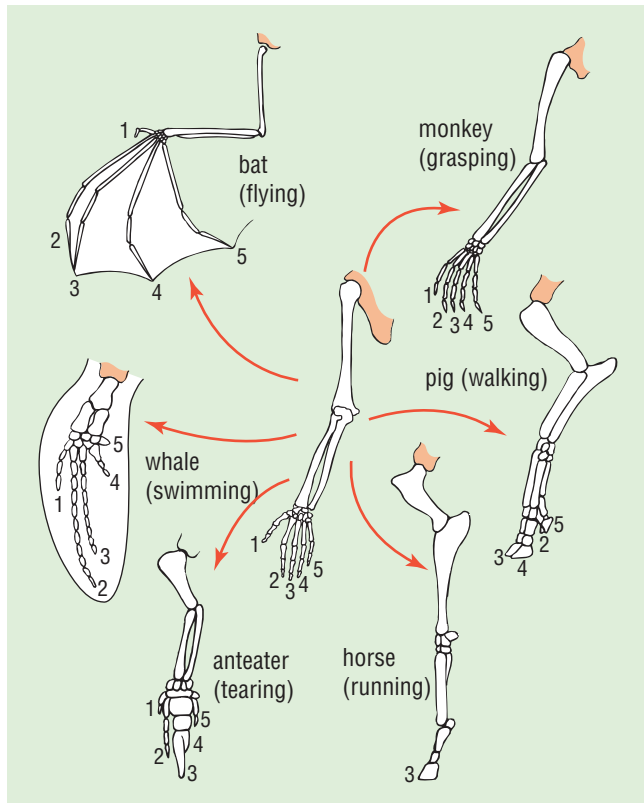

Fig 5.3.9 Pentadactyl limbs are homologous structures. Animals that share them have probably evolved from a common ancestor.

Useless structures

A number of structures, such as the human appendix and the muscles near the ears, have no apparent function. They are called **vestigial organs**. It is thought that they had some function in our ancestors, but that evolution has reduced these structures so much that they are no longer functional. They provide no advantage or disadvantage and so humans still have them today.

Embryonic development

The development of **embryos** provides further evidence of evolution. During its development, the human embryo resembles the embryos of different animals. Early on it resembles a fish embryo with gill slits, a tail and a fish-like heart and kidney. Its heart and kidney soon change to a more reptile-like form. At seven months old, it is covered with hair and has the body proportions of an ape. These developmental stages are thought to reflect its evolutionary history and suggest a common ancestry with fish, reptiles and apes.

Fig 5.3.10 Different embryos share certain characteristics indicating that they may share a common ancestor.

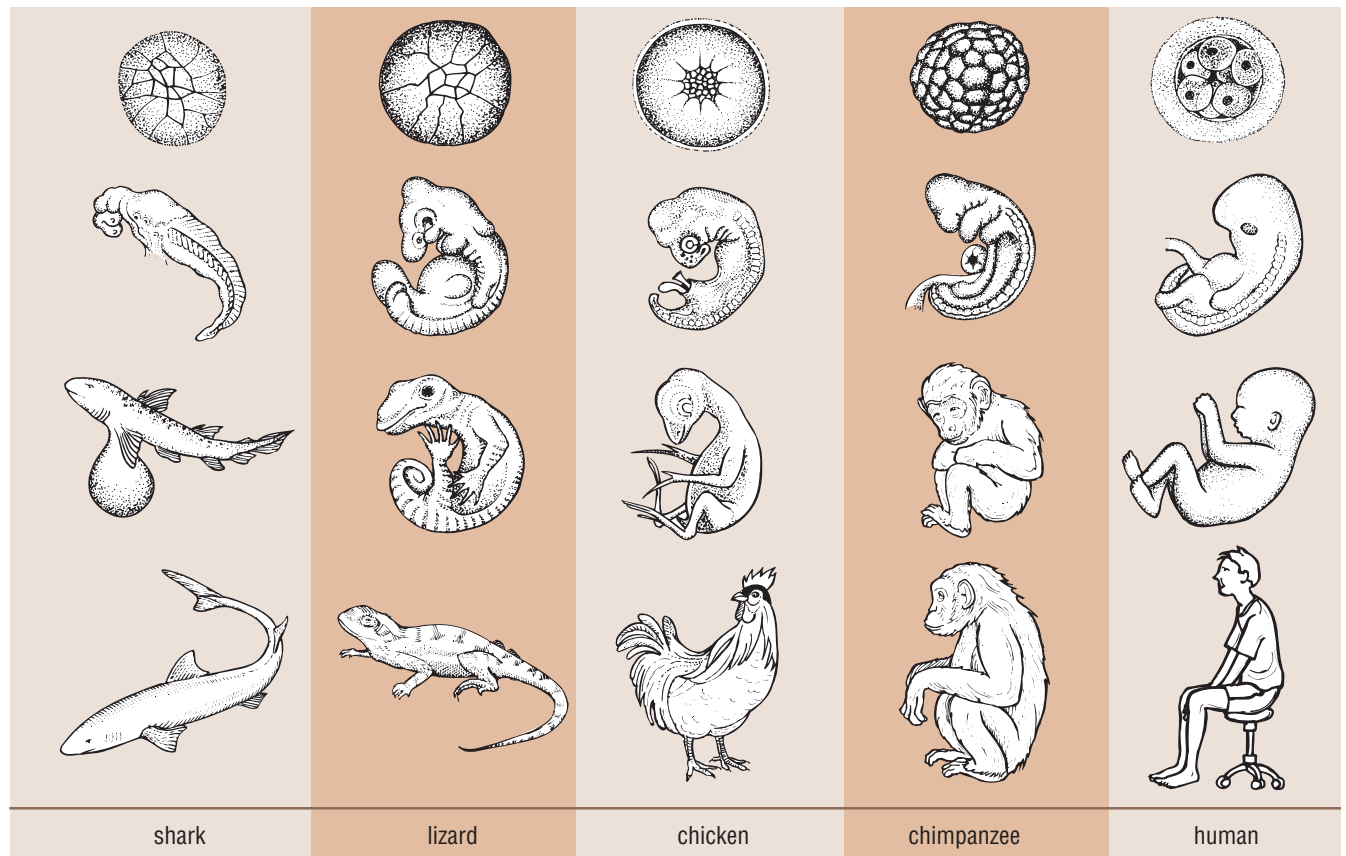

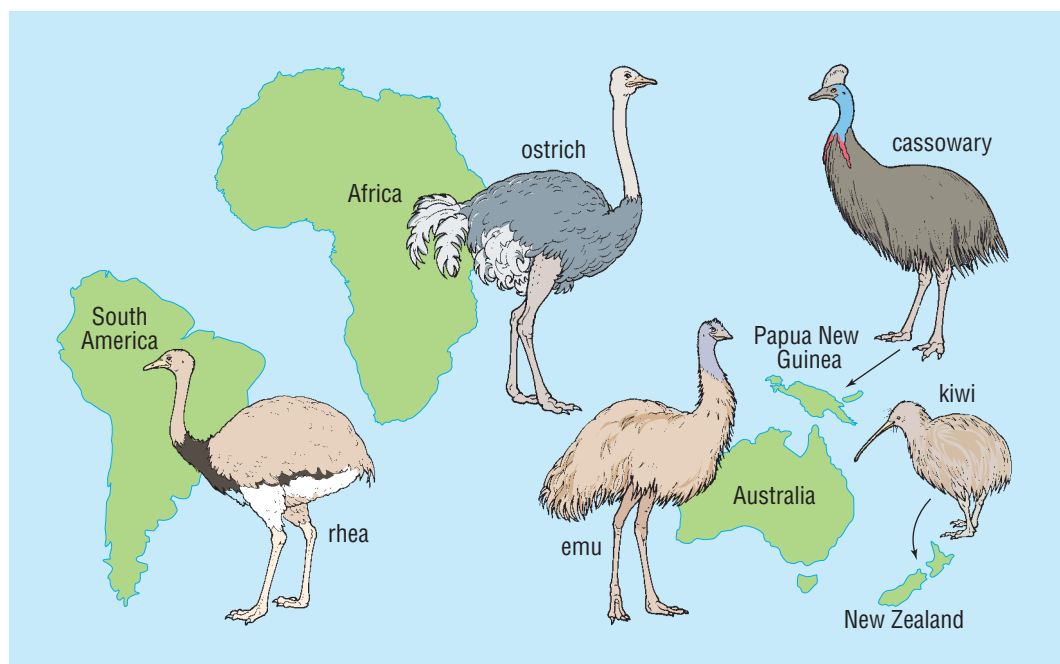

Fig 5.3.11 The flightless birds of the southern continents are related in many of their characteristics and in much of their DNA.

Distribution of plants and animals

DNA shows that the flightless birds of the southern continents are all related. It is now known that the southern continents were once joined as a supercontinent called **Gondwana**. Gondwana split into pieces that then drifted (and are still drifting) into their current places. The flightless birds went with their continents, carrying their ancestral DNA with them. DNA studies show the emu to be most closely related to the cassowary, with the kiwi a second cousin. The rhea and ostrich are more distantly related. This matches the order in which the continents are thought to have separated.

Genetic evidence

The structure of **DNA** and the **genetic code** provide more evidence for evolution. The code is universal. Apart from some viruses, all organisms use the same basic code. This suggests that all living things are related and have evolved from common ancestors. Comparisons of DNA are used to provide evidence of how closely different species are related. For example, the genetic make-up of a chimpanzee is 98.5 per cent identical to that of a human. Gorilla DNA has a 95.4 per cent match with human DNA. The genetic make-up of other primates is also similar to humans.

Gene duplication

Gene duplication is when an organism produces an extra gene for a particular characteristic. While mammals produce milk, reptiles do not. Mammals produce protein X, a protein also found in reptile eggs.

The milk protein is also very similar to protein X. It implies that an error occurred when an ancestral reptile cell split. While it should have produced two genes and with both producing protein X, one of the genes mutated to produce milk instead.

Biochemistry

The biochemistry of different organisms is very similar. All animals and plants have similar:

- chemicals (for example, the energy-carrying molecule ATP)
- functional parts or organelles in their cells (for example, mitochondria)
- chemical reactions (for example, respiration).

Amino acids and the proteins they form measure how closely two organisms are related. If two organisms shared a recent ancestor, then there will only be a few differences in the sequences of amino acids in their proteins. The longer ago two species had a common ancestor, the more likely the chance for mutations to happen in their genes and the greater the difference in these sequences.

There are 340 amino acids in the molecule called haemoglobin that carries oxygen in the blood and their sequence is identical in both humans and chimpanzees. Gorillas are different in only two amino acids while monkeys are different by 12. This evidence supports the idea of evolution due to mutation and natural selection.

Science Clip

A bird with teeth?

Birds do not have teeth and have not had them for the last 60 million years. In an experiment, tissue from the mouth of a mouse embryo was placed into the mouth tissue of a chicken embryo. After incubation, the chicken began to grow teeth! Not like mouse teeth, but like those of the oldest known feathered fossil. Modern birds obviously still have genes coding for making teeth. All they appear to lack is the mechanism to 'switch on' these genes.

5.3 QUESTIONS

Remembering

- List four different types of fossils.
- List reasons why fossils are relatively rare.
- Name an animal that has plenty of fossils recording its evolution.
- Based on DNA studies, name the organism that:
 - humans are thought to be most closely related to
 - humans would be least closely related to
- Recall the timeline of evolution by matching the events with their proposed time of occurrence.

Event	Time (millions of years ago)
Life on Earth begins	0.2
First land organisms appear	4500
Humans first appear	1500
Complex cellular structures appear	3500
Dinosaurs become extinct	600
Earth forms	65
First animals appear	400

- List two dramatic events that have changed the fossil record.
- State how many digits a pentadactyl limb normally has.
- List three pieces of evidence from biochemical studies that support the theory of evolution.

Understanding

- Define the term palaeontology.
- Coelacanths are considered to be living fossils. Explain why.
- Outline why *Archaeopteryx* is considered to be a transitional form in the evolutionary pathway of vertebrates.
- Describe what vestigial organs are and how evolution explains them.
- All mammals have some form of pentadactyl limb. Explain what this indicates.
- List two transitional forms and explain why they are important.
- Describe how DNA supports the theory of evolution.
- Clarify what is meant by 'gene duplication'.
 - State how gene duplication could arise.
 - Propose a way in which gene duplication contributes to the evolution of organisms.

- Describe how embryological studies support the idea of evolution.
 - Outline what is meant by 'homologous structures'.
 - State how homologous structures are useful in the study of evolution.
- The map in Figure 5.3.12 shows the distribution of members of the family Proteaceae, a group of plants that includes banksias and proteas. Species of the genus *Banksia* are found only in Australia and New Guinea. Species of the genus *Protea* are native only to South Africa.



Fig 5.3.12

- Explain why the family Proteaceae has the southern distribution shown.
- Explain why different types (*Banksia* and *Protea*) are found on different continents.

Analysing

- A shark and a dolphin have analogous structures while an ape and a human have homologous structures. Contrast analogous with homologous structures.
- Analyse the calendar in Figure 5.3.13 on page 187.
 - Name the four eras in the geological time scale.
 - State how many days each era represents on the calendar.
 - State the 'dates' on which the following occurred:
 - life begins
 - dinosaurs become extinct
 - humans appear

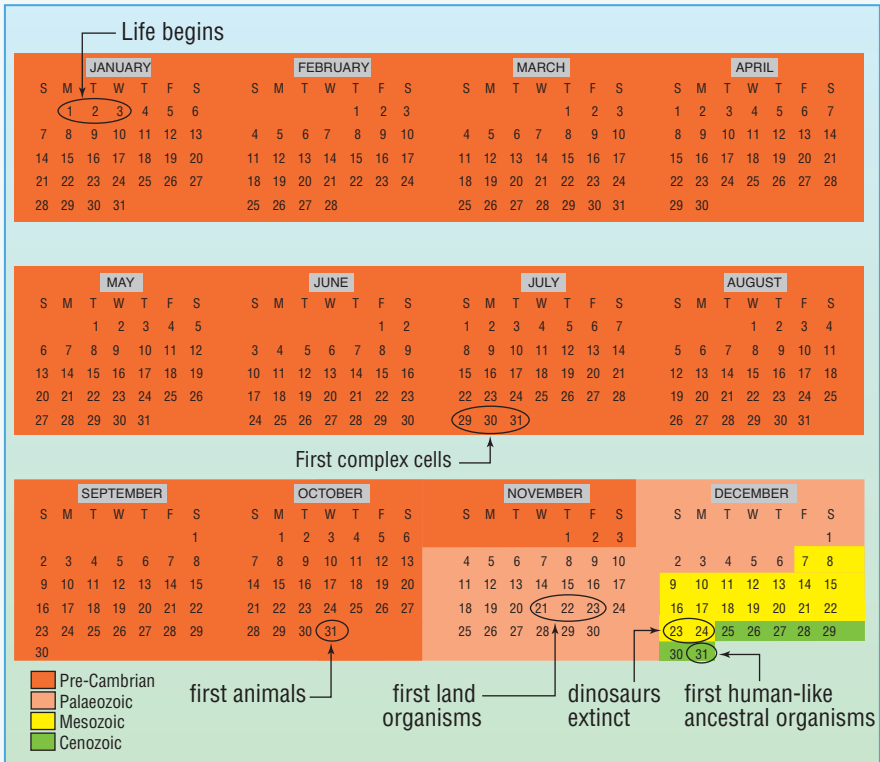

Fig 5.3.13

Evaluating

21 The fossil record of the camel family is relatively complete. Distribution of fossils suggests that they migrated as shown in Figure 5.3.14.

a Identify if they originated from a common ancestor. If so, where did they originate?

b The map shows their migration route around the world. **Explain** why they would have evolved differently on different continents.

c Identify whether the different types of camel would be able to breed together. **Justify** your answer.

d Propose which type of evolution is being shown here.

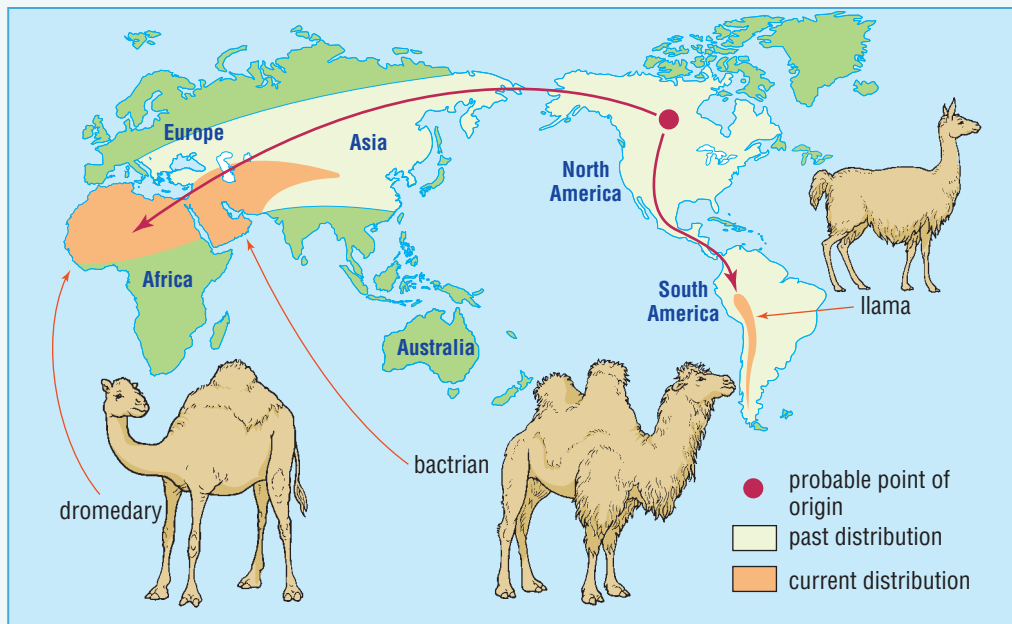



Fig 5.3.14

5.3 INVESTIGATING

Investigate your available resources (for example, textbooks, encyclopaedias, internet) to complete the following tasks.

- 1 Examine the origins of Australia's marsupials.
- 2 Write a report to account for the fact that marsupials are widespread in Australia but almost non-existent elsewhere. 
- 3 Find how fossils suggest that the ear bones of mammals have evolved from the jaw bones of reptiles. Research this strange

evolutionary story and write a report analysing the information, and identifying problems with this story.

e-xploring



To complete the activities on the evolution of the horse, a web destination can be found on **Science Focus 4 Second Edition Student Lounge**. View the 'Amazing Feets' link to learn about the evolution of the horse.

5.3 PRACTICAL ACTIVITIES

1 Studying fossils

Aim

To study fossils and identify how each was formed

Equipment

- access to a fossils kit

Method

- 1 Select a fossil and draw it as accurately as you can.

- 2 Underneath your drawing, write its name, the period and era it comes from and a brief description of what it is (animal, plant, fern, etc.).
- 3 Identify what type of fossil it is (bone, shell, mould or cast, footprint, carbonised, etc.).
- 4 Repeat for the other specimens.

Question

Construct a timeline of the fossils you investigated.

2 Constructing fossils

Aim

To construct, bury and unearth a model 'fossil' and to determine if a realistic creature can be constructed from it

Equipment

- chicken or rabbit carcass
- cooking implements (e.g. saucepan, hotplate)
- bleach
- plaster
- mud or clay

Method

- 1 Construct a fossil using bones. To prepare bones for use:
 - thoroughly cook a chicken or rabbit carcass
 - strip any meat from the bones
 - soak the bones overnight in detergent to help remove any remaining meat pieces

- bleach the bones by soaking overnight in a bleaching liquid
- dry the bones in the sun.

- 2 Use the prepared bones to build a 'fossil' of an animal that does not resemble the chicken or rabbit from which they came.
- 3 'Bury' the bones in wet plaster, mud or clay.
- 4 When set, swap fossils with another group.
- 5 Carefully break apart the fossil and try to re-construct the fossilised creature.

Questions

- 1 **State** whether you were able to 'unearth' the bones without breaking them.
- 2 **State** whether you were able to construct a complete skeleton from the set of bones.
- 3 **State** whether there are alternative ways to putting together the bones.

context

The fossil record suggests that humans evolved from a common ancestor just like all the other animals on Earth. However, there is considerable and ongoing debate among scientists about how humans evolved.

An even more fierce debate continues between scientists and those who believe that humans have not evolved, but were created by a god or gods.

Primates

Modern humans (*Homo sapiens*) belong to the order **Primates** and have the same features as others in the primate group. Primates have:

- forward-facing eyes that allow binocular vision
- pentadactyl digits (five fingers or toes on each limb)
- four upper and four lower incisor teeth
- opposable thumbs (for grasping things)
- nails (not claws) on the fingers and toes
- large brains for their body size
- a flexible skeleton, with arms that rotate in the shoulder socket to allow them to reach behind their body.



Fig 5.4.1 Humans and chimpanzees are closely related. Both are primates.

Fossil evidence suggests that primates arose from tree-dwelling, shrew-like insectivores around 50 million years ago. This group soon split into several divergent lines of evolution, giving rise to the modern-day primates. These are the prosimians (pre-monkeys, similar to lemurs), New World monkeys, Old World monkeys and hominoids.

Fig 5.4.2 Like humans, orangutans are highly intelligent. They use tools and have distinct social structures. They live in the rainforests of Indonesia and Malaysia where their name means person of the forest.

Science Fact File

Homo sapiens

As *Homo sapiens*, humans also:

- walk upright (are bipedal)
- have fewer and smaller teeth than apes
- have a flattened face
- have a very large skull capacity and a large brain, about three times larger than that of apes
- make and use tools
- use various verbal and visual languages to communicate
- are self-aware.

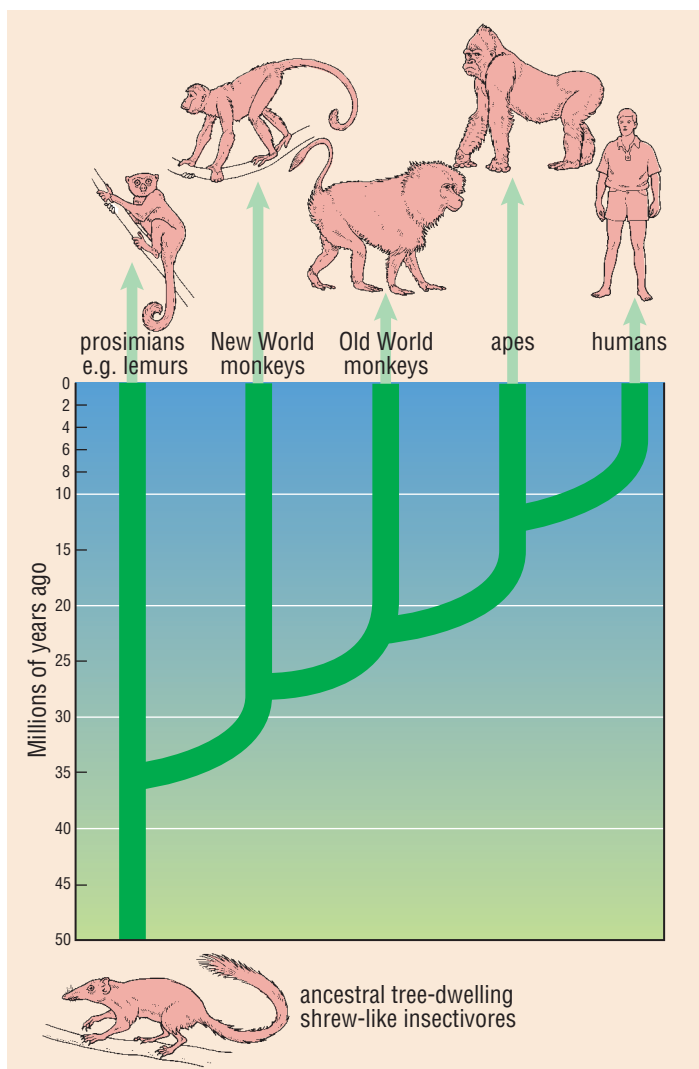

Fig 5.4.3 This is the probable evolutionary tree for primates. The branches might appear a little confusing as the New World monkeys are older than the Old World monkeys! Here, 'Old World' refers to those parts of the world long known to the Europeans; that is, Europe, parts of Africa and parts of Asia. 'New World' refers to those parts discovered later by Europeans (predominantly North and South America).

Evolution of humans

The most recently evolved group of primates is called the **hominoids**. The hominoids include the lesser apes (gibbons), great apes (gorillas, chimpanzees and orangutans) and humans. The earliest humans almost certainly arose from the same common ancestor as the other hominoids. Although they have similar ancestors, apes and humans are very distantly related, taking different evolutionary pathways millions of years ago.

Relatively few human fossils have been found and so the human evolutionary process is not definitely known. There is no accurate record of when modern humans emerged, and the exact relationships linking the few existing fossil remains to today's humans are controversial.

Our distant relatives

The picture we have of the common ancestor of modern apes and humans is largely based on the fossils of *Dryopithecus*, an ape-like animal, which first appeared 25 million years ago. *Ramapithecus*, another ape-like animal, appeared 14 to 16 million years ago, lasting another six million years. Some believe *Ramapithecus* to be the ancestors of the orangutan, while others see a relationship to other apes and humans. There are significant gaps in the fossil records of five to eight million years ago.

Southern ape

Although apes and humans had similar ancestors in the past, the *Homo* line diverged from the apes. The first true 'human-like' fossils belong to the genus *Australopithecus* (meaning 'southern ape', after the first fossils found in South Africa). The oldest known fossils, *Australopithecus afarensis* (*A. afarensis*), are around four to five million years old.

A. afarensis is most likely to have evolved into a number of new species, including *A. africanus*, *A. robustus* and *A. boisei*. These species were bipedal (walked on two legs) and had a brain size of 400 cm³, less than one-third that of modern humans (approximately 1450 cm³). All fossils of *Australopithecus* have been found in Africa.

Recent finds indicate that some australopithecines lived alongside the early members of the genus *Homo* (the genus to which modern humans belong). This suggests that *A. afarensis* is the ancestor of both the *Homo* and *Australopithecus* lines.

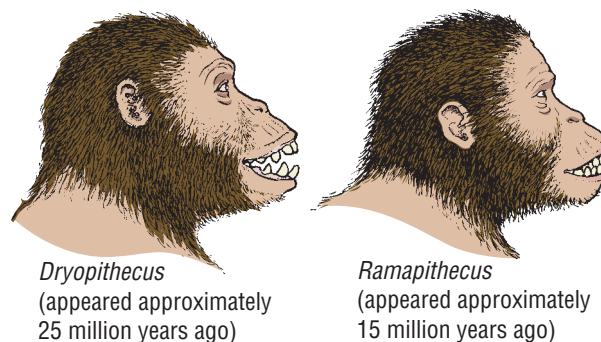

Fig 5.4.4 *Dryopithecus* and *Ramapithecus*—possible ancestors of modern apes and humans

Science Clip

Evolving Beetles

One of the most famous and intact of the *Australopithecus* fossils is the skeleton of a female named Lucy. Lucy is 40 per cent complete and was discovered in 1974. She was named after The Beatles hit song 'Lucy in the Sky with Diamonds'.



Science Fact File

Australopithecus

It is believed that *Australopithecus*:

- occasionally walked, but spent considerable time climbing in trees
- ate fruit, seeds, insects and roots
- is unlikely to have used tools more advanced than a stick.

More recent ancestors

The first clear representation of the *Homo* line is *Homo habilis* (handy man). Fossils aged 1.5 to 2 million years old found in East Africa reveal major changes in anatomy (a brain 50 per cent larger) and behaviour (they used tools) from *Australopithecus afarensis*.

Homo erectus (upright man) came next. Although fossils have been found in Europe, China and Africa, *Homo erectus* is often called Java man, after the initial discovery site. The oldest are 1.5 million years old. Average brain size was 1000 cm³.

Science Fact File

Homo habilis

It is believed that *Homo habilis*:

- had a brain 50 per cent larger than *Australopithecus*
- probably scavenged meat from kills by other animals
- was the first to make stone tools.

Fig 5.4.5 An artist's impression of *Australopithecus afarensis*

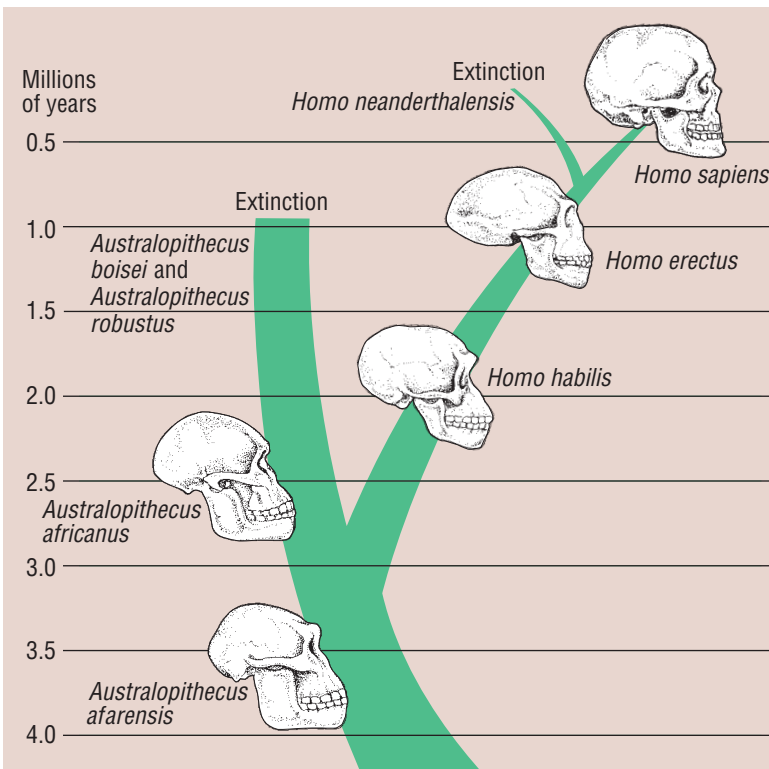
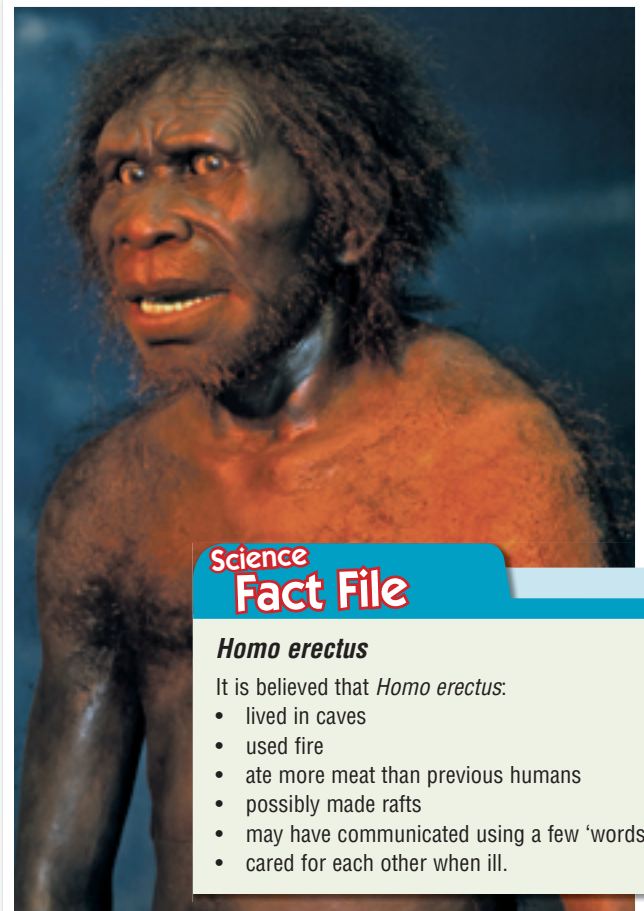

Fig 5.4.6 The likely family tree for humans



Science Fact File

Homo erectus

It is believed that *Homo erectus*:

- lived in caves
- used fire
- ate more meat than previous humans
- possibly made rafts
- may have communicated using a few 'words'
- cared for each other when ill.

Fig 5.4.7 A model of *Homo erectus*, Java man

Human evolution

The evolution of *Homo erectus* to *Homo sapiens* (intelligent man) is the subject of considerable debate. Some maintain that *Homo erectus* evolved worldwide to *Homo sapiens*, but retained local features. This gave rise to different forms in different areas, such as Asia and

Africa. Others maintain that *Homo sapiens* evolved in Africa and spread from there some 200 000 years ago. This would mean that all present-day variation in humans has arisen only in the last 200 000 years.

Science Clip

How do we know all this?

Much of the information about *Homo erectus* came from the skeleton of a boy called the Turkana boy. He had a shorter intestine and smaller abdomen than earlier humans, indicating he ate more meat than them. This also implied the use of weapons to hunt and fire to cook. Another *Homo erectus* skeleton showed she was crippled but survived, suggesting that someone looked after her.

Science Clip

The seven daughters of Eve

Mitochondrial DNA is a peculiar form of DNA that is passed directly from mother to child. It can therefore be used to trace a chain of female ancestry. Using this method, a geneticist at Oxford University, Brian Sykes, has proposed that 90 per cent of Europeans can trace their maternal ancestry to one of only seven women. The most distant of these seven lived 45 000 years ago and the most recent 10 000 years ago. Sykes supports the idea of a relatively recent expansion of *Homo sapiens* from their African origin.

Other fossil humans

There are other species of the *Homo* line that have been identified.

Homo neanderthalensis (Neanderthal man) is thought to have lived approximately 35 000 to 100 000 years ago. Neanderthals are thought to have become extinct due to a change in climate or through competition with other human species in Europe. The common ancestor of humans and Neanderthals probably lived in Europe around 600 000 years ago.

Cro-Magnons lived about 10 000 to 40 000 years ago in Europe and were nomadic hunter-gatherers. They were anatomically similar to modern human, but more robust. The exact reasons for their extinction are not known.

Science Fact File

Homo neanderthalensis

It is believed that *Homo neanderthalensis*:

- were cave dwellers
- used tools such as blades and spears
- used fire
- buried their dead, indicating some religious beliefs
- may have communicated using sentences
- lived until about 40 years old.

Science Fact File

Cro-Magnons

It is believed that Cro-Magnons:

- used tools such as rope and antler or bone fishhooks and net-sinkers
- developed art, decorating themselves with necklaces and precious stones
- crafted sculpture and cave paintings
- traded with others using precious stones
- buried their dead along with goods for the afterlife
- lived until about 60 years old.

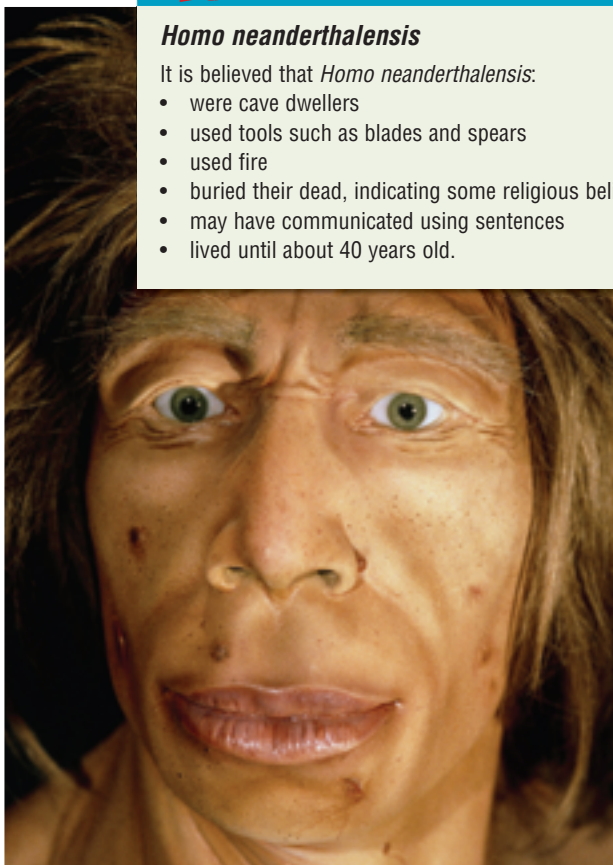

Fig 5.4.8 A model of Neanderthal man

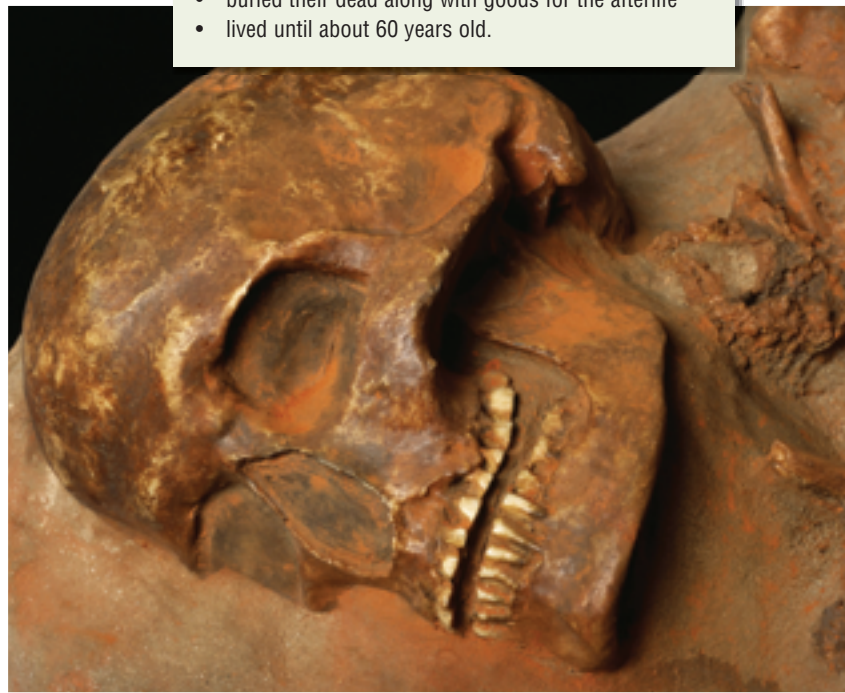

Fig 5.4.9 A Cro-Magnon human from the Czech Republic

Anatomical changes

Whatever the exact pathways were in the evolution from ape-like ancestor to modern human or *Homo sapiens*, some changes are clear:

- the various forms walked more upright than their ancestors

- they developed smaller teeth, reduced eyebrow ridges, shorter arms, flatter feet and non-opposable big toes
- they developed flatter faces and a progressively larger brain size.

Science Clip

A convincing hoax

The skull of 'Piltdown man' was discovered in a grave pit in southern England in 1912. It had an ape-like jaw, with a large, modern-looking cranium. The scientific world was excited by the find, particularly the English, who thought that the first man was one of them. It was not until 1955 that the skull was revealed as a forgery—a human skull joined to an orangutan's jaw and treated to give an aged look.



Fig 5.4.10 Fossilised human skulls: note the changes in face shape and skull capacity. **A** *Australopithecus africanus* **B** *Homo habilis* **C** *Homo erectus* **D** Cro-Magnon (about 22 000 years old) **E** A 'modern' human, *Homo sapiens* (around 92 000 years old)

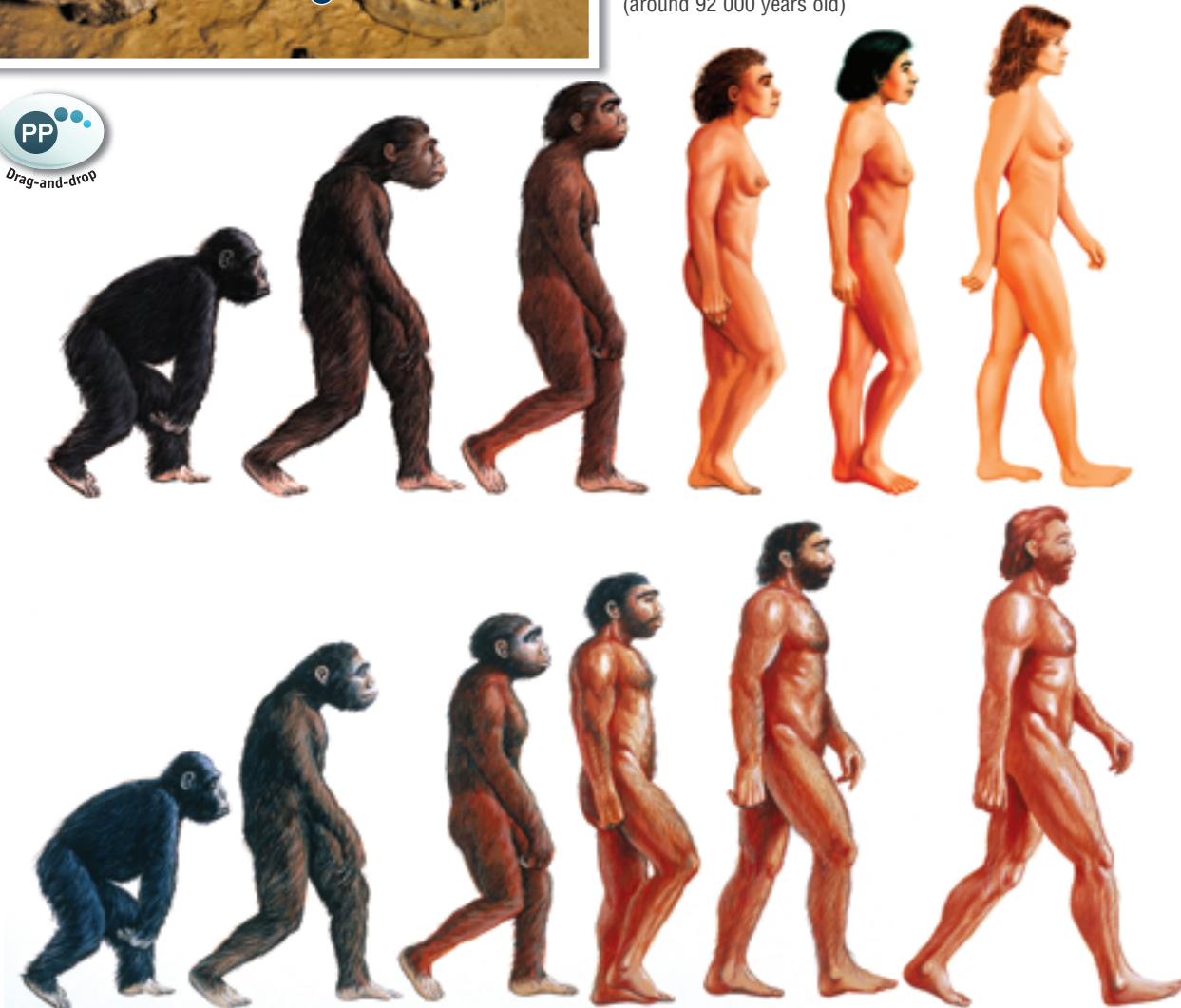

Fig 5.4.11 How humans have changed through evolution

Cultural evolution

Humans have changed in many non-physical ways. We have learned how to use tools, and have developed speech, forms of writing, artistic creativity, reasoning powers and a sense of right and wrong. It is these changes that most distinguish modern humans from their ancestors. Humans have highly complex social structures and an accumulation of learning and knowledge. This stored experience is passed from generation to generation, and affects our survival. This is **cultural evolution**.

It is estimated that of all the animal species that have ever existed, only one per cent are alive now. The ultimate fate of most species appears to be extinction. *Homo habilis* lasted for around one million years, *Homo erectus* around 1.5 million. Modern humans have existed for about 200 000 years. With cultural evolution, humans continue to acquire knowledge, enabling us to exert more control over our environment than any other species ever has, but we have probably done more damage also. What does this mean for the future of *Homo sapiens*?

 **Worksheet 5.3** The 'Hobbit'

Science Clip

Fire starter

Fire is probably the most important tool that humans have learnt to control and use. Aboriginal people in Australia traditionally used fire to hunt and manage the land. The knowledge of using fire, and the skill of starting a fire, is passed from one generation to the next. This is an example of cultural evolution.



Fig 5.4.12 Cultural evolution: the knowledge of fire is passed from one generation to the next through practice and observation.

5.4 QUESTIONS

Remembering

- 1 List the characteristics of primates.
- 2 Various features distinguish humans from the other primates. List two examples each of distinguishing features that are:
 - a physical
 - b non-physical
- 3 List five examples of hominoids.
- 4 List three physical changes marking the evolution of humans from an ape-like ancestor.
- 5 Recall the different types of humans by copying and completing the table on page 195.

Understanding

- 7 Explain the importance of a 50-million-year-old shrew-like insectivore to humans.

- 8 a Describe what is meant by cultural evolution.
- b Describe two examples of cultural evolution in action.

Applying

- 9 Identify what distinguishes hominoids from the rest of the primates.
- 10 Identify the advantages that the following give to a primitive hominoid:
 - a the ability to sharpen sticks
 - b the ability to throw rocks
 - c social groupings
 - d caring for their sick and wounded
 - e the ability to trade
 - f the ability to communicate more than a few words

	Ape-or human-like?	Alternative name	Years of existence	What they did/could do
<i>Dryopithecus</i>				
<i>Ramapithecus</i>				
<i>Australopithecus</i>				
<i>Homo habilis</i>				
<i>Homo erectus</i>				
<i>Homo sapiens</i>				
<i>Homo neanderthalensis</i>				
Cro-Magnon				

Analysing

11 Analyse Figure 5.4.3 and list the following primates in correct order of evolution:

- Old World monkeys
- apes
- humans
- prosimians
- New World monkeys

12 Analyse the human family tree in Figure 5.4.6 and identify which species:

- a** represents us
- b** is on the human line of evolution
- c** is genetically most different to us
- d** is likely to have lived at the same time
- e** had the largest brain
- f** had the smallest brain

13 Analyse the skulls in Figure 5.4.13 and place them in the order of their likely evolution. **Explain** your order.

Evaluating

14 a Define the term bipedalism.

b Describe the advantages that bipedalism gives to an organism.

c Propose a name like bipedalism that could describe the movement of a dog.

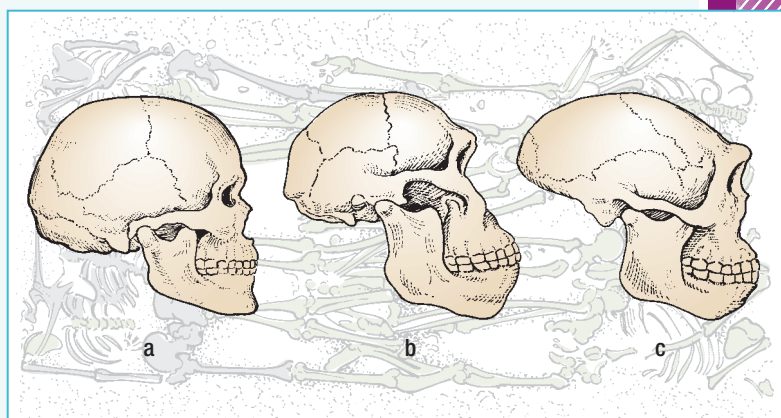



Fig 5.4.13

5.4 INVESTIGATING

Investigate your available resources (for example, textbooks, encyclopaedias, internet) to complete the following tasks.

- 1 Research the work of the Leakey family in searching for hominoid fossils in Africa. Write a biography to summarise their discoveries. 
- 2 Find why Lake Mungo in western NSW is so important and the role of geologist Jim Bowler.

3 Find out why anthropologists look particularly at the teeth and jaw and at skeletal modifications for bipedalism when they determine whether a fossil is ape or human.

- a** Research the structural differences and similarities between apes and humans.
- b** Work in small groups to construct various models of examples that demonstrate your research.

Prescribed focus area The history of science

Theories in science

Science is never definite and is always evolving. New discoveries are constantly being made that either confirm earlier ideas or lead to changes or rejection of them. Theories in science are based on the evidence available to scientists. As that evidence changes, the theories often change too.

Sometimes a theory is rejected outright and replaced with a new one. For example, an early theory of the solar system had the Earth at its centre. This is usually known as the **geocentric model**. The invention of

telescopes allowed astronomers to make detailed measurements of the movement of the planets. It soon became obvious that these movements did not match the geocentric model. The first response was to alter the model, but the changes needed (one called retrograde motion) were overly complex and illogical. Meanwhile, an alternative theory explained the movements without resorting to complex exceptions. This theory was called the **heliocentric model** and had the Sun as its centre. The theory was simple, logical and matched every piece of data ever collected about the solar system. It is now accepted as the only theory that explains the solar system.

Gravity is a theory, as is the **Big Bang**, that explains the origin of the universe and the nuclear atom which explains the inner structure of matter. These theories have evolved as new evidence is found, each theory being 'tweaked' slightly to explain the new evidence. All three theories are simple and logical and all three are accepted as the best explanations of the evidence obtained so far.

Global warming caused by the enhanced greenhouse effect is a relatively new theory that is now accepted as reality by most scientists. As more evidence becomes available, the theory is also gaining more support from politicians and their voters.

Evolution of the theory of evolution

Evolution is a theory just like the heliocentric solar system, the Big Bang, gravity and atoms. The theory of evolution is regarded as one of the most important theories in science and it too has changed as new evidence has become available. Most scientists now agree that evolution through the mechanism of natural selection is the simplest and most logical way of describing the origin of all the different life forms on Earth. Other mechanisms for evolution have been proposed but have been dropped as new evidence has become available: only natural selection is able to explain the evidence available to date.

Although the idea that life forms can gradually change goes back to the ancient Greeks, modern theory of biological evolution has only been developed over the past 200 years. All scientific theories must have evidence to support them and there is plenty of evidence that supports the theory of evolution. However, despite the wealth of evidence supporting it, evolution still provokes strong disagreement and heated debate, particularly on religious grounds.



Fig 5.4.14 Gravity is a theory that explains why things fall, why the planets orbit around the Sun and moons orbit around their nearest planets.

Science Clip

Cut off their tails with a carving knife ...

Experiments have been conducted to test if acquired characteristics can be inherited. In one experiment, the tails of mice were removed. Their offspring were all born with tails. The experiment was repeated for 20 generations and all mice were born with tails. The acquired 'no-tail' characteristic was obviously not being inherited.

Early theories of evolution

Up until the late 1700s, most scientists believed that the different types of organisms and their characteristics had been fixed for all time. The French naturalist Georges Buffon (1707–1788) questioned this 'fixity of species', suggesting instead that species could change. Erasmus Darwin (1731–1802), grandfather of Charles Darwin, also suggested that one species could change to another, but he had no evidence to support his ideas.

Lamarck's theory

The French naturalist Jean Baptiste Lamarck (1744–1829) was the first to attempt to describe how a species could change and evolve. Lamarck was a student of Buffon and spent many years classifying plants and invertebrates. He thought that the similarities and differences between living things made sense only if species were evolving.

Lamarck believed that organisms adapted through their struggle to survive. In 1809 he suggested that:

- organs are improved when used repeatedly and weakened when not used. These changes are called **acquired characteristics**. (Working out at the gym develops the acquired characteristic of larger muscles. Playing music or computer games develops the acquired characteristic of improved hand-eye coordination)
- any characteristics acquired by the parents (whether improvements or weaknesses) are passed on to their offspring.

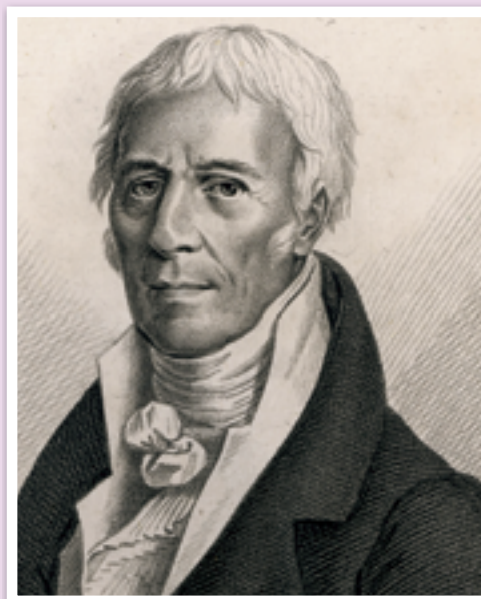
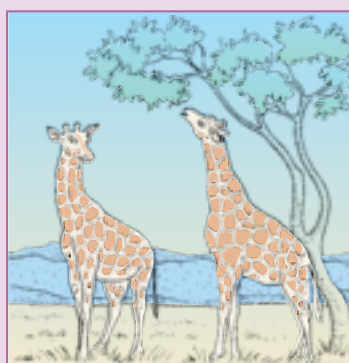
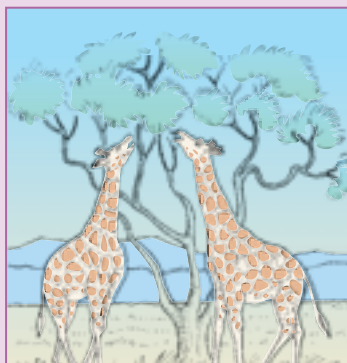

Fig 5.4.15 Jean Baptiste Lamarck's theory of evolution explained how animals might change over time. Genetics shows the theory to be fatally flawed.

Lamarck had no experimental evidence for his ideas and modern genetics shows his ideas to be wrong. Although many characteristics are inherited, characteristics acquired through an individual's life are not. If Lamarck's theory was true, then bodybuilder parents would give birth to children who would develop equally muscular bodies. Likewise, an amputee should give birth to babies lacking the limb the parent has lost.



Ancestral giraffes had short necks which stretched as they reached for food in the treetops.



The acquired characteristic of a longer neck was then inherited by their offspring. They would also have long necks.

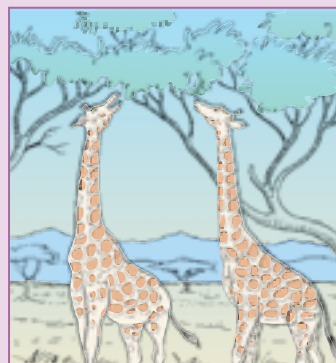

Each generation would stretch a little more and their offspring would inherit the new, longer neck. This happened until the modern giraffe evolved.

Fig 5.4.16 Lamarck's theory as shown here suggested that the necks of giraffes stretched as they reached for food in the trees. These acquired characteristics were then passed on to the next generation. This does not happen in reality.

Darwin's theory of natural selection

In 1831, Charles Darwin, aged 22, took a position as naturalist on the *HMS Beagle*, a ship commissioned to survey and chart the coast of South America. For the next five years, Darwin observed the geographical distribution of plants, animals, fossils and rocks in various parts of the world. He puzzled over the enormous variety and adaptations of the organisms he saw, and became convinced that different species of the same animal developed from a common ancestral type.

Science Clip

Darwin never lived in Darwin

Charles Darwin visited Australia aboard *HMS Beagle* in January 1836. Although his journal states that he was impressed by the climate, he found the countryside uninviting and couldn't think of any reason to move here! Despite this, the city of Darwin in the Northern Territory was named in his honour when the *Beagle* made another voyage to Australia in 1839. Although Darwin was not impressed with Australia, his great-great-great grandson, Chris was. He emigrated from England in 1986 and now lives in the Blue Mountains.

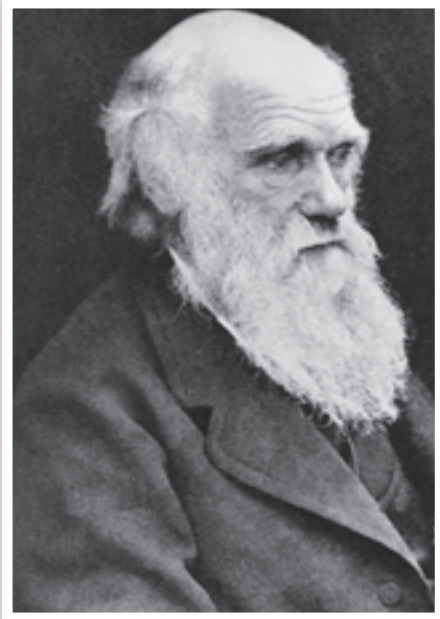

Fig 5.4.17 Charles Darwin (1809–1882) abandoned his studies in medicine and theology (religion) to become a naturalist.

Darwin's finches

About 1000 kilometres off the coast of the South American country of Ecuador are the Galapagos Islands. The islands are effectively isolated from one another by strong ocean currents, and there are no winds blowing from one island to another.

Much of the wildlife and plants found there (flowers, tortoises, iguanas and birds) differ in small but significant ways from island to island and to those on the mainland. Darwin was amazed by this diversity. He found, for example, 14 species of finches. All had similar colourings, calls, nests, eggs and courtship displays but they differed in their habitat, diet, body size and beak shape. Darwin proposed a process called **natural selection** which described how these 14 species could evolve from a common ancestor.

He suggested that a few finches had arrived at the islands at some time in the past. These finches showed natural variation in their beak shape. On one island, those with beaks of one shape were better able to feed on the cacti found there. Finches with other beak shapes found it difficult to survive. On other islands, other beak shapes gave some finches a feeding advantage. The birds most suited to their island survived to produce offspring, which inherited that beak shape.

Natural selection is sometimes called **survival of the fittest**. The 'fittest' were the birds that were able to feed and reach breeding age. The beak type that gave particular birds on a particular island an advantage was 'selected for'. Over many generations, the birds on different islands became sufficiently different from each other to be recognised as a different species.

Race to be first

Darwin spent the next 20 years collecting and sorting evidence for his natural selection theory of evolution. Meanwhile, another naturalist, Alfred Russel Wallace (1823–1913), was developing a similar theory. He realised that natural selection would 'improve' the species and '... the inferior would inevitably be killed

Science Clip

Obsessed with barnacles!

Although Darwin discovered birds on the Galapagos, he did not realise they were all finches until the famous naturalist John Gould pointed it out on Darwin's return. Although Darwin collected lots of specimens on his journeys, his journals were poorly kept. He failed to keep note of which islands different finches and tortoises came from and took many years to sort it all out. He did not publish his thoughts on evolution for more than 25 years. He was distracted though: he fathered 10 children and had an obsession with barnacles, spending eight years writing about them!

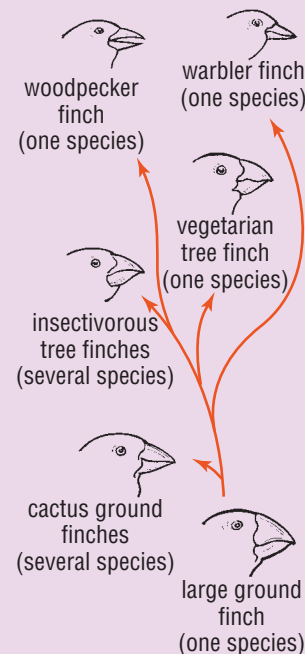
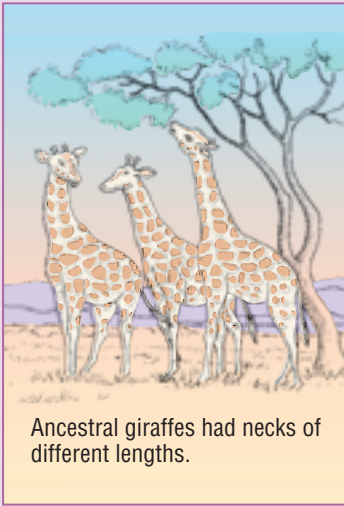

Fig 5.4.18 Darwin's finches: this evolutionary tree shows how different beaks might have been 'selected' for the food available on each particular island.

Science Clip

Survival of the fittest

Neither Darwin nor Wallace were present when their theory of evolution by natural selection was first presented to the Linnaean society on 1 July 1858. Darwin was at the funeral of his youngest son who had just died of scarlet fever and Wallace was still in Asia. Neither used the phrase 'survival of the fittest'. Although this term is usually attributed to Darwin, it was first stated by the philosopher Herbert Spencer in 1867, eight years after Darwin first published his theory.



Ancestral giraffes had necks of different lengths.

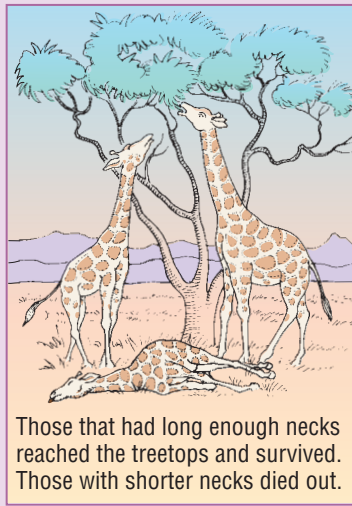

Those that had long enough necks reached the treetops and survived. Those with shorter necks died out.

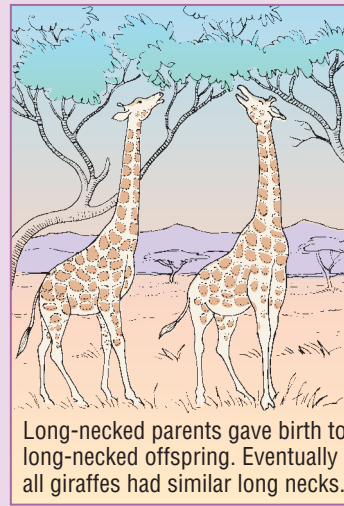

Long-necked parents gave birth to long-necked offspring. Eventually all giraffes had similar long necks.

Fig 5.4.19 The evolution of the giraffe's long neck according to Darwin

Science Clip

Fieldwork leads to evolutionary theory

Unlike Darwin, Wallace was raised in poverty and had no formal higher education. Instead, he gained his knowledge of biology through extensive fieldwork in the Amazon and East Indies.

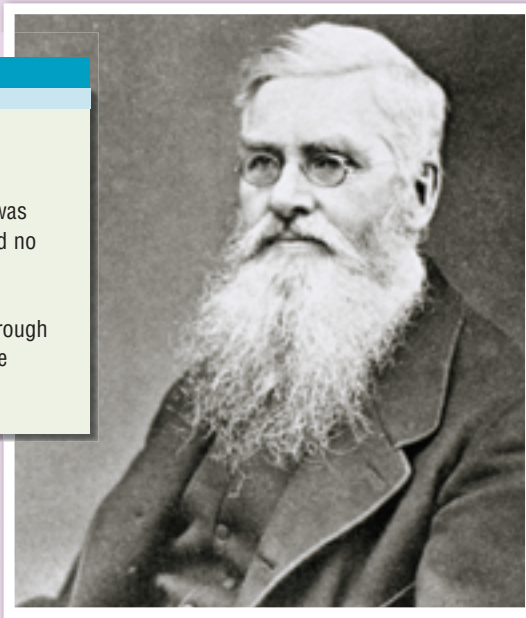

Fig 5.4.20 Alfred Russel Wallace

Science Clip

Shocked apes!

Despite much church opposition to his theory, Darwin was given a state funeral in Westminster Abbey in 1882. Religious opposition to Darwin's ideas has not disappeared. Even today, some American states require equal time to be given in science classes to the teaching of the biblical story of creation and to the theory of evolution.

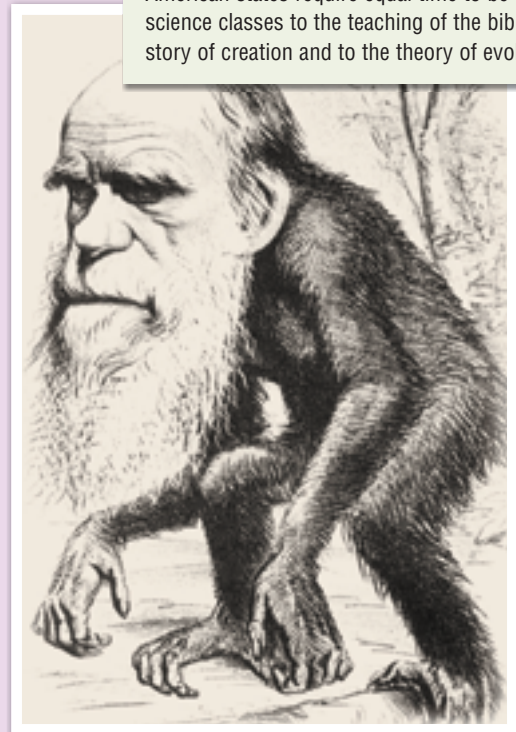

Fig 5.4.21 Although Darwin did not initially state that humans were descended from apes, the idea came naturally out of it. Many cartoons were soon printed mocking the idea. This is an 1871 cartoon showing Charles Darwin as an ape.

off and the superior would remain'. Wallace had reached a conclusion similar to Darwin's: that evolution occurs by natural selection. He published his ideas in 1855. His second paper on evolution was presented jointly with Darwin's in 1858.

Darwin completes his work

Darwin's major work, published in 1859, had the title *On the Origin of Species by Natural Selection or Preservation of Favoured Races in the Struggle for Life*. Although all 1250 copies of the first edition sold out within a day, religious leaders throughout England denounced his work as heresy and being against the word of God. Evolution by natural selection suggested that apes were the ancestors of man, contradicting the Bible which held that man was formed in the image of God.

Neo-Darwinism

Darwin was not the first to suggest evolution but he was the first to give it a scientific explanation. At that time there was no understanding of genetic inheritance and so Darwin had no way of explaining the variation in species that his theory depended on. Modern genetics is now able to explain how and why variation naturally occurs, how adaptations pass from one generation to another and why acquired characteristics cannot be passed on. This genetic explanation is sometimes called **neo-Darwinism**.

Alternatives to evolution

Although the theory of evolution has now been around for about 200 years, it continues to cause much argument. Different groups describe the origin of life in different ways.

Creation stories

Most societies have stories about the origin and diversity of life. Creation stories explain how the world and everything in it was made by supernatural means, by a god or gods. The ancient Greeks suggested the world grew out of Chaos, a dark mass where everything was hidden. From Chaos emerged a god and/or a goddess. They produced other gods and goddesses and then mortal men and women to populate the ancient world.

Some Australian Aboriginal people view the Earth at the beginning of time as a flat, featureless plain.



Fig 5.4.22 A rock painting showing Dreamtime figures

Later, in the Dreamtime, creatures partly resembling humans arose out of this plain. They suddenly disappeared, but left their mark as mountains, rivers, animals, plants and all the other features of Earth.

The Christian Bible and Jewish Torah tell how God created the Earth and all life on it in six days. There is also a story of the first man, Adam, being created from clay and the first woman, Eve, being created from his rib.

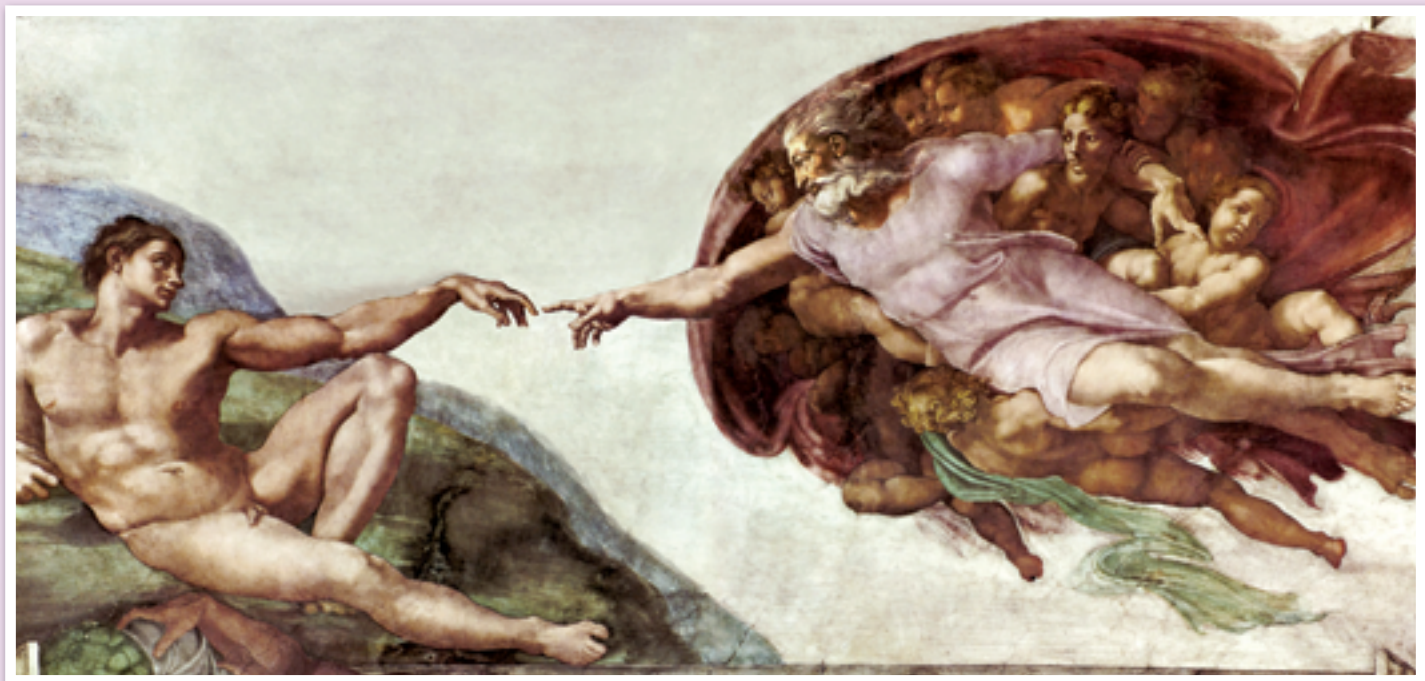

Fig 5.4.23 The fresco *The Creation of Adam* (1508–1512) by Michelangelo is part of the ceiling of the Sistine Chapel in the Vatican in Rome.

Intelligent design (ID)

Intelligent design is a relatively recent theory that suggests that an 'intelligent designer' was responsible for the complexity of the structure of organisms and cells. Although some supporters of this theory agree that natural selection can take place within a species, they believe natural selection would never be able to develop complex mechanisms such as the replication process of DNA or the whip-like tails (flagella) of some bacteria. The question then becomes: who or what is the intelligent designer?

Fact or fiction?

A major problem arises when considering these accounts of creation. Are they to be seen as factual? Some people believe the events happened exactly as stated. Other people interpret these accounts as stories with symbolic meaning, as teachings about the relationships between God or gods, the universe and humans. Others treat such accounts as nothing more than stories. The whole question of the origin of life is very tightly bound to religious belief.

Science Clip

A busy week in 3928 BCE

In 1642–1644, Dr John Lightfoot of Cambridge University in England wrote that the world was created on Sunday, 12 September 3928 BCE and that man was created on Friday, 17 September 3928 BCE at 9 am. In 1650, an Irish Archbishop, James Ussher, counted the generations of the Bible, adding them to modern history, and fixed the date of Biblical creation as Monday, 23 October 4004 BCE.

Science Clip

Descended from ET

There have been various suggestions that life on Earth originated in outer space. In his 1969 book *Chariots of the Gods*, Erik von Daniken proposed that aliens visited Earth and created human intelligence through deliberate genetic mutation. These visits were supposedly recorded and handed down through religion and myths, and in a few physical signs, such as the Nazca lines in Peru. In more recent times the famous astronomer Sir Fred Hoyle also proposed that life originated from outer space.

STUDENT ACTIVITIES

Remembering

- 1 Apart from evolution, **list** four other scientific theories.
- 2 **State** whether the following are true or false.
 - a Darwin was the first to think of the idea of evolution.
 - b Darwin's theory depended on organisms developing acquired characteristics.
 - c Darwin suggested that differences in finches were due to mutations.
 - d Darwin published his theory many years after his return on *HMS Beagle*.
- 3 For each of the following ideas, **name** the scientist who primarily developed it:
 - a evolution by inheritance of acquired characteristics
 - b adaptive radiation of the Galapagos Island finches
 - c evolution by natural selection
 - d organisms are guided through their struggle for existence by a creative force
- 4 **State** where the Galapagos Islands are located.
- 5 **Name** the naturalist who developed a similar theory to Darwin's at about the same time.
- 6 **State** what is meant by neo-Darwinism.

Understanding

- 7 **Outline** why the following can only ever be considered to be theories:
 - a the Big Bang theory
 - b the theory of the nuclear atom
 - c the theory of evolution
- 8 **Explain** how the giraffe's long neck evolved according to:
 - a Lamarck's theory of acquired characteristics
 - b Darwin's theory of natural selection
- 9 **Explain** why religious leaders objected to Darwin's theory when it was first published.
- 10 **Describe** what the phrase 'survival of the fittest' means when used in connection with Darwin's theory.
- 11 **Clarify** what is meant by a creationist view of the origin of life.
- 12 **Describe** two ways in which creation stories can be interpreted.

Applying

- 13 **Use** an example that shows Lamarck's theory is wrong.
- 14 **Use** Darwin's theory of natural selection to explain how 14 different species of finches developed on different islands in the Galapagos.



- 15 a Use** Lamarck's theory to account for the evolution of an elephant's trunk.
b Use Darwin's theory to account for it.

Evaluating

- 16** Darwin was unable to explain the natural variation that existed within a species.
a Explain how we account for this variation today.
b Propose reasons why Darwin was unable to explain it as we do.

Creating

- 17 Construct** a series of simple sketches to show how the long-legged, tree-grazing animal shown in Figure 5.5.24 might have evolved according to:
a Lamarck's theory
b Darwin's theory

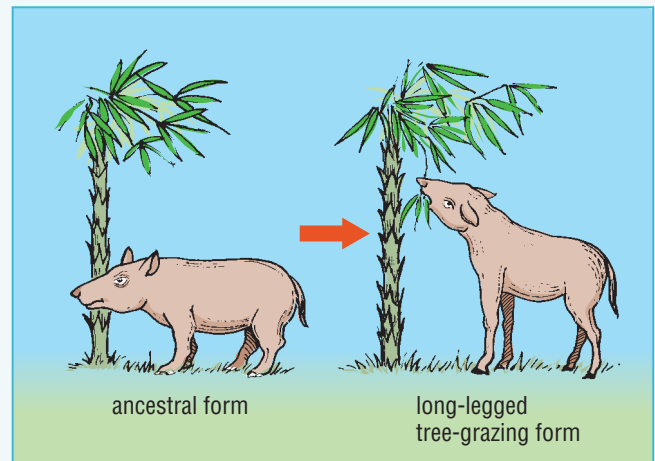

Fig 5.4.24

INVESTIGATING

Investigate your available resources (for example, textbooks, encyclopaedias, internet) to complete the following tasks.

- Trace the voyage of *HMS Beagle* from 1831 to 1836. Construct a page of Darwin's journal for one place that he visited. Describe the plants and animals he may have seen and how his observations might have influenced his ideas on natural selection and evolution.
- Find details about the following alternative theories and any evidence offered to support them:
 - creationism or intelligent design
 - the 'steady state' theory which proposes that species did not have a beginning at all but have always existed
 - that extraterrestrial beings 'settled' Earth or influenced the development of animals and humans on Earth.

Present your findings in one of the following ways: ①

- a debate between two theories
- a segment for a current affairs TV show
- a set of cards to be used in a debate in support of the theory you have researched
- a piece of art, drama, music or dance expressing the alternative theory you have investigated
- a class debate on whether alternative theories such as creationism or intelligent design should be taught in science classes.

Reviewing *Planet of the Apes*

Planet of the Apes is a film set in the future in which an astronaut is lost in deep space before crashing on a planet that is inhabited by apes and humans. Watch the most recent 2001 version of the movie and prepare a film review about it. In your review you must:

- give details about its length, leading actors, director, producer, studio and year of production
- describe the structure of the society on the planet
- describe the discrimination on the planet
- suggest why discrimination is fostered on the planet
- describe the information towards the end that explains what triggered the 'abnormal' evolution of the apes
- determine whether the evolution shown that advanced the apes' intelligence was Lamarckian (through acquired characteristics) or Darwinian (through natural selection)
- assess whether such extreme evolution of the apes is possible
- assess how accurate the science is in the film.

Present your review in one of the following ways: ①

- an interview with the director, a leading actor, chief of special effects or the scientist advising the director
- a segment for a TV program such as *ET*, *At the Movies* or *The Movie Show*
- a single-page spread for an entertainment magazine or for a movie guide.

CHAPTER REVIEW

Remembering

- 1 Natural variation can occur within species. **List** two ways in which this can happen.
- 2 **Recall** the process of natural selection by re-ordering the following statements.
 - i Rabbits with a gene for cold resistance survive, while other rabbits die.
 - ii Over several generations the number of rabbits with cold resistance increases.
 - iii Members of a rabbit population show variation in their resistance to cold.
 - iv Offspring of the surviving rabbits inherit the gene for cold resistance.
 - v The rabbits' habitat becomes colder due to a major climate change.

- 3 **Recall** the different types of evolution by matching each description with the correct term.

Term	Description
parallel evolution	results in structurally similar but unrelated organisms
convergent evolution	results in adaptive radiation
divergent evolution	produces structurally similar, closely related organisms that live in different places

- 4 **List** three possible reasons for the 'gaps' in the fossil record of life on Earth.
- 5 **List** two ancestors of *Homo sapiens*.
- 6 *Homo sapiens* have undergone much non-physical evolution. **State** a general term for this.

Understanding

- 7 Copy the following statements and **modify** each to make them true.
 - a Adaptations are inherited characteristics.
 - b Speciation usually involves reproductive isolation followed by geographic isolation of a population.
 - c DNA testing shows that the closest species to humans is the chimpanzee.
 - d The fossil record shows clearly that all organisms have evolved slowly and gradually.

e A bat's wing, a seal's flipper and a human arm are all homologous structures.

f Modern humans evolved from modern apes.

- 8 A whale has many adaptations that make it suited to its marine environment.

a **Define** the term *adaptation*.

b **List** some of the whale's adaptations.

- 9 Natural selection is the process whereby the environment selects favourable characteristics.

a **Outline** the meaning of the term *favourable characteristics*.

b **State** the main outcome of natural selection acting on a species.

- 10 Fossils can support the theory of evolution. **Describe** how they do this.

a **Clarify** what is meant by the term *homologous structures*.

b **Identify** the type of evolution that gives rise to homologous structures.

c **Clarify** what is meant by the term *analogous structures*.

d **Identify** the type of evolution that gives rise to analogous structures.

- 11 a **State** two similarities between an early human embryo and a fish embryo.

b **Explain** how these similarities may have come about.

- 12 Use the theory of evolution to **account** for the following observations.

a The scales on a bird's legs are similar to the scales on a reptile's body.

b The ocelot (a placental cat found in South America) and Australia's marsupial cat are not genetically similar, but have many similar features.

c Many plant-eating mammals have a large, useful appendix. Humans have a small, useless appendix.

- 13 **Describe** two changes which are thought to have occurred in the evolution of:

a *Australopithecus afarensis* to *Homo habilis*

b *Homo habilis* to *Homo erectus*

c Cro-Magnon to modern humans

Applying

- 14 Identify** three anatomical features that distinguish humans from primates.
- 15 Identify** which classification and times of appearance best match the common names of the different types of human.

Common name	Classification	Time of appearance (years ago)
Upright man	<i>Homo sapiens</i>	40 000
Cro-Magnon	<i>Homo habilis</i>	5 million
Handy man	<i>Homo erectus</i>	1.5 million
Neanderthal	<i>Australopithecus</i>	100 000
Lucy	<i>Homo sapiens</i>	2 million

Evaluating

- 16 a State** two ways in which a population may become geographically isolated.
- b Propose** ways in which a geographically isolated population would be likely to evolve differently from the remainder of the species.
- c Identify** two factors which might cause a population to become reproductively isolated from the remainder of the species.
- 17** Suppose the approximate 3600-million-year history of life on Earth was condensed into a 24-hour day. Select proposed times to match the events listed. Each hour would represent approximately 300 million years. **N**

Event	Time
Complex cells first appear	9.20 pm
Australopithicines first appear	2.00 pm
Dinosaurs become extinct	8.12 am
The Palaeozoic era begins	11.58 pm
Land organisms first appear	11.34 pm

 **Worksheet 5.4** Crossword 1

 **Worksheet 5.5** Crossword 2

 **Worksheet 5.6** Sci-words



Motion

6

Prescribed focus area

The applications and uses of science

Key outcomes

5.3, 5.6.2

- Average speed depends on the distance travelled and the time taken.
 - The acceleration of an object depends on the force applied and its mass.
 - Acceleration is a change in speed or direction and is the result of a net force.
 - Newton's Laws can be used to predict the motion of an object.
-
- Distance is how far an object has travelled.
 - Displacement is how far and in what direction the object is from the start.
 - Speed has no direction but velocity does.
 - Mathematical relationships can be used to calculate distance, speed, velocity, acceleration and force.
 - A force can cause an object to change its direction without any change in its speed.
 - A force applied so that it is always perpendicular to an object's motion causes it to turn in a circle.

context

Everything in the universe is in motion all the time. We are moving at 1300 km/h as the Earth spins on its axis and orbits the Sun. The Sun orbits the centre of our galaxy, the Milky Way. Ever since the Big

Bang, our galaxy has been moving away from all the other galaxies. On a much smaller scale, molecules are whizzing around in the air, and electrons are orbiting inside them. Understanding motion is one of the keys to understanding the world around us, and scientists have developed clear ways of describing motion.

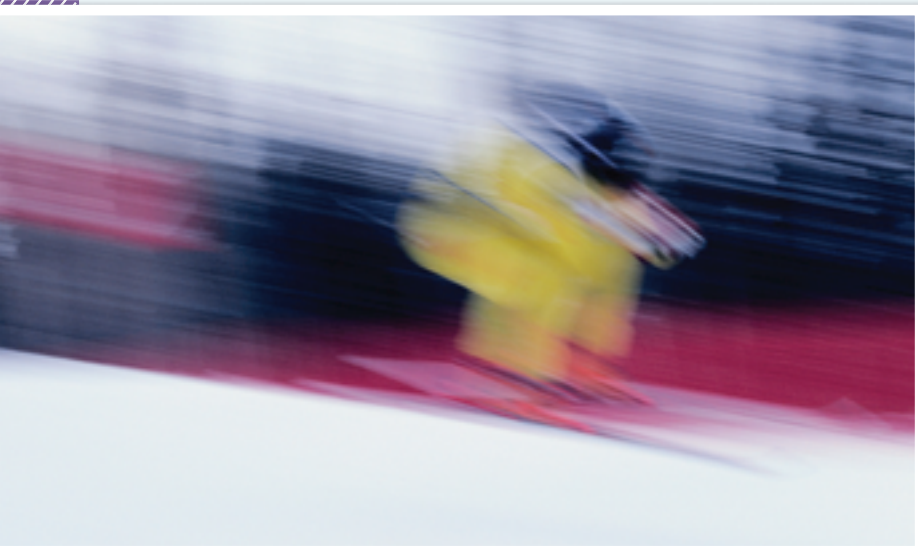

Fig 6.1.1 This skier is moving so fast that the camera cannot keep up. This makes the skier appear as a blur.



Most students move considerable distances every day: they travel to and from school, move from class to class, around their suburb or home town and within their home.

When they return home, they are back at the point they started out from that morning. Their displacement is zero.

Fig 6.1.2 Distance is how far you travel. Displacement is how far, and in which direction, you end up from where you started.

Distance and displacement



To describe a journey, most people would mention the distance travelled and the time it took. When physicists describe a journey, they use time much as other people would. However, they use two different terms to describe how far you have travelled:

- **distance**—this measures the actual distance travelled. Distance does not involve the direction in which you move at any time in your journey
- **displacement**—this measures how far you end up from where you started, and in which direction (up, left, north, towards the window etc.). Displacement is distance but with direction.

Distance and displacement are measured in the same units. Any length units can be used, but distance and displacement are usually converted into metres (unit symbol m) for calculations.

Science Fact File

Distance and displacement

Symbol in formulae: s – distance has no direction

- \bar{s} – displacement has direction
- Unit: metres
- Unit abbreviation: m

Time

- Symbol in formulae: t
- Unit: seconds
- Unit abbreviation: s

Speed and velocity

Speed

Car speed is measured continuously by the speedometer in kilometres per hour (km/h or kmh^{-1}). This is a measure of the car's **instantaneous speed** or its speed at any moment in its travels. **Speed** is the rate at which distance is covered—the amount of distance covered for each unit of time. Commonly used units of time are hours (unit symbol h) and seconds (s).

If the speed of a car is measured in kilometres per hour (km/h), then the car would travel that number of kilometres in one hour (assuming that the car kept moving at its current speed). This means that a car travelling a country freeway at 110 km/h will travel 110 km every hour it does so.

Another common unit used to measure speed is metres per second (m/s or ms^{-1}). Scientists usually convert all speeds and velocities into metres per second for calculations. To convert kilometres per hour into metres per seconds, divide by 3.6. To convert metres per second to kilometres per hour, multiply by 3.6:

$$\text{km/h} \begin{array}{c} \div 3.6 \\ \longleftrightarrow \\ \times 3.6 \end{array} \text{m/s}$$

You do not always have a speedo or radar gun with you to measure instantaneous speed. Some simple measurements, however, allow you to calculate **average speed**:

$$\text{average speed} = \frac{\text{distance traveled}}{\text{time taken}}$$

or $v = \frac{s}{t}$

Science Fact File

Symbols and units

Each of the physical quantities that are used to describe motion has both a symbol and a unit. For example, the symbol used for time is t but the unit in which time is measured is the second (s). Slightly confusingly, the symbol used for displacement is s and the unit for displacement is the metre (m). Italics are used for symbols but not for units, which makes it easier to distinguish between them. It's important to use the symbols and units correctly for clear scientific communication. We use a small arrow above the terms for quantities where direction is important, such as displacement (\vec{s}) and velocity (\vec{v}), since otherwise they use the same symbols as distance (s) and speed (v).



Fig 6.1.3 Police radar guns measure instantaneous speed.

Science Clip

That's slow!

The speed limit for cars in France was 13 km/h in 1893. Originally all cars in Great Britain were required to have a man walking in front of them with a red flag to alert horse riders! In 1896 the speed limit was raised to 20 km/h and, in 1904, to 33 km/h. The first Australian speeding ticket was given to Tasmanian George Innes, who was recklessly driving a car through Sydney at 13 km/h!

Science Fact File

Speed and velocity

- Symbol in formulae:
 v – speed has no direction
 \vec{v} – velocity has direction
- Unit: metres per second
- Unit abbreviation: m/s or ms^{-1}

If a school bus took half an hour to travel 10 kilometres to school, then its average speed would be:

$$v = \frac{10}{0.5} = 20 \text{ km/h}$$

This seems slow, but is an average of all the instantaneous speeds the bus did on its journey. The bus went faster than 20 km/h, but also stopped at traffic lights and bus stops. It also had to reduce its speed through school zones and shopping areas.



Fig 6.1.4 Since direction is important as well as speed, weather reports tell you the wind velocity, e.g. 30 knots south-east. A knot is a nautical mile per hour, about 1.85 km/h, so a 30-knot wind is blowing at about 56 km/h.



Fig 6.1.5 Multi-flash and composite high-speed photographs split a complex motion into a series of short time frames. The time-interval for each frame is so short that its average speed is close to the instantaneous speed for that frame.

Velocity

A weather report of 60 km/h wind gusts is useless to pilots, sailors, surfers and people fishing unless they also know the wind's direction. **Velocity** is speed in a given direction. Velocity has the same relationship to speed that displacement has to distance—they are measured in the same units, but add information about direction. Wind movement is usually stated as a velocity—for example, a 60 km/h wind coming from the south.

$$\text{average velocity} = \frac{\text{displacement}}{\text{time}}$$

Measuring motion

Averages are useful but tell little about what is actually happening at a particular moment. If the distance or time chosen for the average is small, however, average and instantaneous speeds become closer to each other. A runner might be timed at completing the 100 metre sprint in 12 seconds, but it would be better to measure the times taken to run past markers spaced at, for

example, 10 metres. The average speed of each section would show any changes that happened along the way. Spacings of one metre would be even better.

In the laboratory, the motion of an object can be measured in a number of ways depending on the equipment available.

- **Dataloggers**—there are a number of devices that will measure the distance, time, speed and direction of movement of an object, the data being transmitted by infra-red beam or cable to a computer for analysis by specialised software. The information obtained is accurate and can be easily manipulated into other forms such as graphs and values for acceleration and force.
- **Multi-flash photography**—a stroboscope is flashed onto the moving object and a camera or video on long exposure catches its image every time the strobe light flashes. Distances can be measured accurately off the image and time can be calculated from the flash rate of the strobe. The advantage of multi-flash photography is that it records different motions within the object, such as the movement of arms and legs.



- **High-speed composite photography**—many cameras will take a series of rapid images that can then be combined to form a single image. This method produces a similar image to that of multi-flash photography. If the rate is known, then speeds can easily be calculated from the image.
- **Ticker-timers**—an older device known as a ticker-timer breaks movement into a series of small intervals. It provides a way of accurately measuring distances travelled and times taken and provides the data from which average speeds can be calculated. A small electric hammer strikes a piece of carbon paper at the same frequency as its AC power supply, at a rate of 50 hertz (50 Hz) or 50 times a second. Motion is recorded as dots on a strip of paper that passes under the hammer. Unlike most dataloggers, ticker-timers can only measure straight-line motion in one direction.
- **Rulers and stopwatches**—since average speed only needs the distance travelled and the time taken, rulers, tape measures and stopwatches can provide data that will give you a rough overview of an object's motion.

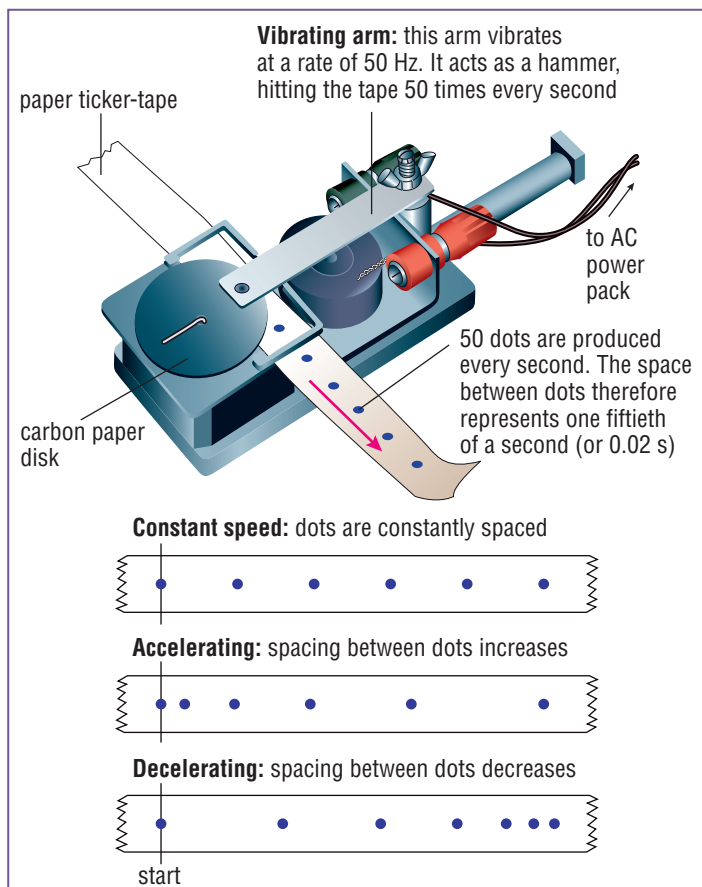

Fig 6.1.6 Although useful, the ticker-timer can only record motion in a straight line in one direction.

Graphing motion

Distance–time graphs

Graphs are very useful in representing the motion of an object travelling in a straight line.

Distance–time graphs show the total distance travelled by an object as time progresses. Time is always placed on the horizontal axis and distance on the vertical. Steep graphs indicate that the object is covering more distance and travelling faster than flatter graphs. A horizontal graph indicates no movement at all: the object is at rest or stationary. The slope or gradient of a distance–time graph gives us the object's speed.

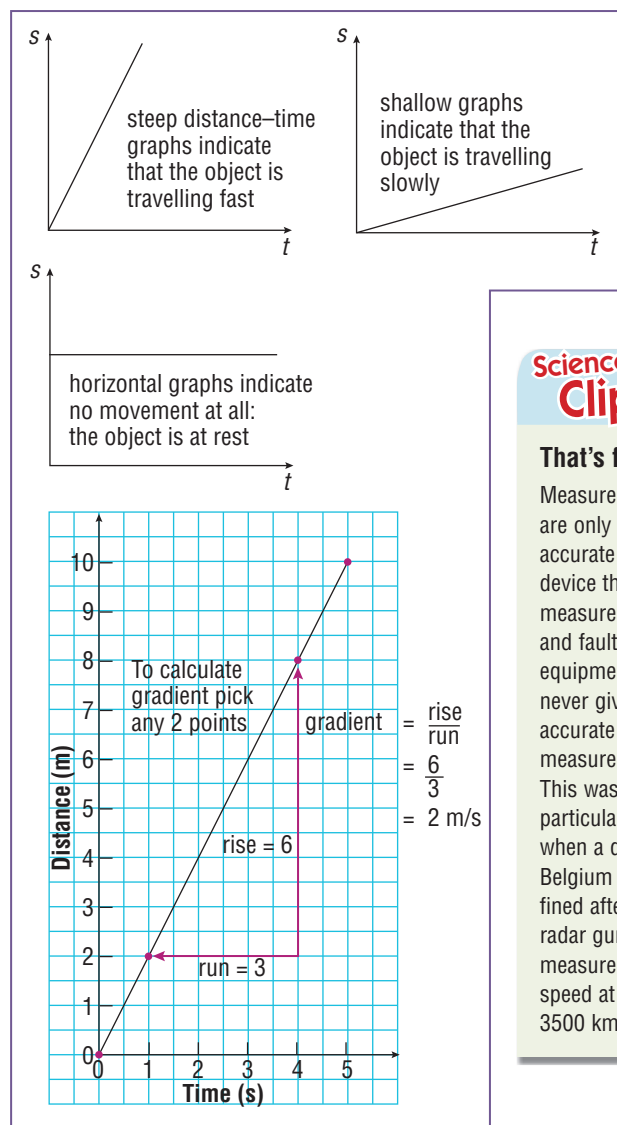

Fig 6.1.7 The slope or gradient of a distance–time graph gives the speed of an object. The steeper a distance–time graph, the faster the object is going.

Science Clip

That's fast!

Measurements are only as accurate as the device that measures them, and faulty equipment will never give accurate measurements. This was particularly true when a driver in Belgium was fined after a radar gun measured his speed at 3500 km/h!

Speed–time graphs

A graph of speed against time gives another picture of what is happening in the motion of an object. As before, time is placed on the horizontal axis. If the object is getting faster, the graph rises. If it is slowing, the graph falls. Constant speed gives a flat graph. The area under a speed–time graph gives the distance that the object has travelled up to that point. You can count the squares or use area-formulae to find the distance travelled.

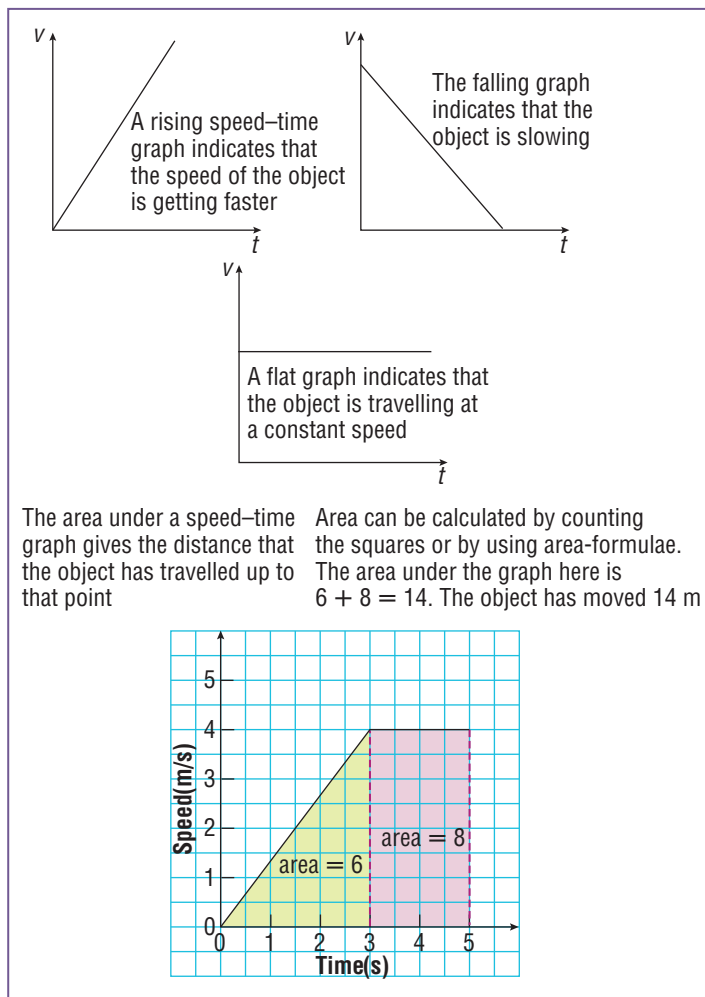

Fig 6.1.8 The total distance travelled is the area under a speed–time graph. The area here is $6 + 8 = 14$. The object has moved 14 metres.

Calculating distance

The average speed formula can be rearranged to give another useful formula:

$$\text{distance} = \text{speed} \times \text{time}$$

$$\text{or } s = vt$$

A car travelling at an average speed of 20 m/s for 5 seconds will have travelled a distance of:

$$s = 20 \times 5 = 100 \text{ m}$$

Humans do not respond immediately to emergencies, but take up to 1.5 seconds to react. This is their **reaction time**. This means that when in a car, a driver will not begin braking until well after they see an emergency. Meanwhile the car is travelling fast towards it.

To calculate the distance a car travels while the driver reacts, the speed must be converted into m/s to match the units used for time. Assume a car is being driven at 60 km/h (16.7 m/s) by a driver with a reaction time of 1.5 seconds. The distance the car travels before the driver brakes is then:

$$s = 16.7 \times 1.5 = 25.05 \text{ m}$$

This is equivalent to five to six car lengths.

A driver who is distracted (using a mobile phone, changing a radio station or who has consumed alcohol) may take as long as three seconds to react.

Worksheet 6.1 Distance–time graphs



Science Clip

Don't even think about stopping!

In about 700 BCE, King Sanherib of Assyria built a road from his capital, Nineveh, to nearby temples. It was so wide that it would have been equivalent to a modern freeway of 18 lanes! The king was justifiably proud of his road and didn't want it spoiled by chariots parked along it. Death was the penalty for doing so, with offenders being impaled on spikes!

6.1 QUESTIONS

Remembering

- State the symbol, metric units and their abbreviations for:
 - distance
 - displacement
 - time
 - speed
 - velocity
- A motion graph is horizontal. State what this indicates if the graph is a:
 - distance–time graph
 - speed–time graph
- State the formula used to calculate distance.
- List three factors that could be expected to influence reaction time.

Understanding

- Define the following terms:
 - instantaneous speed
 - displacement
 - wind velocity
- Outline how a:
 - distance–time graph can be used to determine speed
 - speed–time graph can be used to calculate total distance travelled
- Outline what a driver is doing during their reaction time in an emergency.
- A distance–time graph always increases and never drops down, while a displacement graph could drop down. Explain why.

Applying

- Use an example to **demonstrate** the difference between:
 - distance and displacement
 - speed and velocity
- Identify the formula used to calculate:
 - average speed
 - distance
 - average velocity
- For the motions shown in Figure 6.1.9, **calculate**:
 - the distance travelled
 - the displacement
 - the average speed for the whole trip
 - the average velocity for the trip **N**

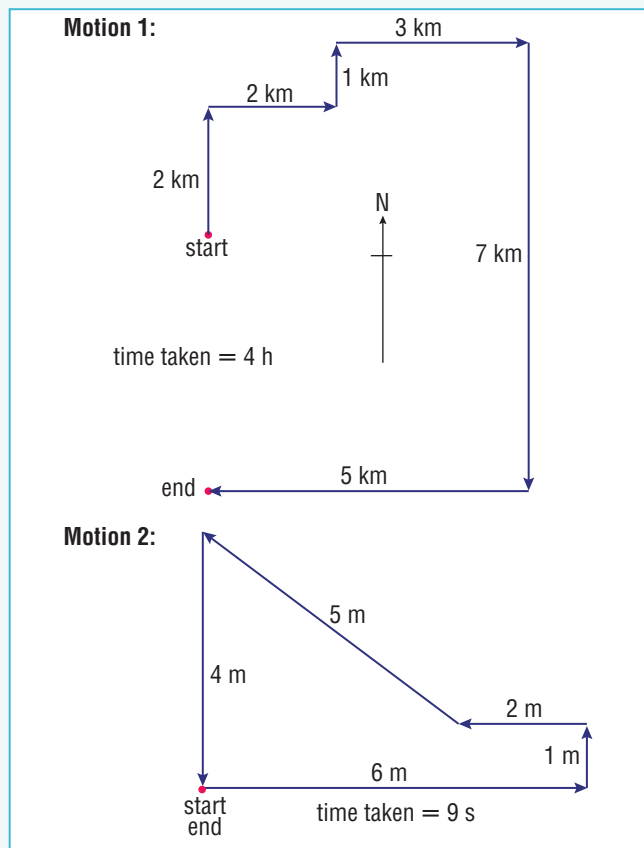

Fig 6.1.9

- Calculate the missing speeds in the table below (round answers to one decimal place). **N**

Speed	km/h	m/s
Athlete sprinting		11.7
Bushwalker	4.0	
Racehorse		19.0
Cheetah	100.0	
Greyhound		18.3
Cockroach	4.5	
Speed of sound		334
Antelope	88.0	

- Calculate the average speed of:
 - a car that travelled 990 km in 9 h
 - an ant that ran 24 cm in 2 s **N**
- Calculate the distance travelled by:
 - a jet in 6 h at 800 km/h
 - a sprinter running at 11.7 m/s in 8 s **N**

>>

15 Use the formula $t = s/v$ to **calculate** the time taken to travel:

- a** 75 m at 2.5 m/s
- b** 300 km at 60 km/h **N**

16 Scott leaves home for the 1.5 km walk to school at 8.15 and arrives at 8.45. Calculate his average speed in km/h. **N**

17 Thai tribe member Hoo Sateow died at the age of 77 in 2001, making it into the Guinness World Records for having the world's longest hair at 5.15 m. **N**

- a Calculate** the speed in mm/y at which his hair grew.
- b State** any assumptions made in the calculation.
- c Explain** whether the speed calculated is instantaneous or average.

18 Light travels at a speed of 300 000 km/s. **Calculate** how long it takes to travel:

- a** from the Sun to Earth, a distance of 149 600 000 km
- b** the 384 403 km distance between the Moon and Earth
- c** from Earth to Pluto, 5 750 400 000 km away **N**

19 Copy and complete the following table to **calculate** the distance a car would travel while the driver is reacting. **N**

Speed (km/h)	Speed (m/s)	Reaction time (s)	Reaction distance (m)
20		0.7	
50		0.6	
60		0.9	
100		0.5	
110		0.8	

20 Calculate the gradients of the graph in Figure 6.1.10 to find two different speeds. **N**

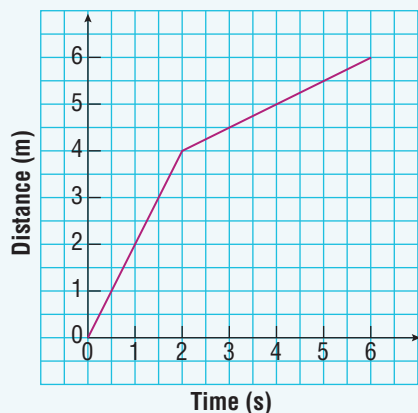

Fig 6.1.10

Analysing

21 Eight Zuni rockets launched a craft from Woomera, South Australia, in 2001, to gauge its impact in falling back to Earth. It reached a height of 5.9 km in 40 s. **N**

- a Construct** a scale for distance—see the photograph.
- b Calculate** the average speed of the craft.
- c Calculate** the distance the craft travelled before landing.
- d Calculate** the approximate displacement of the craft from launch to landing.
- e** The shape of the trajectory is a familiar one in mathematics. **State** its name. (Hint: turn the photo upside down.)

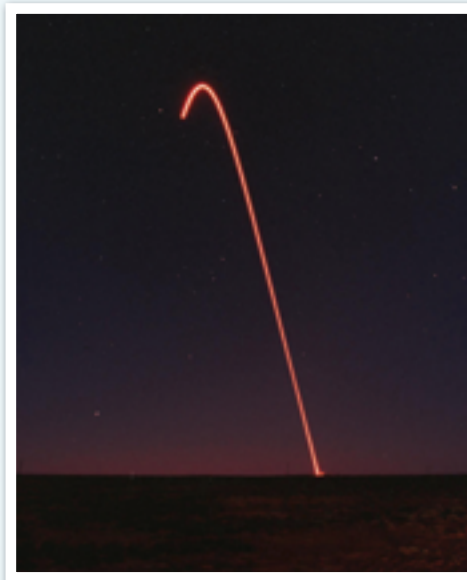
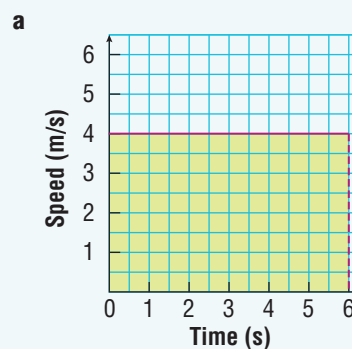

Fig 6.1.11

22 Calculate the area of the shaded parts of the v - t graphs in Figure 6.1.12 to find the distance travelled. **N**



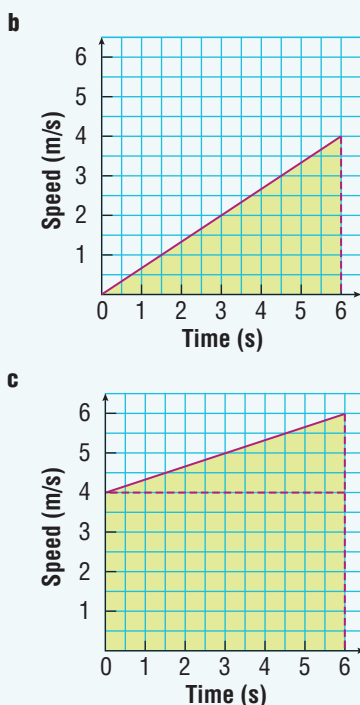

Fig 6.1.12

- 23** Sharnika graphed a trip she took at the weekend. She drew the displacement–time graph shown in Figure 6.1.13. **Calculate** the following:
- the distance Sharnika travelled in total
 - her displacement for the journey
 - the time she was away

- her speed for the first leg of the trip
- her return speed
- the times when she was stationary
- her average speed for the whole trip **N**

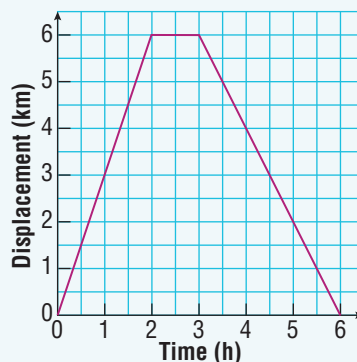

Fig 6.1.13

Evaluating

- 24 Propose** reasons why differing blood alcohol limits apply to different levels of drivers' licences.

Creating

- 25** Although speed is normally converted into m/s, it can be measured using any distance or time unit, such as km/h, miles per hour, centimetres per year, metres per minute. **Construct** a speedo that shows two scales—one in km/h and one other scale. **N**

6.1 INVESTIGATING

Investigate your available resources (for example, textbooks, encyclopaedias, internet) to complete the following tasks.

- Research how one of the following devices works:
 - a radar gun or speed camera for measuring speed
 - a fish finder for measuring depth and locating schools of fish.

Present your information as a booklet to explain your findings to someone who has just purchased the device.

- Research the meaning of 'sonic boom' and the speed at which it occurs. Use a diagram to demonstrate your information, including how a sonic boom is created.

- Research the times taken for the same race (e.g. the men's 100 m sprint) in each Olympics since 1896.

- Construct a graph showing the variation in time for the race through the past century. **N**
- Convert these times to speed, and construct a graph of speeds through the century. **N**
- Modern athletes can analyse their movement by viewing videos of their races. They can then correct faults in style that may affect their speed. The way athletes move and the equipment they use has changed over the past century to increase speed. Gather photos to show how the sprint sports of running, cycling and swimming have changed.

6.1 PRACTICAL ACTIVITIES

1 They've got the runs!



Aim

To collect data and construct a distance–time graph

Equipment

- stopwatches (one per person if possible)
- chalk or other markers
- access to a tape measure

Method

- 1 A student is to run a short distance (e.g. 50 metres). **Design** a way a group of students can collect as much data as they can about the run.

- 2 Gather all the data and display it in an appropriate table.
- 3 Repeat for another student's run.
- 4 Plot the results obtained for each run as a distance–time graph.

Questions

- 1 **Identify** where the student/s became faster or slower on the run. Describe what happened to the shape of the graph in these areas.
- 2 **Identify** where the speed would be reasonably constant.
- 3 Normally, experiments are repeated a number of times. However, only one set of measurements should be taken in this case. **Explain** why.
- 4 **Describe** what the graph would look like if the student/s was cycling and not running.

2 Ticker-timer experiment

Aim

To use a ticker-timer to measure the motion of an object

Equipment

- AC ticker-timer
- carbon paper circles and tape
- power pack
- scissors
- ruler
- graph paper
- paper glue

Method

- 1 Tear off about 1 m of tape and thread it through the timer.
- 2 Start the timer, then pull the tape through, changing its speed as it goes.
- 3 Repeat with new tape, until everyone in the group has their own tape.
- 4 Draw a line through the first clear dot, then every fifth dot after that. There should be five spaces per section. This represents a time of 0.1 seconds.
- 5 Number each section, then cut along the lines.
- 6 Paste the pieces in order onto paper to produce a speed–time graph.

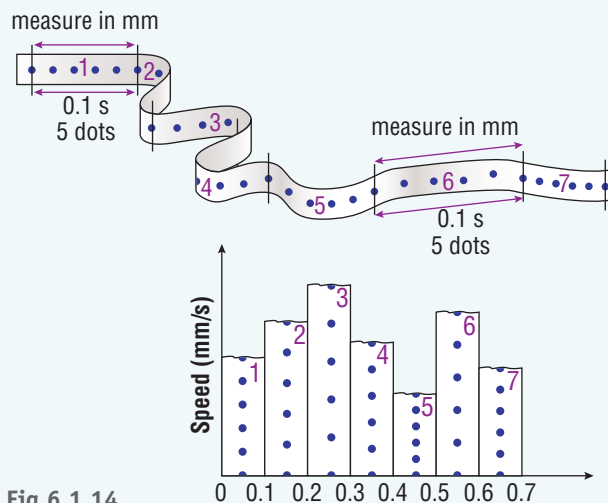

Fig 6.1.14

- 7 **Measure** the length of each section in millimetres and enter your results in a table like the one below. **N**

Section	Elapsed time (s)	Distance of each section (mm)	Total distance (mm)	Average speed (mm/s) Column 3 ÷ 0.1
0 to 5 dots	0.1			
5 to 10	0.2			
10 to 15	0.3			
15 to 20	0.4			
20 to 25	0.5			

- 8 Add axes to the cut-and-paste graph and use the values in the table to mark appropriate scales along each axis.
- 9 On graph paper, plot a distance–time graph for your hand’s motion.

Questions

- 1 **Explain** why it was important to number the sections before cutting.

- 2 **State** how many dots are produced by an AC ticker-timer in 1 second.
- 3 **State** how long it takes to produce:
 - a a new dot (this is equivalent to a single space)
 - b five new dots (equivalent to five spaces) **N**
- 4 **Explain** the disadvantages of a ticker-timer in measuring motion.

3 Measuring speed



Aim

To design and run experiments that will measure the speed of a moving object and the speed of sound

Equipment

- simple equipment such as tape measures and stopwatches or use datalogging equipment with appropriate sensors (light gates, ultrasonic sensors, microphones)

Method

- 1 **Design** your own experiment that will measure the speed of sound and the speed of a moving object.
- 2 Present your data and analysis as an experimental report that includes all the normal features such as aim, equipment, method, results, analysis and conclusion.

4 Chain reaction

Aim

To measure reaction time

Equipment

- stopwatch
- paper and pen to record results

Method

Part A

- 1 Gather into groups of 10 to 15 students.
- 2 Stand in a ring, with everyone facing outwards, about 50 cm apart.
- 3 One in the group (the starter) has a stopwatch. Another will record the group results.
- 4 The starter is to touch the shoulder of the neighbour to their right, starting the stopwatch when they do. When a shoulder is touched, the message is to be passed on.

Part A



Part B



Fig 6.1.15 Measuring group reaction times



5 Time how long it takes for the message to get back to the starter. Record the time taken and the number in the ring.

6 Repeat at least three times.

Part B

7 Repeat, but send the message to the left, using the left hand.

Part C

8 Send the message back to the right.

9 The starter can now touch either the left shoulder of their neighbour or they can lean behind them and touch their right shoulder.

10 If the left shoulder is touched, pass the message on to your neighbour by leaning behind and touching their right shoulder and vice versa.

11 Have a few practice runs before you record any times.

Questions

1 **Record** all results.

2 **Calculate** the average reaction time for each person, for parts A, B and C. **N**

3 **Discuss** whether there was any difference between sending the message to the right and sending it to the left.

4 Part C needed complex thinking. **Explain** what happened to reaction times when you needed to process information.

5 Driving reaction times

Aim

To measure your reaction time

Equipment

- 30 cm ruler
- access to a calculator
- access to the internet

Method

- 1 Form into groups of two.
- 2 Copy the table below into your workbooks.
- 3 Hold the 30 cm ruler vertically with the zero level with the top of your partner's hand.
- 4 Without warning, let go of the ruler. Your partner must catch it as quickly as possible.
- 5 Note the reading of the ruler (in centimetres) level with the top of your partner's open hand.
- 6 Have two trial runs and then record the data from the next three runs. It is physically impossible to have a reaction time less than 0.11 seconds, so disregard any drops that were less than 6 cm.

- 7 Repeat at least three times. Each student must have a turn as 'driver', but now distract the driver (touch their neck, tickle them etc.).

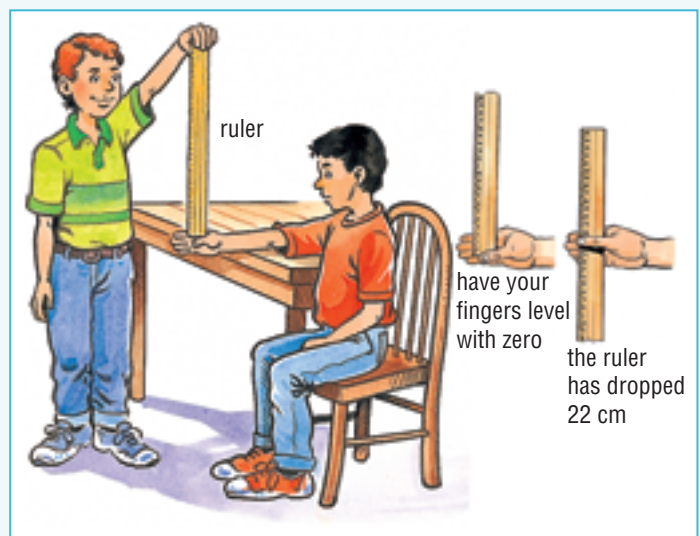

Fig 6.1.16

Without distractions			With distractions		
Ruler drops (cm)	Average drop (cm)	Average reaction time (s)	Ruler drops (cm)	Average ruler drop (cm)	Average reaction time (s)

- 8 Use this formula and your own data to calculate your reaction time:

$$t = \sqrt{\frac{d}{490}}$$

where t = reaction time (s)

and d = average ruler drop (cm)

Check that you are doing the calculation correctly.

If $d = 10$ cm the time should come out as 0.14 s. If not, find out what you are doing wrong with your calculator. **N**

- 9 Copy the table shown below into your workbook.
- 10 Use your reaction times to calculate the distance a car travels before braking at each speed.
- 11 In the yard or corridor pace out each reaction distance. Assume one large pace is about 1 metre.
- 12 Using the internet, use the words 'reflex tester' to find sites that allow you to measure your reaction time. Compare the reaction time obtained from that test with the time obtained in this experiment.

Questions

- 1 It was assumed here that the ruler dropped without any resistance. **Explain** whether this is true.
- 2 Your first drop was probably the worst. **Discuss** what this suggests about inexperience in an emergency.
- 3 **Explain** what distractions do to reaction times.
- 4 **List** some distractions a driver might logically encounter.
- 5 **Explain** what alcohol in the blood does to reaction time.
- 6 The Road Traffic Authority estimates that the reaction time of an average driver is between 0.5 s and 1 s. Times from this experiment are probably less. **Propose** reasons for the difference.

Speed of car		Without distractions		With distractions	
(km/h)	(m/s)	Reaction time (s)	Reaction distance (m) (Column 2 × Column 3)	Reaction time (s)	Reaction distance (m) (Column 2 × Column 5)
10					
30					
50					
60					
80					
100					

context

A sportscar or motorbike can change speed and direction more quickly than an ordinary car. Skate parks and roller

coasters also involve acceleration in different directions. Humans enjoy acceleration. The sudden slowing down that occurs in a collision is also a kind of acceleration, and can be much less enjoyable.



Fig 6.2.1 You are accelerating whenever you change speed or direction.

Acceleration

Imagine two cars taking off at traffic lights. Both reach 60 km/h, but their accelerations are not necessarily the same unless they took the same amount of time. If one took six seconds, while the other took 16 seconds, then it becomes perfectly obvious which one is accelerating the fastest. This can be written as:

$$\text{acceleration} = \frac{\text{change in velocity}}{\text{time taken for the change}}$$

$$\text{or } \bar{a} = \frac{(\bar{v} - \bar{u})}{t}$$

- \bar{v} is the final velocity
- \bar{u} is the initial or starting velocity
- t is the time taken for the change in speed to occur.

Acceleration is measured in velocity units per time unit. The most common unit for acceleration is metres per second per second, m/s^2 or ms^{-2} .

Science Fact File

Acceleration

- Symbol in formulae: \bar{a}
- Unit: metres per second squared
- Unit abbreviation: m/s^2 or ms^{-2}

This means that an object is changing its velocity (measured in metres per second) by a certain amount for each second it is travelling—metres per second, per second.

If an object slows, we say it is **decelerating**. Deceleration is also sometimes referred to as **negative acceleration**.

Calculating acceleration

If the velocity of a car changes from 0 to 60 km/h in six seconds, then its acceleration is:

$$a = \frac{(60 - 0)}{6} = 10$$

The units here would be speed units (km/h) per time unit (s) or km/h/s: the car gained an extra 10 km/h every second.

For an athlete, speed is more likely to be measured in m/s. For example, a runner is jogging along at 2 m/s but then slows their speed over the next five seconds until they are running at 1 m/s. Their acceleration would be:

$$a = \frac{(1-2)}{5} = \frac{-1}{5} = -0.2$$

The units here would be speed units (m/s) per time unit (s), that is, m/s^2 or ms^{-2} . The speed decreased by 0.2 m/s every second, changing by -0.2 m/s every second. The negative sign tells you that it is a deceleration.





Fig 6.2.2 Acceleration is what makes fun park rides such a thrill.



Fig 6.2.3 A composite high-speed photograph shows different stages in a motion. The spacing between each image gives some idea of speed. Increasing spacing shows acceleration.

Calculating speed

Let's say a rocket launches with an acceleration of 50 m/s^2 . It started at rest, but 50 m/s is added to its speed every second that passes.

If the rocket was already moving at, for example, 500 m/s , then the speeds would be those shown in the figure with another 500 m/s added to them.

This can be written as:

$$\text{final speed} = \text{starting speed} + \text{acceleration} \times \text{time taken}$$

$$\text{or } v = u + at$$

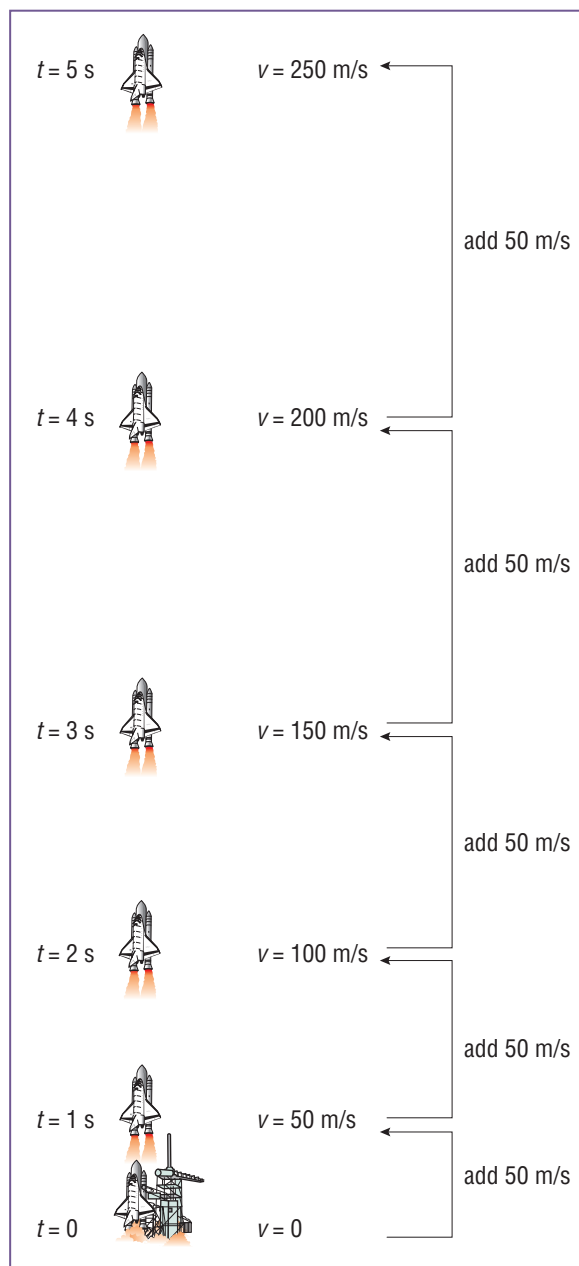

Fig 6.2.4 If acceleration is 50 m/s^2 , then 50 m/s is added every second.

Acceleration and graphs

High acceleration is a rapid increase in speed. The speed–time graph would be a steeper one than if you accelerated at a lesser rate; that is, the slope or gradient of a speed–time graph gives us the rate of acceleration.

Worksheet 6.2 Car performance data

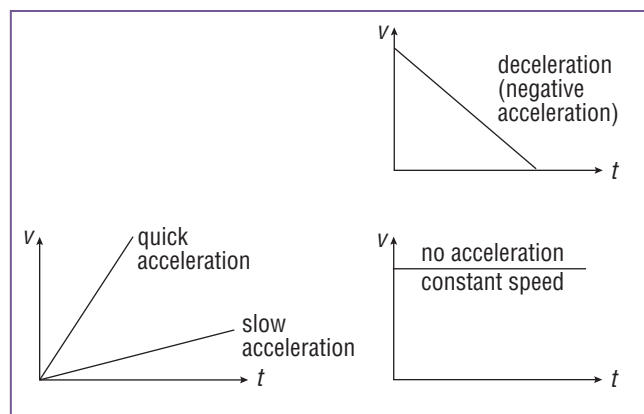
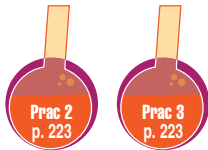

Fig 6.2.5 The gradient or slope of a speed–time graph is the same as acceleration.

6.2 QUESTIONS

Remembering

- State** the formula used to calculate acceleration.
- A runner has an acceleration of -0.2 m/s^2 . **Specify** what she is doing.
- State** the formula required to calculate the speed of an accelerating object.
- State** how much speed is gained every second if acceleration is 15 m/s^2 .

Understanding

- Describe** in words the formula $v = u + at$.
- Define** the terms:
 - acceleration
 - deceleration
- A car accelerates at 10 km/h/s . Write a sentence to **outline** what this means.
- Explain** why deceleration is always a negative number.

Applying

- Identify** the quantities and their symbols and units which are needed to calculate acceleration.
- Identify** the graph in Figure 6.2.6 that shows:
 - slow acceleration
 - rapid acceleration
 - no acceleration
 - deceleration

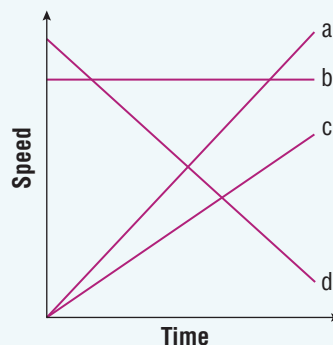

Fig 6.2.6

- Calculate** the speed of an object every second for the first 4 s if:
 - it starts at rest and accelerates at 5 m/s^2
 - it starts at a speed of 2.5 m/s instead of from rest **N**
- An object has zero acceleration. **Identify** the answer that best describes its behaviour.
 - The object is at rest.
 - The object is travelling at a constant speed.
 - The object is travelling at a constant velocity.
 - All of the above are possible.
- Copy** the following table and **calculate** the acceleration. **N**

Starting speed (m/s)	Final speed (m/s)	Time taken (s)	Acceleration (m/s^2)
0	50	10	
10	50	4	
50	30	5	
At rest	25	10	
60	Stationary	12	

- 14 Use the table below to **calculate** the final speed that these objects would have.

Starting speed (m/s)	Acceleration (m/s ²)	Time taken (s)	Final speed (m/s)
0	15	3	
20	8	5	
16	1	4	
30	-2	10	
15	-5	3	

- 15 A car accelerates from rest to 50 km/h in 5 s. **Calculate** the acceleration of the car in:

- a km/h/s
b m/s² **N**

- 16 **Calculate** the area and the gradient of each section of the $v-t$ graph in Figure 6.2.7 to find the distance travelled and the acceleration. **N**

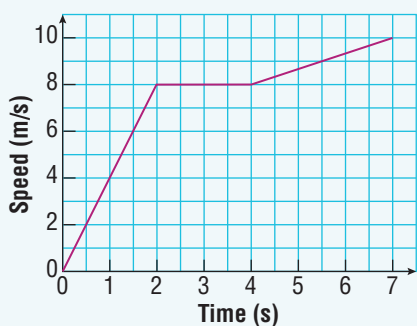

Fig 6.2.7

- 17 Linh, Beth and Brianna had a race. All accelerated smoothly from rest. Linh reached a speed of 24 km/h after 5 s, Beth reached 1.8 m/s after 2 s and Brianna took half a minute to reach 3.0 m/s.
- a Without changing units, **calculate** the accelerations of each. **N**
- b **Record** the measurements as m/s and s and **re-calculate** their accelerations.
- c **List** the three girls in ascending order of accelerations.
- d **Name** who broke away the quickest.

Analysing

- 18 a **Describe** what an even spacing of images in a composite high-speed photograph suggests about speed.
- b **Describe** what increasing spacing suggests.

- c **Analyse** Figure 6.2.3 to decide what is moving the fastest in the tennis serve.

- d **Analyse** whether the racquet is increasing or decreasing speed.

- e **State** what information would be needed to calculate speeds from this image.

- 19 The graph in Figure 6.2.8 shows data on distances that the 'average driver' needs to stop a car.

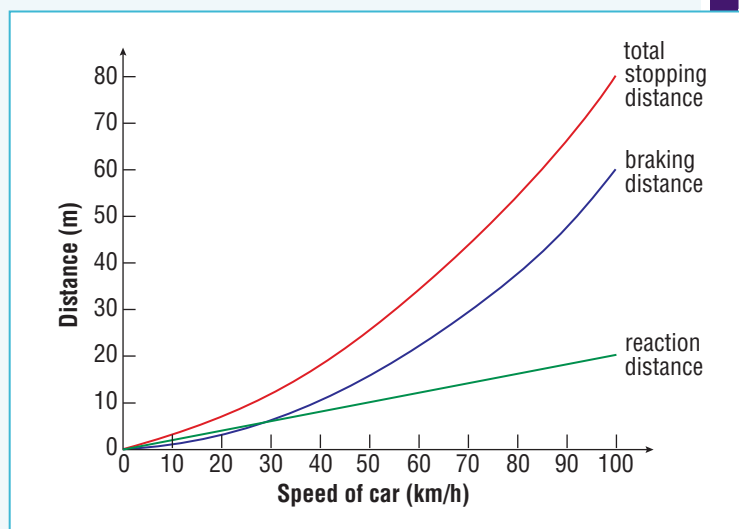

Fig 6.2.8

- a **Analyse** the graph to complete the missing information in the table below. **N**

Speed	Reaction distance (m)	Braking distance (m)	Stopping distance (m)
20			
50			
60			
80			
100			

- b In November 2003, New South Wales dropped the urban street speed limit from 60 km/h to 50 km/h. **Contrast** the stopping distances at each speed limit.

- c It is recommended that the distance between your car and the car in front should be equivalent to the reaction distance at that speed. **Evaluate** how many car lengths a driver travelling at 60 km/h and 100 km/h should leave in front of them. **N**

Evaluating

- 20** Which is the most appropriate unit for acceleration for a car?
Justify your answer.

Creating

- 21 Construct** a sketch speed–time graph for the girl in Figure 6.2.9 accelerating on a skateboard as she drops into the half-pipe.



Fig 6.2.9

6.2 INVESTIGATING

Investigate your available resources (for example, textbooks, encyclopaedias, internet) to complete the following tasks.

- 1** Research the factors that affect the braking distance of a car. Some of these factors are:
 - a** tyre design and tread
 - b** disc or drum brakes
 - c** ABS braking.

Research one of them and present your information as a print, radio or TV advertisement about the importance of this feature in car safety.

- 2** Find why cars sometimes skid when braking and what a driver should do to regain control. Explain how that action works.
- 3 a** Gather data from car magazines or the internet on at least two different cars.
- b** Plot speed–time graphs to demonstrate their performance from rest.
- 4 a** Estimate the acceleration and braking decelerations happening in the normal travels of your family car.
- b** Explain how you collected the data and show your calculations.

6.2 PRACTICAL ACTIVITIES

1 Braking distances

When cars brake in an emergency, the best deceleration on a dry road is about 90% g or -8.82 m/s^2 .

Go to Science Focus 4 Unit 6.6

Aim

To calculate the braking distances for a car travelling at various speeds

Equipment

- access to a calculator

Method

- 1** Copy the table below into your workbook.
- 2** Convert all the speeds from km/h into m/s.
- 3** Use the formula $d = \frac{v^2}{2b}$ to **calculate** the braking distance for a typical car. v stands for the speed of the car (in m/s) and b stands for the braking deceleration (in m/s^2). You will need to follow this order.
 - i** Put the speed (in m/s) into your calculator.
 - ii** Square it, then divide by 2 and divide again by the braking deceleration (b).
 - iii** The answer is the braking distance.
- 4** Get your reaction distances from Prac 5 in Unit 6.1.
- 5** Find the total stopping distance.

Car speed		Braking deceleration 90% g (m/s ²)	Braking distance (m)	Reaction distance (m) (from Prac 5 Unit 6.1)	Stopping distance (m) (Column 4 + Column 5)
(km/h)	(m/s)				
10		8.82			
30		8.82			
50		8.82			
60		8.82			
80		8.82			
100		8.82			
110		8.82			

6 In the yard or the corridor, pace out the stopping distances you found at each speed. Assume one pace roughly equals 1 m.

Questions

- a** **Predict** what would happen if brake performance was less.

b Test your prediction by halving it.
- Once the brakes are applied, the ability and state of the driver have little to do with the braking distance. **Assess** which of these factors affect reaction distance and which affect braking distance:

- alcohol and drugs in the blood
- bald tyres
- tiredness
- wet road
- noisy children in the back
- icy road
- poorly serviced brakes
- old car
- age of driver
- talking on a mobile phone

2 Acceleration and datalogging

Method

Design your own experiment in which you use datalogging equipment and sensors such as light gates and ultrasonic sensors to measure and plot the speeds and accelerations of a moving object.



3 Construct an accelerometer

Method

- Use Figure 6.2.10 to **design** your own accelerometer (a device that indicates acceleration).
- Get it moving along a bench, push it so that it travels at a constant speed or allow it to slide to a stop. Draw what the paperclip 'needle' does in each case.

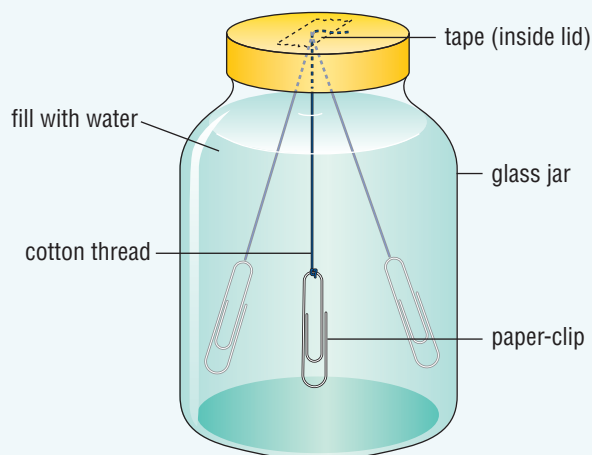

Fig 6.2.10 An effective acceleration indicator

context

Forces act on us every day, causing many different effects. In 1687, Isaac Newton asked how these forces act and what

interactions occur between them. He then formulated three laws to explain how objects move when a force acts on them. They are often referred to as **Newton's Laws of Motion**.



Fig 6.3.1 In this collision the rider has kept moving forward at the speed at which the bike was moving just before the accident. This is the effect of inertia. The rider will only stop when they hit something.

What is a force?

A **force** is a push, pull or twist that can cause an object to:

- increase its speed (accelerate)
- decrease its speed (decelerate)
- change its direction
- change its shape.

If any of these things happen, then a force caused it. It is possible, however, for a force to be acting without any of these things happening. This is because forces

Science Fact File

Types of forces

The force you apply is very obvious when you physically push or pull something. This is an obvious contact force. A summary of other forces that you will have met before is given below. Some will be discussed in this chapter.

Contact forces

- **Friction:** acts between any two surfaces that try to slide over one another; acts in the opposite direction to the movement or attempted movement.
- **Air resistance and drag:** friction of air (or liquid or other gases) as it travels across a moving object. Like friction, it acts in a direction opposite to the movement.
- **Buoyancy:** 'floating' force; acts upwards, opposing the weight force.
- **Surface tension:** tiny forces between particles on the surface of a liquid that form a 'skin' on the liquid.
- **Lift:** caused by air moving over a wing or airfoil; acts at 90° to the surface of the airfoil.
- **Thrust:** caused by gases or liquid being pushed out the rear of an engine, jet or rocket.

Non-contact forces

- **Weight:** caused by gravity. Attracts any two objects with mass to each other. We usually experience it as acting 'downwards', towards the centre of the planet we live on.
- **Electrostatic:** repulsion of like charges (+/+ or -/-) or attraction of unlike charges (+/-).
- **Magnetic:** repulsion of like poles (N/N or S/S) or attraction of unlike poles (N/S).

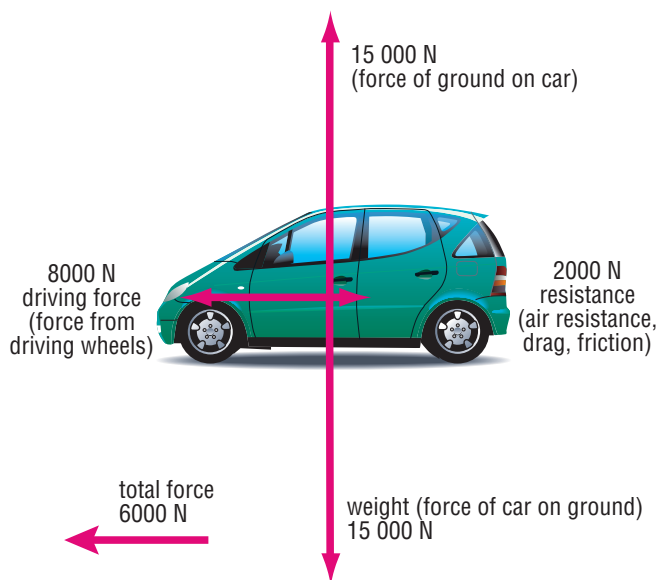

Fig 6.3.2 Forces often balance or cancel.



Fig 6.3.3 In a head-on collision, you will move forward as compared to the car around you. Crash test dummies have the same mass and basic movement as humans and are used to test what happens in collisions. This one is currently experiencing a head-on collision, its head rapidly moving forward as the car rapidly stops.

can balance each other out. If a pen is sitting on a desk, there is a downward force acting on it because of the Earth's gravitational field. If the desk was not there, this force would cause the pen to accelerate downward. That doesn't happen though because an upward force from the desk balances the downward force of gravity. There are two forces acting, but they are the same size and in opposite directions. They balance each other out and so the *overall* force on the pen is zero.

Newton's First Law

Newton's **First Law of Motion** explains what happens when an object is at rest or in constant motion, travelling at a constant speed without any change in direction.

No force and not moving

Place a pen on the desk. Watch what it is doing. Of course, it's not moving. This effect is called **inertia**. Sir Isaac Newton described it in his First Law. Newton's First Law states:

An object at rest will stay that way unless a force acts on it.

Therefore, a push or pull is required to get something moving. If you flick the pen with your finger you have applied a new force that is not balanced out by any other force, and the pen will start to move.

No force but still moving

Seatbelts in a car are there so that if the car stops suddenly, either using the brakes or in an accident, you stop too. Seatbelts distribute the forces across strong bony areas in our hips and shoulders. Without seatbelts, when a car stops in an accident the people in it keep moving forward as they were in the car before the accident and until they hit something. No new force has thrown them forward, they have just continued moving until a force acts on them to stop them. This is also inertia. Newton's First Law also states:

An object in motion will continue to move in the same direction at the same speed until a force acts on it.

If a car is travelling at 60 km/h, then so are its passengers. If the car is involved in an accident, it will stop very quickly (typically in about 0.1 to 0.2 of a second). However, passengers not wearing seatbelts will keep travelling at 60 km/h, until stopped by the windscreen or dash, or by a solid roadside object after being thrown from the car. The head tends to be the first part of the body struck. Seatbelts provide a restraining force and allow people to decelerate with the car. They also spread the stopping force across strong, bony areas of the chest and waist. Airbags also allow us to stop with the car.



Science Clip

Deadly dogs

In car accidents, an unrestrained family dog becomes a projectile and can potentially kill or injure anyone in the seating area. Most dogs range from 10 to 50 kg and will not be prepared for the accident when it happens, losing their balance and flying forward, with disastrous results.

Science Clip

Crash test humans

Crash test dummies were first developed by the US Air Force to determine the injuries that pilots would sustain if they ejected from aircraft in flight. Live humans were tested before the invention of the dummies, and Colonel John Stapp underwent 26 tests. In one, he sat in a rocket-powered open sled that accelerated to a speed of 1000 km/h in five seconds, but then was stopped in less than a second. Inertia kept his internal body parts and blood moving and he stated later that he felt as if his eyes would fly out of his skull.

Blood vessels in his eyes burst and they bled profusely for 10 minutes after the test. His lungs also collapsed, but he recovered quickly, proving that it was possible to survive such extreme forces.

Project BBQ

Crash test dummies have been used for over 30 years to develop safer cars. Before that, live but anaesthetised pigs were used in crash tests. A large pork barbecue often followed. Human corpses (cadavers) were also used in tests. Accelerometers and force meters were implanted in the cadavers to measure what was occurring. The results from these experiments led to the development of the modern crash test dummy, the Hybrid 3.

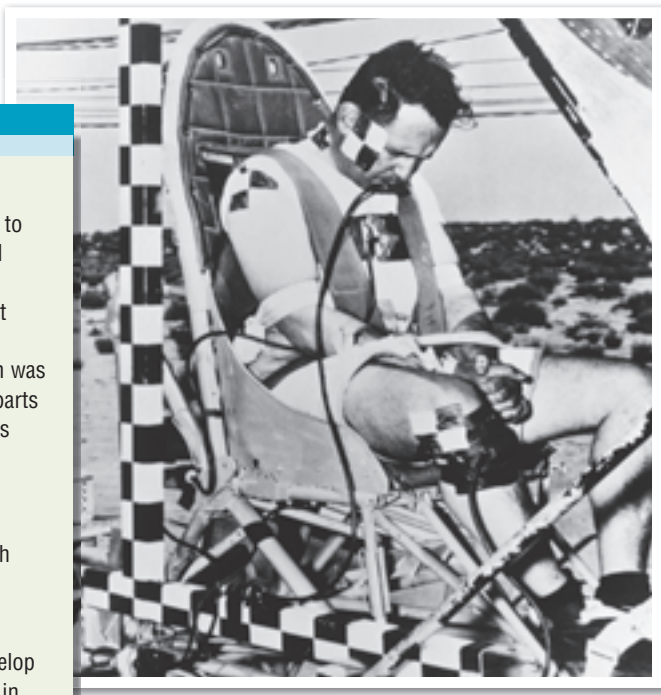

Fig 6.3.4 John Stapp feels forces on his body due to the inertia of each part as he accelerates. His body continues moving forward when the sled stops.

Feeling lighter, feeling heavier

Inertia explains why you sometimes feel lighter or heavier when in a rollercoaster or when travelling over speed bumps in a car. It also explains why you 'move sideways' when a car turns a corner. In all cases, you simply keep travelling in a straight line, just like you did before.

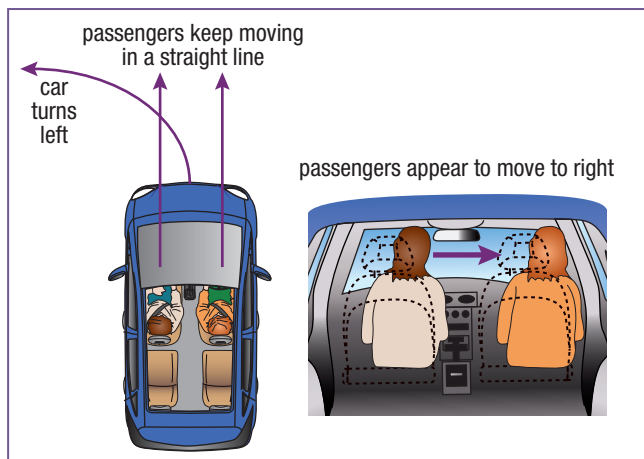

Fig 6.3.5 The occupants travel in a straight line, even though the car they are in turns. This 'throws' them sideways. Eventually the seat and seatbelt drag them around the corner with the car.

Science Clip

Motorbike airbags

Most modern cars have airbags, but it's a different challenge to provide this protection to motorcyclists who already have less protection than car drivers and passengers. One company produces airbag jackets for riders. The rider is connected to the bike by a short cable, and if the connection is broken, it means the rider has fallen away from the bike, and the jacket instantly inflates like an airbag to protect the rider.



Fig 6.3.6 Although inflatable airbags have been tested on motorbikes, inflatable jackets have been developed to protect riders in case of an accident.

Worksheet 6.3 Safety features

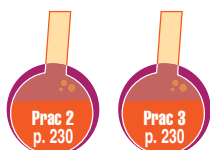

6.3 QUESTIONS

Remembering

- 1 **List** four possible outcomes when a force is applied to an object.
- 2 **Recall** the two parts of Newton's First Law.
- 3 **State** whether the following statements are true or false.
 - a An object needs a force to start moving.
 - b Passengers are thrown forward in a head-on collision.
 - c A typical accident takes one to two seconds.
 - d You have enough time in a collision to brace yourself to avoid injury.
 - e To keep something moving on Earth, you need to keep pushing.

Understanding

- 4 **Define** the following terms:
 - a force
 - b balanced forces
 - c inertia
- 5 **Predict** what will happen to the occupants of a car when it:
 - a turns left
 - b suddenly accelerates
 - c goes fast over a speed hump
 - d goes over a deep dip in the road
 - e collides head-on with a wall
 - f is parked, but is hit from behind by another car
 - g is parked, but is hit from the left by another car
- 6 **Outline** the features of a car that are designed to comfortably stop your forward inertia.
- 7 Use Newton's First Law to **predict** what will happen to acceleration when forces are balanced.
- 8 **a Explain** how a magician can pull a tablecloth out from under a table set with china.
 - b In reality, the china will probably shift slightly in the direction of the tablecloth. **Explain** why.
- 9 Rockets will keep moving in deep space and don't need engines to do so. **Account** for this fact.

- 10 Figure 6.3.7 shows three frames of a collision.
 - a **Predict** the type of collision that probably happened here.
 - b **Account** for what is happening in each diagram.
 - c Use this diagram to **explain** why modern cars are fitted with headrests.

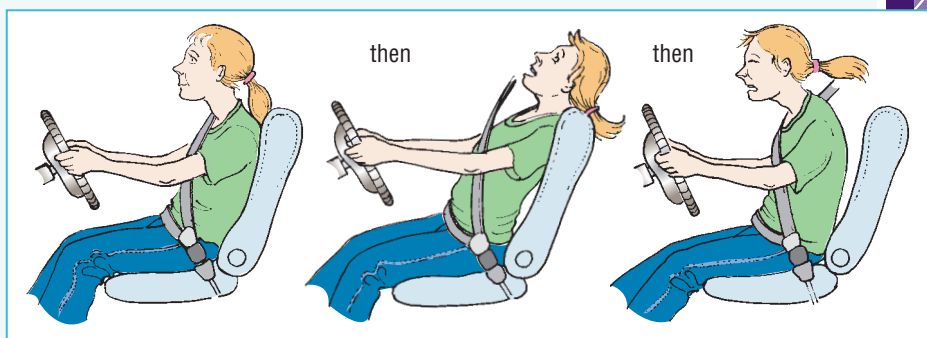

Fig 6.3.7

Applying

- 11 Even when a person is not wearing a seatbelt, their lower body is less likely to be influenced by inertia than their head. **Identify** which force(s) slow the lower body but are unable to act on the upper body and head.
- 12 A car on ice is almost impossible to stop or control.
 - a Use the concept of inertia to **explain** why.
 - b **Identify** the force required to gain control.

Analysing

- 13 **Classify** the following forces as either contact or non-contact forces:
 - a electrostatic
 - b lift
 - c thrust
 - d weight
 - e friction
 - f buoyancy
 - g air resistance
 - h magnetic
 - i drag

Evaluating

- 14 **Propose** reasons why truck cabins need to be rigid and able to withstand a heavy blow from the rear.
- 15 **Propose** why it is preferable to have the stopping force in a car applied to the chest and waist instead of the head.

- 16** Seatbelts leave bad bruising and can crack ribs in a car accident.
- a Explain** why they do this.
- b** A friend is arguing that this is a good reason not to wear seatbelts. **Propose** three reasons that would convince them to buckle up.
- 17** People sometimes hold a baby while travelling in a car, thinking that they will react and still hold onto the child in any accident. **Assess** whether these people are seriously risking the life of the baby.
- 18 Evaluate** whether passengers in the rear of a car are safe when not wearing seatbelts.
- 19 Assess** whether buses should be required to have seatbelts for all passengers and whether passengers should be allowed to stand.

Creating

- 20** In Figure 6.3.8 Johanna is swinging a bucket and let it go at point X. **Construct** a similar diagram and add an arrow at X to show in which direction the bucket will fly.

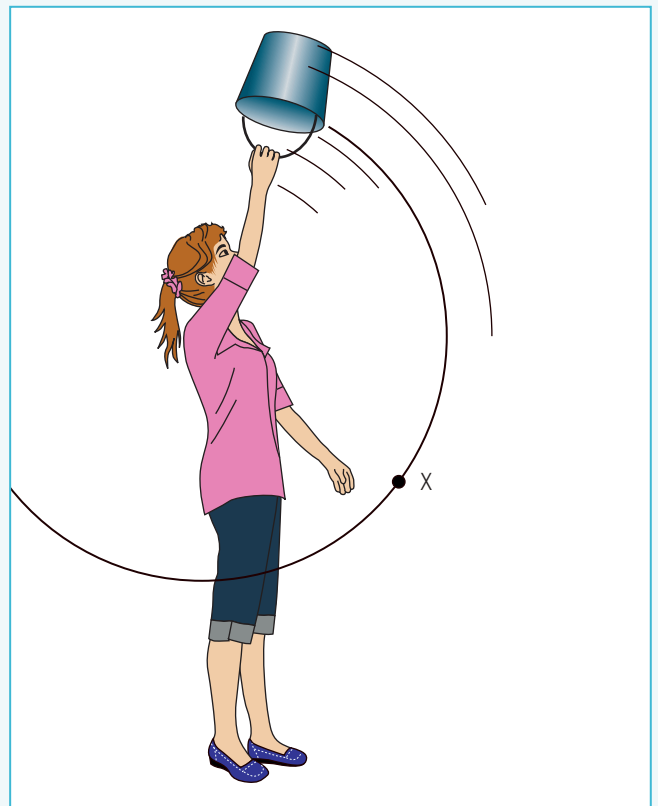

Fig 6.3.8

6.3 INVESTIGATING

Investigate your available resources (for example, textbooks, encyclopaedias, internet) to complete the following tasks.

- Research the use of airbags in cars. Present your information as a poster of a car that illustrates the use and features of airbags, including:
 - how an airbag is triggered and inflated
 - where airbags can be installed in a car
 - how much safer a car is with airbags than without
 - why most cars in Australia only have driver airbags.
- Research the development of crash test dummies and the current model, the Hybrid 3.
 - Imagine you had to sell the Hybrid 3 to car companies. Present your findings as a brochure on its benefits.

e-xploring

To **investigate** Newton's First Law, web destinations can be found on **Science Focus 4 Second Edition Student Lounge**. You will need to complete a tutorial including animations. Record a log of your progress, outlining any misconceptions you may have discovered and corrected.



6.3 PRACTICAL ACTIVITIES

1 Crash test dummies

Aim

To perform your own crash tests

Equipment

- dynamics trolley
- ramp
- ruler
- chalk
- a solid barrier such as a brick or wall
- plasticine or playdough
- talcum powder
- sticky tape

Method

- 1 Mould a small plasticine person. Lightly powder it so that it loses its stickiness.
- 2 Sit it on the dynamics trolley.

Part A

- 3 Set the ramp up on a shallow slope and let the trolley run down it and onto the floor. Carefully note what happens to the plasticine person.
- 4 Place a chalk mark every 20 cm up the ramp, and place a brick on the flat near the ramp's end.
- 5 Model a head-on collision by releasing the trolley from a 20 cm mark on the ramp (see Figure 6.3.9). Repeat from the rest of the marks. Note what happened to the plasticine

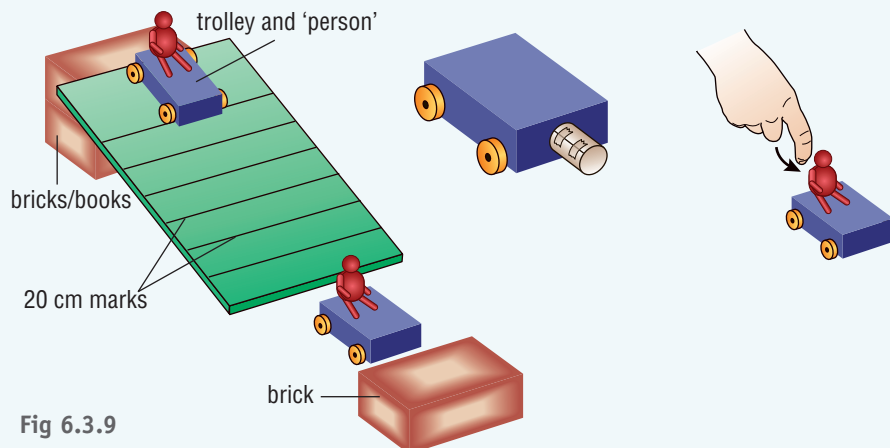

Fig 6.3.9

person, particularly to any parts of the body that moved a lot and any parts that moved little. Test which 20 cm mark you consider to be 'life threatening' to the plasticine driver.

Part B

- 6 Build a sticky-tape seatbelt for the driver and repeat. Are there any differences in the results? Which 20 cm mark is now the 'life-threatening' one?
- 7 Take the belt off, but this time add a 'crumple zone' to the front of the trolley. Once again, which 20 cm mark do you consider to be 'life-threatening'?

Part C

- 8 Place the trolley and its driver on a flat desk.
- 9 Model a rear-end collision by hitting or flicking the back of the trolley with your hand or a ruler. Once again, note which parts moved. Build a safety feature that would minimise injuries in this type of collision.

Questions

- 1 Your backside is probably the least affected part of your body in a car crash. **Explain** why inertia keeps heads, arms and legs moving but seems to be less effective on your backside.
- 2 **Predict** what would stop the forward movement in a car when no seatbelts are worn.
- 3 **Predict** the injuries that are likely to occur in a head-on collision while not wearing a seatbelt.
- 4 Modern cars are designed to crumple in an accident. **Propose** reasons why.
- 5 **Propose** reasons for the use of headrests in a car.

2 Inertial eggs

Aim

To determine whether an egg is raw or hard-boiled

Equipment

- 1 hard-boiled but unpeeled egg
- 1 fresh raw egg
- smooth desk
- pen or pencil

Method

- 1 Copy the following table into your workbook.

	Egg 1	Egg 2
Fast or slow spin?		
Began to spin again?		
Fresh or hard-boiled?		

- 2 Mark one egg '1' and the other '2' with a pen or pencil.
- 3 Place both eggs on a smooth desk and spin each equally hard.
- 4 Note which egg spun the fastest.
- 5 Spin each egg separately again. Place a finger on the egg to stop it briefly, but let go immediately. Note which egg remained stationary and which began to spin again.
- 6 Repeat step 5 to confirm your results.
- 7 Crack each egg over a sink. Which was hard-boiled and which was fresh?

Questions

- 1 If the shell of the fresh egg was spun, **predict** what its liquid insides would do.
- 2 **Predict** whether this would slow the spin of the shell.
- 3 In the experiment, once the whole egg was moving the shell was stopped. **Explain** what inertia suggests happened to the liquid inside the egg.
- 4 **Explain** why this would get the shell moving again when you let go.
- 5 **Discuss** why the hard-boiled egg spun faster and why it remained stopped when you let go.

3 The yolk's on you!



Your task

Use your knowledge of inertia to **design** your own safe container that will protect a fresh hen's egg from injury in a high-speed collision (vegans can use a light bulb).

The collision

Drop it from a first floor window or balcony onto concrete or bitumen.

The material

Use one piece of cardboard of roughly A3 dimensions, sufficient string, sticky tape, staples, glue or other fixings to hold it together.

You cannot use:

- tape etc. as reinforcing or padding
 - extra paper or cardboard for padding or parachutes.
- All fittings must be made from the original A3 sheet of cardboard.

context

When you ride a bike you have to apply a force to the pedals to get the wheels turning. The larger the force applied, the faster you accelerate. When you want to stop you have to apply a force, using the brakes to slow you down. The harder you squeeze the brakes, the faster you slow

or decelerate. A larger and heavier person on a bike will need to push harder than a small, light person, and will also need more braking force to stop. Turning a corner also involves force. This is Newton's Second Law.

Acceleration

Acceleration applies to any change in velocity. Velocity involves both speed and direction. This means that acceleration is happening whenever something changes its speed (for example, from 10 m/s to 20 m/s) or the direction in which it is travelling (for example, from north to east).



Fig 6.4.2 Acceleration depends on mass and the force applied.



Fig 6.4.1 Push and pull forces are very obvious in sports like NRL or ARU. Every change in speed, change in direction or change in shape is due to a force from other players, the ball or the ground.

All acceleration requires a force. The bigger the force, the greater the acceleration. Two people pushing a car will be more effective than just one person pushing it. However, if the car is a big one, the acceleration will be less: mass affects acceleration. **Mass** is the amount of matter in an object. It never changes unless you remove a bit from it or add more to it. A 2 kg mass stays as 2 kg regardless of where it is in the universe.

Science Fact File

Mass

- Symbol in formulae: m
- Unit: kilograms
- Unit abbreviation: kg

Science Fact File

Crumpling crashes

The force that you experience in an accident depends on the rate at which you come to a stop. If you decelerate more slowly, then the impact force is less. Modern cars are designed to extend the time you take to stop in a collision. Crumple zones slow the crash, and seatbelts and airbags allow you to decelerate with the car. Without this protection you will strike something hard. Deceleration and impact force will then be high.



Fig 6.4.3 Crumple zones increase the time over which an accident happens. They decrease deceleration and decrease the impact forces on the occupants. All this technology is useless, however, if seatbelts are not worn.

Newton's Second Law

Newton's Second Law states:

An object will accelerate if an unbalanced force is applied to it. Its acceleration will depend on the size of the force and the mass of the object.

$$\text{force} = \text{mass} \times \text{acceleration}$$

$$\text{or } \vec{F} = m\vec{a}$$

This formula can be rearranged to give:

$$m = \frac{\vec{F}}{\vec{a}} \text{ and } \vec{a} = \frac{\vec{F}}{m}$$

Worksheet 6.4 Calculating force



Science Clip

Spongy heads needed

Our head has very little padding and comes to a stop very quickly if it hits the road or kerb in a fall from a bike. Bike helmets extend the time during which your skull comes to a stop, thereby protecting your brain. The wearing of motorbike helmets has been compulsory since 1963 throughout Australia. In New South Wales, cyclists have been required by law to wear helmets since 1991. If only our heads were more spongy!

Science Fact File

Force

- Symbol in formulae: F (force needs direction)
- Unit: newtons
- Unit abbreviation: N

Fig 6.4.4 Forces don't always get you moving faster. A change in direction is acceleration too. This speed skater pushes sideways to generate a force perpendicular to motion. This doesn't speed her up but changes the skater's direction, making her travel in a circle.



\vec{F}
(points to centre of circle)

6.4 QUESTIONS

Remembering

- 1 **a State** Newton's Second Law of motion in words.
- b State** Newton's Second Law as a formula.

Understanding

- 2 **a Define** the term mass.
- b State** the metric unit mass is measured in.
- 3 **Describe** what happens to acceleration when the same force pushes larger and larger masses.
- 4 **Describe** what happens to the acceleration of an object if the force pushing it is increased.
- 5 Airbags are designed to inflate rapidly. **Explain** why they need to deflate as a person collapses into them.
- 6 Hammers are made from hardened steel because they need to impart huge forces on the nails they hit.
 - a Predict** whether the deceleration of the hammer on hitting a nail will be high or low.
 - b Explain** why a rubber hammer would provide less force and be less effective.

Applying

- 7 A car turns a corner without any change in speed. **Identify** the incorrect statement.
 - A It has no acceleration.
 - B Velocity has changed.
 - C Force was required to do the turn.
 - D Speed was constant.
- 8 Running is more comfortable and less likely to jar if you wear sport shoes with spongy soles. **Identify** the most likely reason.
 - A They have better grip.
 - B They reduce acceleration and impact force.
 - C They shorten impact time, making the force less.
 - D They stop the foot from rolling.
- 9 **Calculate** the force being applied if:
 - a a 5 kg box accelerates at 4.1 m/s^2
 - b a 1.3 tonne car accelerates at 2 m/s^2
 - c a 400 g ball accelerates at 4 m/s^2 **N**

Analysing

- 10 **Calculate** the acceleration caused by:
 - a a 40 N force applied to a 0.5 kg mass
 - b a 0.5 N force applied to a 50 kg mass **N**
- 11 A 35 N force causes a mass to accelerate at 7 m/s^2 . **Calculate** the mass. **N**
- 12 A 3.5 kg body accelerates from rest to 20 m/s in 5 s. **Calculate:**
 - a its acceleration
 - b the force required **N**
- 13 The brakes of a car can exert a stopping force of 3000 N. The car is 1.5 t. **Calculate** the following:
 - a the mass of the car in kg (note: $1 \text{ t} = 1000 \text{ kg}$)
 - b the deceleration of the car
 - c how long it would take to stop if it was travelling initially at 10 m/s **N**
- 14 **Compare** the maximum accelerations away from traffic lights of cars **y** and **z** shown in Figure 6.4.5 with the acceleration of the first car **x**. Use the following key to answer:

A: tripled	B: doubled	C: the same
D: halved	E: one-third of what it was	N

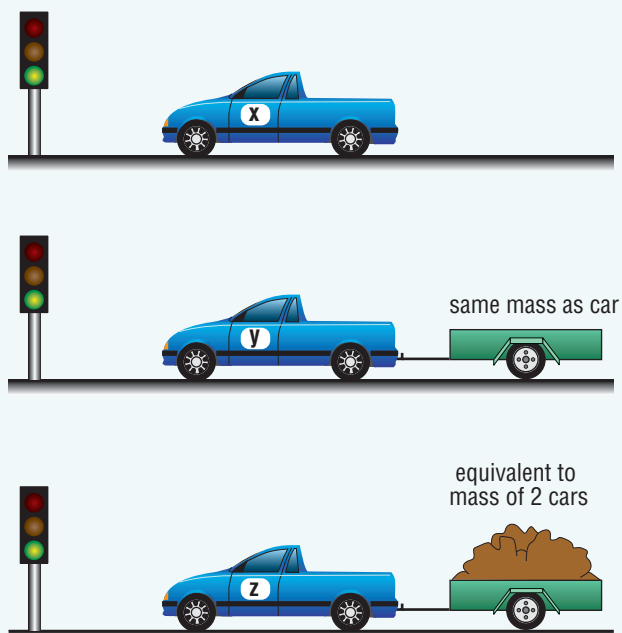

Fig 6.4.5



15 Calculate the overall force and acceleration on the masses shown in Figure 6.4.6: **N**

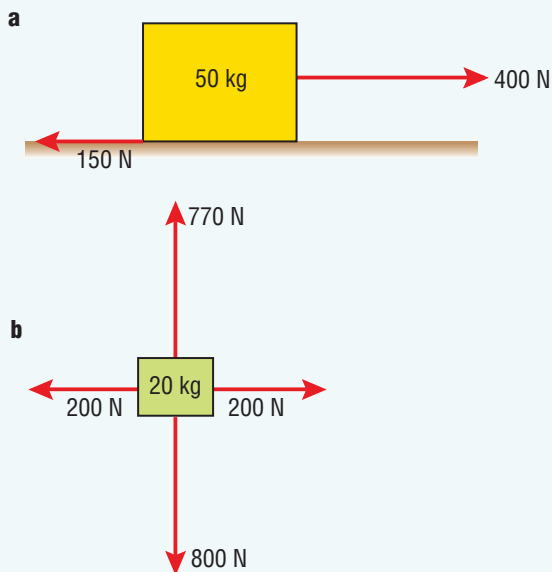

Fig 6.4.6

16 Complete the following table by **calculating** the missing values for acceleration or force. **N**

Force (N)	Mass (kg)	Acceleration (m/s ²)
	5.0	4.0
	6.1	2.0
12.0	4.0	
16.4	2.0	
9.3	3.1	

17 Sarah measured the acceleration of a trolley using the set-up shown in Figure 6.4.7 a. She found it to be 0.5 m/s^2 . She then replaced the 100 g with 200 g and then with 300 g. **Calculate** what she would expect the new accelerations to be in Figures 6.4.7 b and c. **N**

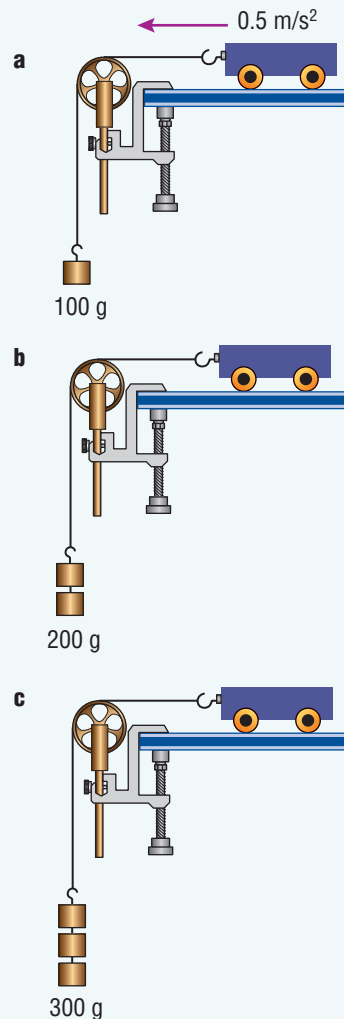

Fig 6.4.7

6.4 INVESTIGATING

Investigate your available resources (for example, textbooks, encyclopaedias, internet) to complete the following tasks.

- 1 Research the types of seatbelts installed in cars and their advantages. Present your information in the form of an advertisement designed to sell a model you think is effective.
- 2 Research bike helmets or sports shoe design and how they reduce deceleration and impact forces. Write an article for a consumer magazine explaining their special features.

e-xploring

To **investigate** Newton's Second Law, web destinations can be found on **Science Focus 4 Second Edition Student Lounge**. Complete the tutorial including questions. Record a log of your progress, outlining any misconceptions you may have discovered and corrected.



6.4 PRACTICAL ACTIVITY

1 $F = ma$

Aim

To investigate Newton's Second Law

Equipment

- dynamics trolley
- 50 g masses
- pulley and clamp
- block and clamp
- string or fishing line
- ruler
- access to electronic balance or beam balance
- either a ticker-timer, tape and carbon paper circles, or stopwatch, or appropriate light gates and datalogging equipment to measure acceleration

Method

- 1 Copy the following table into your workbook.

Hanging mass (g) = pulling 'force'	Mass on trolley (g)	Acceleration of trolley

- 2 Set up the apparatus as shown in Figure 6.4.8.

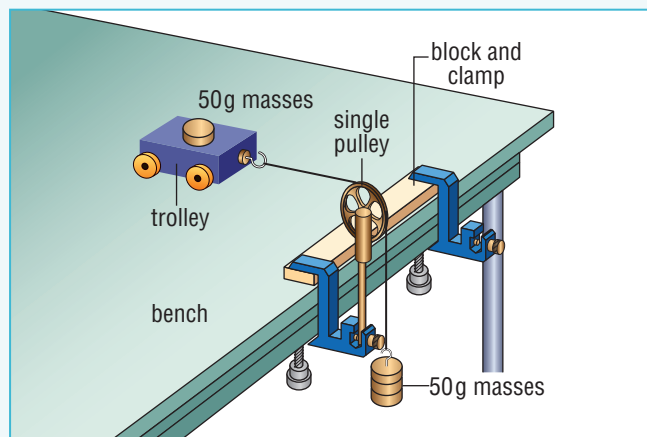

Fig 6.4.8 Measure the trolley's motion using one of the three methods described.



Part A: Changing trolley mass

- 3 Find the mass of the trolley and record it.
- 4 Measure the acceleration using one of the three methods described here.
- 5 Add a mass to the trolley and measure the new acceleration.
- 6 Repeat with at least three different masses.

Part B: Changing force

Hang 50 g on the line.

Method 1: Ticker-timer

- a Attach 1 m of ticker-tape to the back of the trolley.
- b Turn on and let the trolley pull the tape through.
- c Draw a line through every fifth dot and measure the distance between the lines in millimetres.
- d Calculate the speed (in mm/s) of each section by dividing the distance by 0.1. **N**
- e Plot a speed–time graph and then calculate the slope of the graph. This will be the acceleration in mm/s².
- f Change the mass and repeat.
- g Each member of the group should analyse one tape.

Method 2: Mathematical

- a Accurately measure out a 2 m track on the desk.
- b With the stopwatch, time the run. Repeat three times and find the average time taken.
- c Use the formula below to find the acceleration of the trolley in m/s². d is the distance of the run. **N**

$$a = \frac{2d}{t^2}$$

Method 3: Datalogging

- a Each equipment manufacturer will have instructions to determine the acceleration of a trolley.
- b Use appropriate sensors to find the acceleration.

Questions

- 1 Copy and complete:
 - a When the mass of the trolley increased, acceleration _____.
 - b When the mass and the force pulling the trolley along increased, acceleration _____.
- 2 Explain Newton's Second Law in your own words.
- 3 Deduce what effect mass had on the acceleration of the trolley.

context

A hose flicks about if it is turned on, its nozzle moving in a direction opposite to the water. The hose is pushing the water

out, but the water is also pushing the hose back in the opposite direction. A similar situation occurs whenever a weapon is fired. The weapon recoils (moves backwards) as the ammunition is fired forward.



Fig 6.5.1 You need to push back to move forward. This is an example of action–reaction at work.

Newton's Third Law

Newton explains the action–reaction phenomenon in his **Third Law**:

For every force there is a force of the same size acting in the opposite direction.

This is known as an **action–reaction** force pair. We sometimes call one force the action force and the other one the reaction force, but really they are both just forces. Which one we call the action force just depends on what we're most interested in.

When a ball is shot from a cannon, the forces on both the cannon and the ball are the same, but in different directions. The accelerations of the two objects are very different. The ball has a relatively low mass and so has a high acceleration and therefore velocity. Having more mass, the cannon is much less affected. This is in accordance with Newton's Second Law.



Action: the cannonball is pushed forwards. The ball is relatively light and so has a high acceleration and therefore velocity.

Reaction: the cannon recoils with the same force. Being heavier, the cannon is much less affected.

Fig 6.5.2 Weapons recoil due to Newton's Third Law. The forces on the cannon and the ball are the same, but in opposite directions.

Bats and balls

In sport, an action force is applied to a ball by a bat, racket or foot. When a golf ball is hit, the club pushes the ball and is pushed back by it. The ball is light and so its acceleration is high. The club is much heavier and the force is usually only enough to slow, not stop, the swing. It might also cause a 'shudder' through the handle. The reaction force would be felt even more if a golf club hit a brick!



Getting moving

For something to move forwards, it first needs to push backwards. This is most obvious when riding a bike or driving a car. When the driving wheel turns, it pushes the road backwards, sometimes spraying some sand, mud or water backwards. The road then pushes the bike or car forwards. This action–reaction pair depends on the traction or friction between the tyre and the road. On ice, the wheel will simply spin on the spot and there will be no forward movement. Walking and running also rely on action–reaction. Push the ground backwards and the ground pushes forwards.

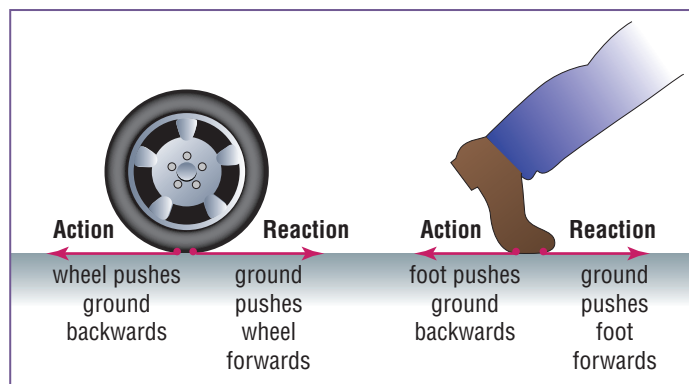

Fig 6.5.3 Action–reaction at work: push the ground backwards and it will push forwards.

... 3, 2, 1, lift-off!

Rocket engines are sometimes called reaction engines, as they use an action–reaction pair of forces to provide the thrust needed for launch. Rockets expel massive quantities of gases in one direction, and a force is exerted on these exhaust gases to cause them to accelerate. This is the action force in this pair. The reaction force of the gases on the rocket pushes the rocket in the opposite direction, usually upwards.

The exhaust gases are tiny particles but their effect is dramatic due to their high acceleration.

The exhaust is produced when fuel, called **propellant**, undergoes chemical combustion.

A liquid propellant engine uses two liquefied gases (for example, hydrogen and oxygen) which are combined in a combustion chamber. The resulting exhaust stream produces **thrust**—the force that propels the rocket. The thrust produced by the space shuttle at lift-off is 35 meganewtons (35 000 000 newtons), and accelerates the vehicle at three times the acceleration of gravity, or 3 g (i.e. about 30 m/s²).



Fig 6.5.4 Rockets and jets move forward because gases are expelled out the back.

Initially the thrust is not enough to overcome the weight of the rocket, so the rocket sits on the launchpad, making a lot of flames, but not going anywhere. When thrust equals weight the rocket begins to hover, and when thrust is larger than weight, it lifts off.

Rockets may also contain engines that use solid propellant. These engines are generally simpler, cheaper and safer than liquid fuel engines. The solid fuel is composed of several chemicals in proportions that allow it to burn quickly without exploding. Once started, a solid fuel engine cannot be stopped until all the fuel is used.

Jet engines work in a similar way to rocket engines: a mixture of air and fuel is compressed by a series of large fans, it then undergoes combustion that heats the air and causes it to expand. The exhaust gases and heated air are then pushed out of the rear of the engine with high acceleration. The backward force of the engine on the gases is the action force, and the jet is pushed forward by the reaction force of the gases on the engine.

Worksheet 6.5 The history of forces



Science Clip

Animal rockets

The purpleback flying squid (*Sthenoteuthis oualanieis*) squirts out jets of water in order to leap out of the sea to feed. It can then easily glide a distance of over 10 metres in the air.

Go to Science Focus 3 Unit 8.5

6.5 QUESTIONS

Remembering

- 1 State Newton's Third Law of Motion.

Understanding

- 2 Describe three examples that show Newton's Third Law of Motion in action.
- 3 Use Newton's Third Law to **outline** how a rocket achieves 'lift-off'.
- 4 Explain why a balloon shoots around the room when it is allowed to deflate.
- 5 a Firefighters often need to brace themselves or have extra help to hold a fire hose while it is on. Explain why.
b Predict what would happen if they did not have this help.
- 6 Explain why the acceleration of a rocket increases as its fuel is consumed.

Applying

- 7 Pat throws a netball.
 - a Identify the action force.
 - b Explain what the action force did in this situation.
 - c Identify the reaction force.
 - d Explain what the reaction force did in this situation.
- 8 For each of the following statements, identify the correct Newton's Law.
 - a The larger the force the bigger the change in motion.
 - b Any object at rest will stay that way unless pushed or pulled.
 - c For every action there is an equal and opposite reaction.
 - d Any object that is moving will keep moving at the same speed and in the same direction unless a force changes it.
- 9 The arrows in Figure 6.5.5 show gases being expelled out the back of the rockets. The longer the arrow, the more gases are being expelled. Copy or trace these 'rockets'. Identify any thrust forces produced and the direction the rocket would go or turn.

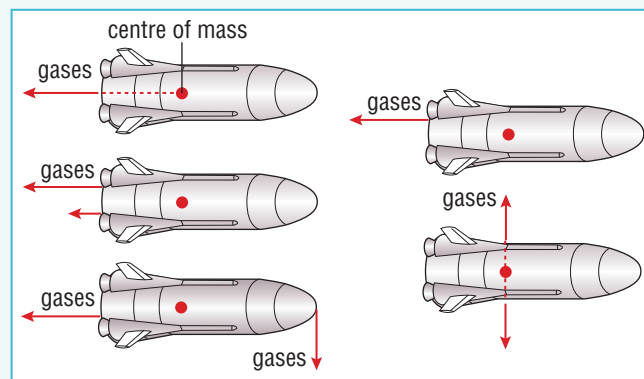

Fig 6.5.5

Evaluating

- 10 Michael is stranded on ice that is so slippery that he cannot walk. Propose a way in which he could get himself to nearby hard ground.
- 11 Rockets normally discard used fuel tanks soon after launch. Propose why.
- 12 Deduce which part of the launch these rockets are in:
 - a thrust = weight of rocket
 - b thrust > weight of rocket
 - c thrust < weight of rocket
 - d thrust = 0

Creating

- 13 Ben kicks a football. Construct a diagram to demonstrate the action–reaction pair of forces acting on the football:
 - a as it lies on the ground before being kicked
 - b as it is kicked, Ben's boot touching the ball
 - c as it flies through the air, having no more contact with the foot
- 14 Construct a diagram to show how a jet engine works using Newton's Third Law.

- 15** Copy the diagrams in Figure 6.5.6 and construct arrows to show all of the action/reaction force pairs in each.

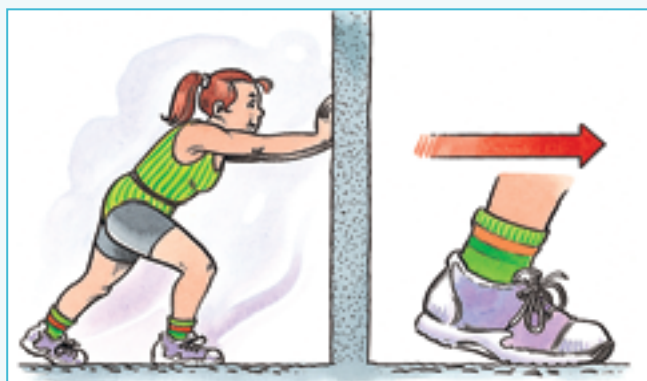

Fig 6.5.6

- 16** Using Figure 6.5.7 as a guide, take a whirly rocket for a spin. **Record** your observations and **deduce** whether Newton's Third Law is obeyed.

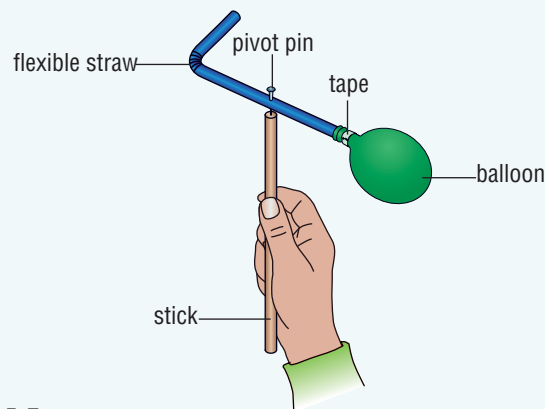



Fig 6.5.7

6.5 INVESTIGATING

Investigate your available resources (for example, textbooks, encyclopaedias, internet) to complete the following tasks.

- 1 a** Research how squids move, recording your findings using a diagram.
- b** List any other animals that propel themselves forward like a rocket.
- 2** Research the development of either the jet engine or the rocket. Use a timeline to summarise the major developments.
- 3** The V1 and V2 rockets were developed in Nazi Germany and were the first missile-based weapons used in warfare. Use a

diagram to demonstrate how these rockets use Newton's Third Law of Motion.

- 4** Write a brief journal article on the contribution of Werner Von Braun to the understanding of motion. 

e-xploring

To **investigate** Newton's Third Law, web destinations can be found on *Science Focus 4 Second Edition Student Lounge*. You will need to complete a tutorial including questions. Record a log of your progress, outlining any misconceptions you may have discovered and corrected.



6.5 PRACTICAL ACTIVITIES

1 Water rockets

Aim

To observe action–reaction forces in action

Equipment

- 1.25 L plastic softdrink bottle
- champagne cork (other corks or rubber stoppers may do, but the fit must be tight)
- sandpaper
- petroleum jelly
- safety glasses
- access to bike pump or electric pump
- access to power drill with fine drill bit
- access to hacksaw
- retort stand
- clamp and ring



Method

- 1 Cut the champagne cork with the hacksaw, shortening it so that it is a little shorter than the valve of the bike pump.
- 2 Sand the sides of the cork so that it fits neatly into the neck of the plastic bottle.
- 3 Drill a hole through the centre of the cork. Lightly smear the sides of the cork with petroleum jelly.
- 4 Fill the bottle to about one-third with water.
- 5 Push the valve of the pump through the cork and then secure the cork in the neck of the bottle.
- 6 Quickly place the bottle upside down in the ring.
- 7 Start pumping, standing well clear of the rocket.
- 8 Repeat, trying different amounts of water.
- 9 Repeat, trying different-sized plastic softdrink bottles.

Questions

- 1 **Identify** the action–reaction force pair in this situation.
- 2 **Identify** the ‘fuel’ for this rocket.
- 3 **List** the forces that slowed its ascent.

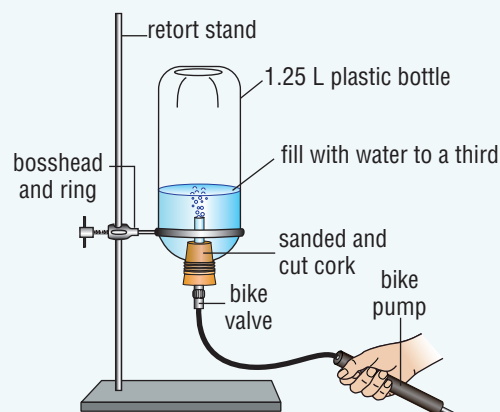

Fig 6.5.8

- 4 **Recommend** how these forces could be reduced.
- 5 More water did not necessarily produce increased height. **Discuss** why.
- 6 **Evaluate** the effect of different-sized plastic bottles on height.
- 7 Trigonometry can be used to find the height reached by the rocket. **Describe** how this can be done.



2 A two-stage rocket

Aim

To construct a two-stage rocket using balloons

Equipment

- plastic cup
- scissors
- 2 balloons (1 long, 1 round)
- tape

Method

- 1 Cut the bottom out of one of the paper cups.
- 2 Partly inflate the long balloon and pull it through the bottomless cup, taping the opening to the side of the cup as shown in Figure 6.5.9.
- 3 Place the round balloon inside the cup and blow it up so it wedges inside the cup. Hold the opening shut.
- 4 Remove the tape holding the long balloon on the side of the cup and release the end of the round balloon to launch your ‘rocket’.

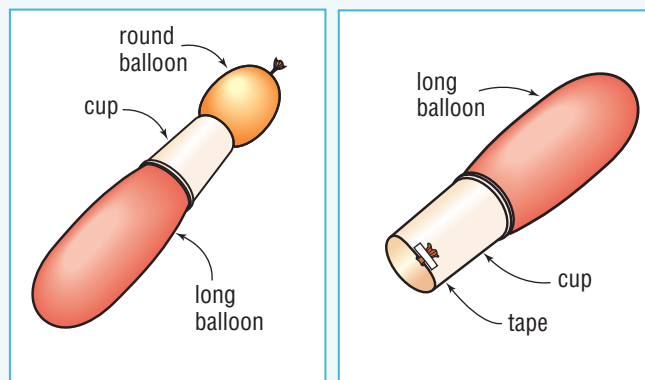

Fig 6.5.9

Questions

- 1 **Account** for the propulsion of the rocket.
- 2 **a Explain** how the rocket could be enlarged to include a third stage.
b Assess whether there would be a limit to how many stages you could attach.

context

Rock climbers appear to defy gravity. Climbers push down on handholds and footholds to advance up the rock. By maintaining a balanced position, climbers can remain stable regardless of their weight. An upward frictional force on the hands and

shoes opposes a downward force due to gravity and allows the climbers to move upwards. Gravity is that unseen quantity that is always trying to pull objects toward the centre of the Earth.

Gravity

Gravity is a force that exists everywhere in the universe. It attracts any object that has mass—and all objects do—to every other object that has mass. The force of attraction depends on the size of the two masses and the distance between them. Gravitational forces are quite weak for small masses—that’s why you don’t find yourself being suddenly drawn towards other people or the wall or ceiling as you move down a corridor. For large masses like planets and stars, the force is very strong. The main gravitational force you experience is due to the huge mass of the Earth and the fact that we are close to the Earth. Gravitational forces also cause the Moon to orbit the Earth and the Earth and other planets to orbit the Sun. Gravity causes our Sun to orbit the galactic centre.

Falling objects

It seems logical that heavier objects should fall faster than lighter ones, but Italian scientist and mathematician Galileo Galilei (1564–1642) found that the acceleration due to gravity is the same for all similarly shaped objects. Newton later discovered that the acceleration due to gravity depends on the mass of the planet and distance from the centre of the planet, but not on the mass of the falling object.

On the Earth’s surface, the acceleration of all objects due to gravity is 9.8 m/s^2 . This means that the speed of a falling object increases about 10 m/s for every second of its fall. This value is for objects falling in a vacuum. In air, acceleration will be slightly less and will depend more on the shape and density of the object, due to friction from the air.



Fig 6.6.1 The rock climber’s weight force is balanced only by her hand grip on the rocks and the friction of her boots.

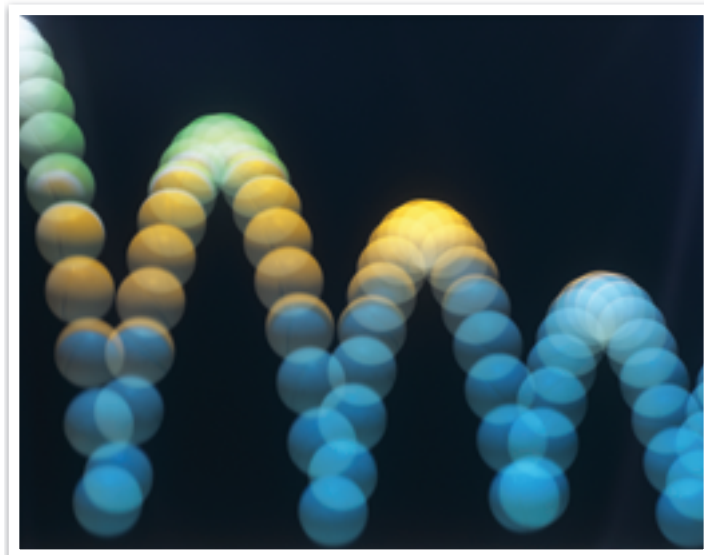

Fig 6.6.2 The spacings in this composite high-speed photograph show that gravity causes the ball to accelerate as it falls and decelerate as it bounces back up.

Weight

The force on a mass that is caused by gravity is called **weight**. It is the force that pulls objects down toward the centre of a planet. Weight depends on the mass of the object and the acceleration due to the gravity of the planet itself. You can write this as:

$$\text{weight} = \text{mass} \times \text{acceleration due to gravity}$$

$$\text{or } w = mg$$

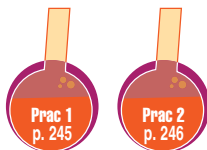
**Terminal velocity**

An object pushes air out of its way as it falls. The air pushes back with an upward force called **air resistance**. The greater the air resistance, the lower the acceleration of the fall. This is why a feather will fall much more slowly than a steel ball bearing in air—it has greater air resistance. In a vacuum, both would fall with exactly the same acceleration, and hit the ground at the same time.

Science Clip**Falling from the sky**

Without a parachute humans have a terminal velocity of about 50 m/s. However, skydivers can control their descent by changing the shape of their body as they fall, enabling them to 'hang back' or catch up to others to create group formations. An open parachute reduces the terminal velocity to 5 m/s, which is just about the terminal velocity of a raindrop (7 m/s). Pulling on the chute's strings changes its shape, which changes its speed and direction.

Leonardo Da Vinci (painter of the *Mona Lisa*) sketched his ideas for a parachute in 1485. In 1797, Andre Gamin completed the first successful parachute jump, having dropped 680 m from a hot air balloon.



Fig 6.6.3 Skydivers can change their terminal velocities.

Science Clip**g-forces**

Our weight often seems to increase because of inertia and **g-force** is used to describe this. Normally you only feel 1 g (i.e. normal gravity, g). If you experience 2 g, then you are being pushed into your seat twice as much as normal. The body responds, squashing muscles and bones.

Formula 1 drivers experience forces of up to 5 g when cornering: neck muscles strain to hold in place a head five times 'heavier' than normal and blood is 'pushed' sideways. Blood flow to the edges of the eye is disrupted, causing peripheral (side) vision to deteriorate, distorting perspective and making it difficult to judge distances.

If an aircraft suddenly increases altitude, blood moves down to the feet and away from the brain. At 8 g to 9 g, this reduced blood supply to the brain will cause blackouts.

Science Fact File**Gravity**

- Symbol in formulae: g
- Unit: metres per second squared (gravity is acceleration)
- Unit abbreviation: m/s^2 or ms^{-2}

Weight

- Symbol in formulae: w
- Unit: newtons (weight is a force)
- Unit abbreviation: N



Fig 6.6.4 Leonardo Da Vinci's 1485 sketch of a parachute

Science
Clip

Weightlessness

You have weight whenever gravity is around. True weightlessness (where $g = 0$) only happens far from the influence of stars and planets. You sometimes 'feel' weightless, however, in rides such as the Tower of Terror and the Giant Drop at Dreamworld, when the seat (with you in it) falls. During the fall, the seat cannot push back to give your normal 'feelings' of weight. When in orbit, the space shuttle and space stations fall towards Earth. They don't hit, however, since they are travelling at such high speed 'horizontally' that they always miss the planet. Astronauts aboard them have the 'feeling' of weightlessness because both they and the floor fall at the same rate.

Go to  Science Focus 3 Unit 8.5

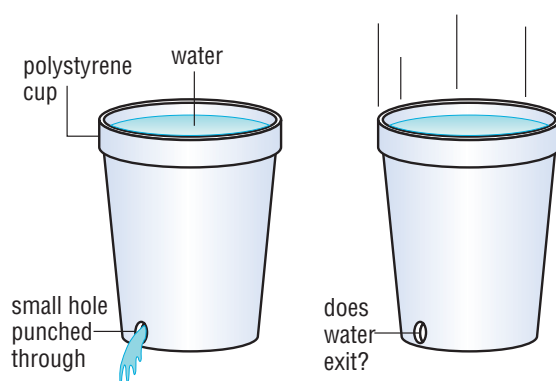

Fig 6.6.5 Try this experiment to show that water is 'weightless' when in a falling cup.

Air resistance increases as speed increases—the faster you are falling, the more the resistance. Eventually the upward force of air resistance balances the downward force of weight, and so the total force acting is zero. There can be no more acceleration and the object falls at a constant speed, called its **terminal velocity**. All objects have a terminal velocity, but its value will

depend on the shape and size of the object. A sheet of paper has high air resistance and a low terminal velocity, while the same paper crumpled into a tight ball has lower air resistance and will reach higher speeds.

 **Worksheet 6.6** Weight

6.6 QUESTIONS

Remembering

- 1 **State** the symbol, abbreviation and units for gravity.
- 2 **State** the rate at which all objects accelerate on the Earth's surface when in a vacuum.
- 3 **State** the relationship between weight and mass in words and a formula.
- 4 **List** factors that affect terminal velocity.

Understanding

- 5 **Define** the terms:
 - a gravity
 - b air resistance
 - c weight
 - d terminal velocity
- 6 **Copy** the following and modify any incorrect statements to make them true.
 - a Heavier objects fall faster than light ones.
 - b Air resistance is high in a vacuum.
 - c Mass changes as you move between different planets.
 - d Weight is measured in kilograms.
 - e You would feel weightless in a falling lift.
- 7 Spacecraft often have fragile solar panels and antennae projecting from them, but they move at very high speeds. **Explain** why these things don't get ripped off the craft.
- 8 **Account** for the fact that skydivers could throw a pumpkin back and forth between them before they release their chutes, but not once the chutes are open. (Hint: the terminal velocity of a pumpkin is 50 m/s.)
- 9 **a Explain** what is meant when it is said that a person experiences a force of 8 g.
 - b **Predict** what will happen to a human experiencing 8 g.
- 10 When the space shuttle is in orbit, the gravity on its occupants is still approximately 7 m/s^2 . **Account** for the fact that they seem weightless.

>>

11 Complete the 'photographs' in Figure 6.6.6 by **predicting** where the missing object is at each indicated time.

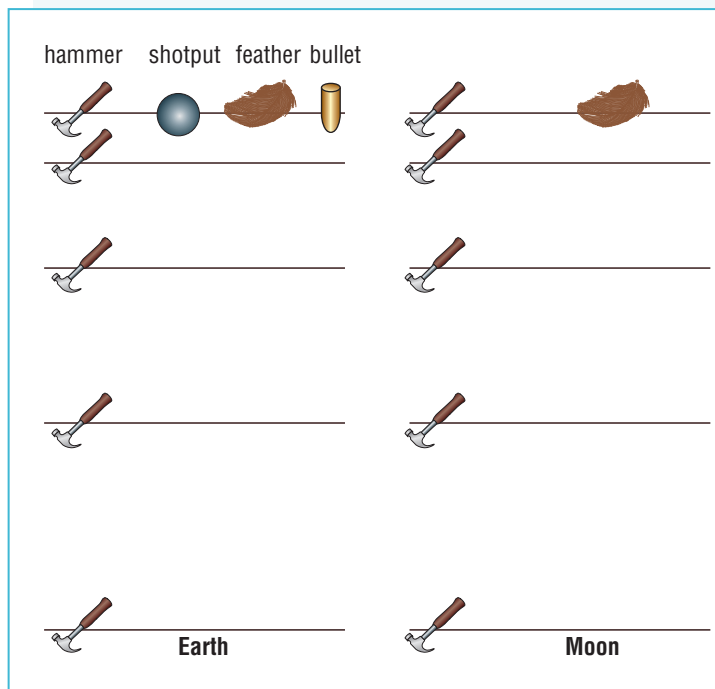

Fig 6.6.6

Applying

- 12 **Identify** a place that has no air resistance.
- 13 **Identify** the diagram in Figure 6.6.7 in which the ball will be:
- accelerating
 - getting blown upwards
 - travelling at terminal velocity

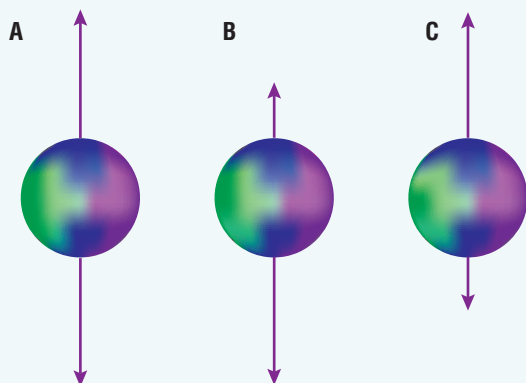

Fig 6.6.7

14 Amal has a mass of 50 kg. **Calculate** her mass and her weight on:

- Earth ($g = 9.8 \text{ m/s}^2$)
- the Moon ($g = 1.63 \text{ m/s}^2$)
- Mars ($g = 3.7 \text{ m/s}^2$) **N**

Analysing

- 15 Angelo lands on the Planet X. His mass is 70 kg on Earth.
- State** his mass on Planet X. **N**
 - If his weight on Planet X is 350 N, **calculate** the acceleration due to gravity on Planet X. **N**
 - Contrast** the size of Planet X with that of Earth.
- 16 **Contrast** weight with mass.
- 17 **Compare** the rate at which a hammer and a feather would fall on the Moon.

Evaluating

- 18 **Assess** whether it is possible to be truly weightless, even in space.
- 19 **a Propose** ways in which the g-forces on a human can be increased.
- b Propose** ways in which these forces can be decreased.

Creating

- 20 The ancient Greek philosopher Aristotle's views on gravity shaped thought for over 1500 years. Unfortunately, Aristotle thought heavier objects always fell faster than light ones. Imagine you have travelled back in time to explain to Aristotle what gravity is and what it does to falling objects. **Construct** some simple demonstrations to convince him.
- 21 Record a cartoon from TV, or find one on YouTube or elsewhere online. Watch the movements that it shows, particularly anything that is falling. **Construct** a presentation on a short snippet of motion shown in the cartoon. Were the laws of physics displayed correctly? If not, what should have happened? Show the snippet to the class and explain the physics.
- 22 Use datalogging equipment, appropriate sensors (e.g. light gates) and equipment (e.g. TAIN has 'combs') to **design** your own experiment to measure and plot the acceleration due to gravity.



6.6 INVESTIGATING

Investigate your available resources (for example, textbooks, encyclopaedias, internet) to complete the following tasks.

- 1 Research Galileo's gravity experiments on top of the Leaning Tower of Pisa. Summarise your findings by drawing a cartoon.
- 2 Write a biography of Sir Isaac Newton, highlighting his major scientific achievements. **I**
- 3 **a** Research the history of the parachute, and present your information in a style of your choice.
b Construct a series of diagrams to show the forces acting during the different stages of descent of a parachute.
- 4 **a** Record the value of gravity on different planets of the solar system.
b Calculate your weight on each planet. **N**

e-xploring



To **investigate** terminal velocity further, a list of web destinations can be found on *Science Focus 4 Second Edition Student Lounge*. You will need to complete the interactive animation investigating the physics involved when you drop a ball. Make changes to mass, radius and height of drop, and graph the results. Record your results in a table and state a conclusion about your findings.

6.6 PRACTICAL ACTIVITIES

1 Finding g using a ticker-timer

Aim

To experimentally determine acceleration due to gravity

Equipment

- ticker-timer and about 2 m tape
- G-clamp
- 50 g mass
- sticky tape
- ruler
- access to a calculator

Method

Option 1

- 1 Tape a 50 g mass to the bottom of a 2 m long strip of ticker-timer tape.
- 2 Clamp, or hold securely, the ticker-timer against a wall or doorframe.
- 3 Thread the tape into the timer and hold it.
- 4 Turn on the timer and let the tape fall.
- 5 Rule a line through every fifth dot. Measure the distance between each line.
- 6 Copy the table below and enter your results.

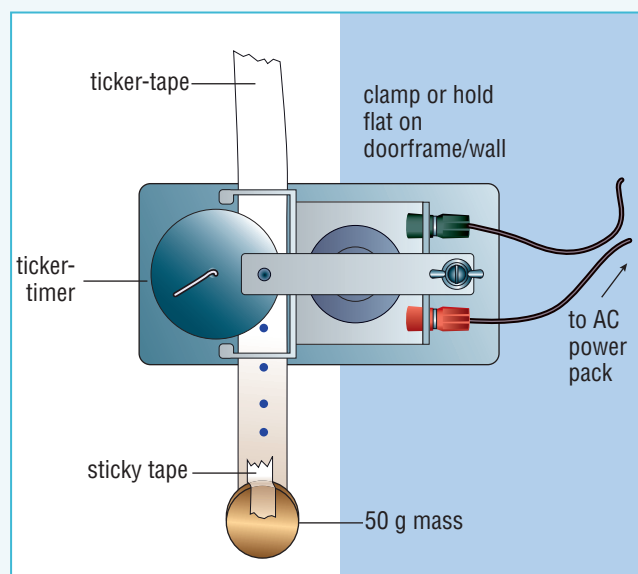

Fig 6.6.8 Using a ticker-timer to measure g

- 7 Calculate the average speed of each five-dot section. **N**
- 8 Plot a speed–time graph for the drop, drawing a line of best fit through your points.
- 9 Find the gradient of the graph. This is acceleration due to gravity in mm/s^2 . To convert to m/s^2 , divide by 1000. **N**
- 10 How does your result compare to the actual value of the acceleration of gravity of 9.8 m/s^2 ?

>>

Questions

- 1 Calculate** how long it would take for 1 new dot (equivalent to a space between 2 dots) and for 5 new dots (five spaces between 6 dots) to be produced if the AC supply was:
- 10 Hz
 - 100 Hz **N**
- 2 Explain** what the slope of a speed–time graph indicates.
- 3 Discuss** whether your graph indicates constant acceleration as the mass fell.
- 4** Why would the acceleration measured here be less than 9.8 m/s^2 ? **Justify** your answer.
- 5** From the tape, **describe** how you can tell when the mass hit the ground.

Selection	Elapsed time (s)	Time taken for each section (s)	Distance of each section (mm)	Average speed in each section (mm/s) Column 4 ÷ Column 3	Time at which this happened (s)
0 to 5 dots	0.1	0.1			
6 to 10	0.2	0.1			
11 to 15	0.3	0.1			
16 to 20	0.4	0.1			
21 to 25	0.5	0.1			

2 Measuring height with a stopwatch!

The formula $h = 4.9t^2$ gives the height that an object drops (measured in metres) when the drop time t is measured (in seconds). It assumes that the object falls with an acceleration of 9.8 m/s^2 due to gravity.

Aim

To find height using a stopwatch

Equipment

- any small mass that won't break
- stopwatch
- metre ruler/ tape measure
- string with mass attached

Method

- Find appropriate safe spots around school where you can drop a small mass.

- Measure the time taken for the drop at each place. Repeat to obtain consistent results.
- Use a calculator and the formula $h = 4.9t^2$ to calculate the expected height of the drop. **N**
- Use the tape measure to find the actual drop.
- Place all your results in a table like the one below.
- If time allows, test whether the formula works for the mass being thrown down (instead of being dropped) and for masses that have high air resistance.

Questions

- You both measured and calculated the height of the drop. **Compare** your results.
- Evaluate** whether the formula would give inaccurate results for the drop of things like a feather.
- Identify** the starting speed required for the formula to work.
- Present** any assumptions made by the formula.

Place of drop	Time of drop (s)	Average time (s)	Height from formula (m)	Measured height (m)

context

Studying science can sometimes seem like hard work! But in science a special definition of the word 'work' is used. If a force is applied to an object and moves the object, work has been done. That is

why the phrase 'hard work' really makes sense when you lift rocks and stack boxes. You probably use a little less energy doing your homework, which, scientifically speaking, is not really work after all.

Work

Movement involves **energy**. Energy is the ability to do **work**. Work happens whenever things are shifted or rearranged by a force. The bigger the force, the more work done. Likewise, if something is shifted a long way, then more work is done than if it only moves slightly. If it doesn't move, then no work has been done on it.

$$\text{work} = \text{force applied} \times \text{distance shifted}$$

or $W = Fs$

Force is always measured in newtons (N) and distance in metres (m). Work is a form of energy and, like all energy, is measured in **joules**, abbreviated as J.

If a heavy box takes a force of 500 N to shift it 3 m, then the work done on it is:

$$W = 500 \times 3 = 1500 \text{ J}$$

The work done in a car crash is very obvious. The car and its occupants can undergo radical rearrangement:

bonnets crumple, windscreens shatter, bones break. Forces are applied and things moved. Work is done. Where did the energy to do this work come from?

Science Fact File

Energy

- Unit: joules
- Unit abbreviation: J



Fig 6.7.2 If the crate shifts 3 m, then 1500 J of work has been done.

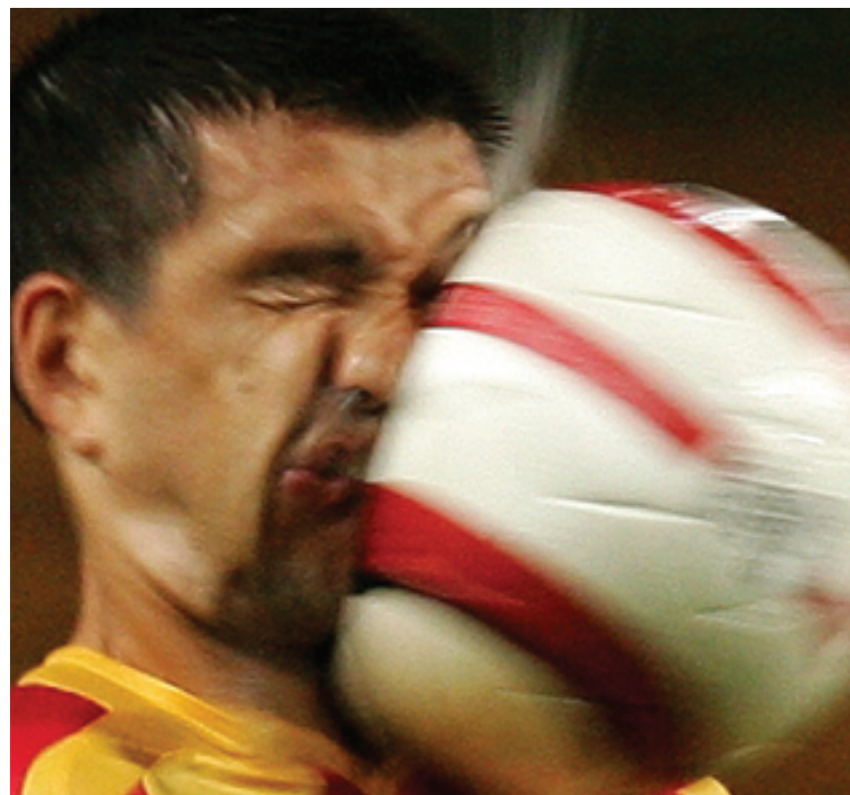

Fig 6.7.1 This ball has kinetic energy because it is moving. The ball is elastic and will bounce back to its original shape. The bones in the player's face are only partly elastic: go too far, and they break. Work has been done.



Fig 6.7.3 Anything that is moving has kinetic energy.

Kinetic energy

Movement is needed for cars to crash: no accident will happen if everything is stationary. When something moves it has **kinetic energy**. The heavier the car, the more kinetic energy it has and the more work and damage it can do. Likewise, the faster something travels, the more work will be done if it collides. In fact, if speed is doubled, the work done in a collision and the damage caused will be four times what it was at the slower speed.

$$\text{Kinetic energy} = \frac{1}{2} \times \text{mass} \times \text{speed} \times \text{speed}$$

$$\text{or } KE = \frac{1}{2} mv^2$$

Kinetic energy is measured in joules (J), mass in kilograms (kg) and speed in metres per second (m/s).

Compare the kinetic energies of a typical 1.5 tonne car (1500 kg). At 50 km/h (13.9 m/s), the car has a kinetic energy of

$$\begin{aligned} KE &= \frac{1}{2} \times 1500 \times 13.9^2 \\ &= 144\,908 \text{ J} \end{aligned}$$

At 100 km/h (27.8 m/s), the kinetic energy is quadrupled:

$$\begin{aligned} KE &= \frac{1}{2} \times 1500 \times 27.8^2 \\ &= 579\,630 \text{ J} \end{aligned}$$

On braking, all this kinetic energy is converted into heat energy that is dissipated by the brake pads or discs. The brake discs of racing cars sometimes glow red hot as they dissipate the energy of braking for corners. In a collision, the energy converts into heat and sound, but mainly into work as the car crumples or crumples other cars or objects—a lot of rearranging is done in an accident.

Gravitational potential energy

Similar damage would be sustained if a car ran off a cliff. The higher the cliff, the worse the situation becomes. Obviously height gives you energy too.

Potential energy is stored energy—it gives the object the potential to do work. If you lift an object to a height you give it **gravitational potential energy**. The heavier the object and the higher you lift it, the more energy it will have, and the more damage it will cause when let go.



Fig 6.7.4 This gymnast is slowest at the top of his swing. He has lots of gravitational potential energy but not much kinetic energy. As he falls, gravitational potential energy converts into kinetic energy. As a result, he travels fastest at the bottom of his swing.

Mathematically it can be written as:

$$\text{Gravitational potential energy} = \text{mass} \times \text{acceleration due to gravity} \times \text{height}$$

$$GPE = mgh$$

GPE is measured in joules (J), m in kilograms (kg) and h in metres (m). Like all accelerations, g is measured in metres per second squared (m/s^2). On Earth, g is 9.8 m/s^2 .

As something falls it picks up speed—gravitational potential energy is converted into kinetic energy. When it hits the bottom, most will be converted into work done on the ground and the object itself. Both the ground and the object will dent and change shape or break.

Elastic potential energy

Elastic bands and springs store energy when they are stretched or extended. They store it as **elastic potential energy**. They have the potential to release energy and

do work when they are let go, bouncing back to their original shape. This is very obvious when a slingshot is stretched and let go. You put your own energy into stretching the elastic band. The more a slingshot is stretched, the more energy it stores, the more kinetic energy the projectile will have, the faster it will go and the more damage (work done) it will do. This is also the energy that puts the fun into bungee jumping.

Springs also store energy when squashed or compressed. Tennis balls act as a store of elastic potential energy when compressed on a bounce or when hit. The more the ball stores, the more it releases and the higher it will bounce.



Fig 6.7.5 A balloon stores elastic potential energy as it stretches, ready to release it as it bounces back to its original size and shape when let go or when it is burst.

Some materials are stiff—they need high forces to change their shape. Others are highly elastic. One measure of stiffness is the **spring constant** of the material. The higher the constant, the stiffer (and less elastic) it will be.

$$\text{Elastic potential energy} = \frac{1}{2} \times \text{spring constant} \times \text{extension}^2$$

$$EPE = \frac{1}{2} kx^2$$

Here, x is the extension or compression of the elastic band or spring (measured in metres) and k is its spring constant (in newtons per metre, N/m).

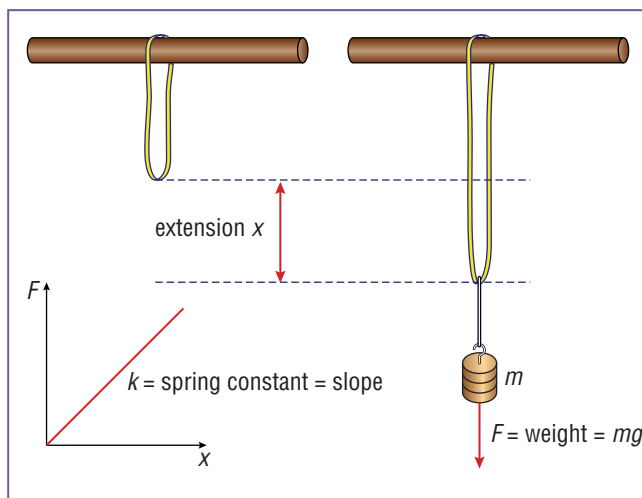

Fig 6.7.6 Calculating the spring constant

Efficiency

Friction between moving surfaces wastes useful energy, converting some of it into heat and sound. **Efficiency** is a measure of how much useful energy is retained in a conversion:

$$\text{efficiency} = \frac{\text{useful energy after the conversion}}{\text{energy before the conversion}} \times 100\%$$

A rolling ball will eventually stop due to friction. All the kinetic energy it once had has been converted into heat and sound. A 100 per cent efficient machine would be perfectly quiet and would run forever because all the energy conversions would be perfect. Unfortunately, this is impossible—there is no such thing in our universe as perfect efficiency. Every system loses energy and slows down unless more energy is added.

A ball loses a little of its useful energy each time it bounces. Squash balls have very little bounce and are incredibly inefficient, losing most of the energy to heat. One way of comparing the efficiency of different kinds of balls is to observe how much of their original height they can regain on a bounce. A tennis ball might be 60 per cent efficient—if it is dropped from a height of one metre, it will bounce 60 cms high the first time, 36 cm the second time, about 22 cm the third time and 13 cm the fourth time. A squash ball might only be 10 per cent efficient if it is cold, but it gets more efficient as it warms up.



Science Clip

Impossible bounce

The 1997 movie *Flubber*, starring Robin Williams, illustrates what would happen if it were possible to create a bouncing ball with efficiency greater than 100 per cent. Such a ball would keep increasing the height of its bounce each time, eventually bouncing high enough to go into orbit. Perhaps it's just as well this is impossible.



6.7 QUESTIONS

Remembering

- 1 **State** the name, abbreviations and units for all terms in the equation: $W = Fs$
- 2 **State** the type of energy a moving object possesses.
- 3 **State** the units for the terms in the kinetic energy equation.
- 4 **List** two objects capable of storing elastic potential energy.
- 5 **State** the units for all terms in the formula:

$$GPE = mgh$$

- 6 **List** the springs in Figure 6.7.7 in order from stiffest to least stiff.

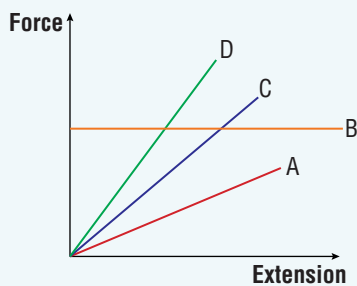

Fig 6.7.7

Understanding

- 7 **Define** the terms:
 - a energy
 - b kinetic energy
 - c gravitational potential energy
 - d elastic potential energy
 - e efficiency
- 8 Use words to **explain** the following equation:

$$W = Fs$$
- 9 Use words and symbols to **describe** the formula used to **calculate**:
 - a kinetic energy
 - b gravitational potential energy
 - c elastic potential energy
- 10 **Describe** how friction wastes energy.
- 11 Crumple zones are incorporated into the front and rear of modern cars to convert the energy of the collision into work on the panels. It does this by allowing them to buckle instead of remaining rigid. If these zones were not there, **predict** what would absorb the collision energy.

Applying

- 12 **Identify** the forms of energy that could be called:
 - a 'moving' energy
 - b 'height' energy
 - c 'spring' energy
 - d 'rearranging' energy
- 13 Write an equation to demonstrate how efficiency can be calculated.
- 14 **Identify** the situations in the list below that do not involve any work being done.
 - a A 10 kg crate is lifted up 2 m.
 - b A car is pushed along a road.
 - c A spacecraft travels through the solar system without being affected by air resistance or gravity.
 - d A skateboard rolls to a stop.
 - e A book sits on a desk.
- 15 Figure 6.7.8 shows the graphs for the extensions of the elastic band combinations shown. **Identify** the graph that matches each elastic band combination.

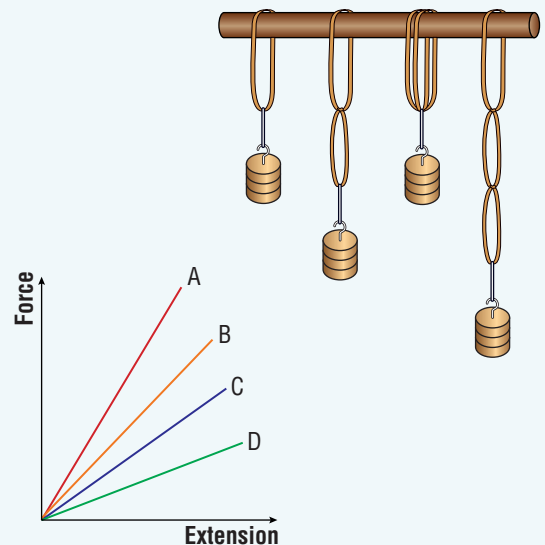

Fig 6.7.8

- 16 **Calculate** the work done:
 - a by a 7 N force that shifts a box 2 m
 - b in shifting a trolley 50 cm by a 20 N force **N**

- 17 Calculate** the kinetic energy in the following:
- a** A 400 kg motorbike is travelling at 25 m/s.
 - b** A 50 kg skateboarder is freewheeling at 9 m/s.
 - c** A 20 g stone is thrown at 2 m/s. (Note: 1000 g = 1 kg.)
 - d** A 30 mg spider runs about at 5 cm/s. **N**
- (Note: 1000 mg = 1 g.) **N**
- 18 Calculate** the gravitational potential energy that the following objects have.
- a** Travis stands on a diving board, 11 m above the surface. His mass is 60 kg.
 - b** A 2.5 kg textbook is on a desk that is 70 cm high. (Note: 100 cm = 1 m.)
 - c** Matthew (65 kg) is on the Centrepoint observation deck, 250 m above the street.
 - d** Yee is piloting Flight 007 at a height of 9500 m. Her mass is 55 kg.
- 19** Tanya is about to dive off the 10 m board. Her mass is 50 kg.
- a Calculate** her gravitational potential energy before the dive. **N**
 - b** This energy had to come from somewhere. **Predict** where. (Hint: How did she get there?)
 - c** When she dives, **predict** the potential energy conversion.
 - d Specify** evidence for the energy conversion in part c.
 - e Calculate** her kinetic energy just before she enters the water.
 - f Describe** where all this kinetic energy goes when she enters the water.
- 20 a Calculate** the gravitational potential energy before and after a bounce, if a 30 g ball is dropped from 2 m and bounces to a height of 1.5 m. **N**
- b Calculate** its efficiency. **N**
- 21 Calculate** the elastic potential energy stored in each spring (make sure all lengths are in metres). **N**
- a** A slinky spring with a spring constant 5 N/m is extended 3 m.
 - b** A spring ($k = 25$ N/m) is squashed 0.5 m.
 - c** A slinky has a natural length of 15 cm, but is stretched to a new length of 90 cm. Its spring constant is 30 N/m.
 - d** The slinky in part c is stretched from 15 cm to 4 m in length.

Analysing

- 22** A slingshot that is stretched twice as far does roughly four times the damage. **Analyse** the reasons for this result.
- 23 Compare** the elastic potential energy stored in an elastic band (spring constant 6 N/m) that is stretched 0.1 m with an identical band that is stretched exactly double the distance.

Evaluating

- 24** *If speed is doubled, the car accident will be twice as bad.* Use your knowledge of kinetic energy to **evaluate** this statement.
- 25 a** *A tennis ball that was 100 per cent efficient would bounce forever.* **Assess** this statement.
- b** In reality, a tennis ball will bounce a little less each time. **Explain** why this occurs.

6.7 INVESTIGATING

Investigate your available resources (for example, textbooks, encyclopaedias, internet) to complete the following tasks.

- 1** Research the methods used to stop a lift falling if the cables break. Record your findings in the form of a safety report that might appear on an advertising brochure.
- 2** Explain what a leaf spring is and how it is used in the suspension of some cars and trucks.
- 3** Search the websites of the major car manufacturers to:
 - a** identify the safety features included in modern cars, and list them as active or passive features. Active safety features are those that allow a driver to avoid an accident in the first place (e.g. brakes, tyre tread, headlights). Passive safety features protect the occupants when an accident occurs (e.g. seatbelts, energy-absorbing bumpers)
 - b** design a new safety feature for cars that does not currently exist, but you think may be worth including in cars in the future.

6.7 PRACTICAL ACTIVITIES

1 Extension of an elastic band

Aim

To measure the elasticity of elastic bands

Equipment

- three similar elastic bands
- retort stand
- bossheads and clamps
- 50 g masses
- ruler

Method

- 1 Copy this table into your workbook.

Mass attached (g)	Length (mm)	Extension (mm)
0		
50		
100		
150		
200		
250		

- 2 Measure the natural, unstretched, length of an elastic band.
- 3 Hang a single band from the retort stand and attach a single 50 g mass.
- 4 Measure its new length and calculate the extension the 50 g mass has caused.
- 5 Repeat for 100 g, 150 g, 200 g and 250 g.
- 6 Plot a graph of mass (g) (vertical axis) against extension (mm). Draw a line of best fit through the points.
- 7 Repeat the process for the other elastic band arrangements shown in Figure 6.7.9.
- 8 On the same graph as before, plot the graphs of these arrangements.
- 9 Repeat the experiment using elastic bands of different thicknesses.

Questions

- 1 **Identify** the energy being stored in this experiment.
- 2 **Discuss** which arrangement of the elastic band was the stiffest.

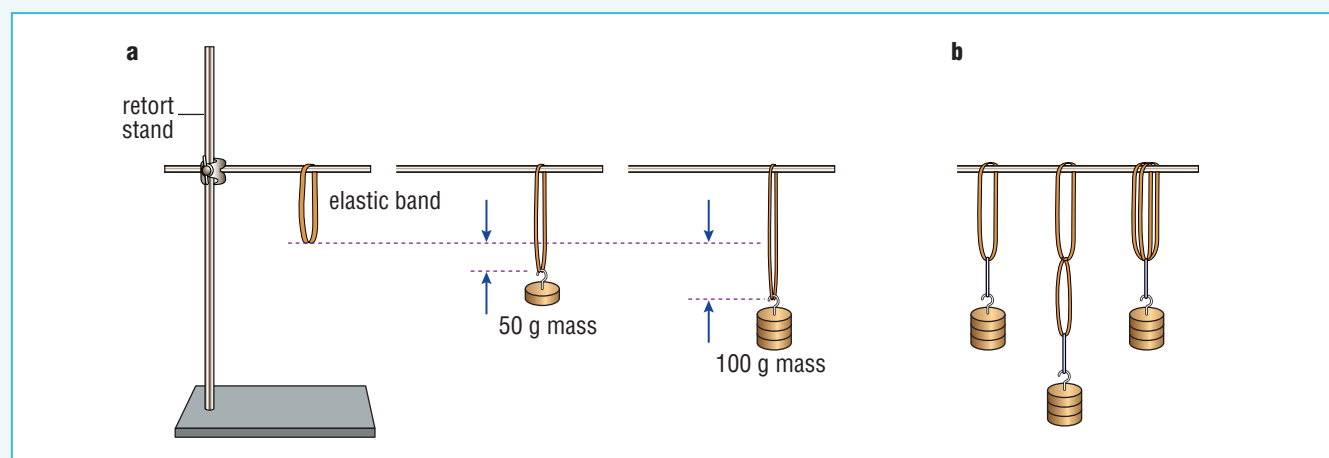

Fig 6.7.9

2 Efficiency of a roller coaster

Aim

To design a roller coaster and determine the efficiency of different-shaped curves

Equipment

- material to make a track (clear plastic tubing is ideal)
- ballbearing or marble
- retort stands
- bossheads and clamps
- metre ruler
- access to electronic scales

Method

- 1 Set up the roller coaster as shown.
- 2 Let the marble run from one end of the track to the other.
- 3 Measure the starting and finishing height.
- 4 Determine the mass of the marble.
- 5 Calculate the gravitational potential energy of the marble at the beginning and end of the track. **N**
- 6 Calculate the efficiency of the track. **N**
- 7 Change the shape of the track and repeat.
- 8 Find the most efficient and inefficient shapes for the track. Draw them.

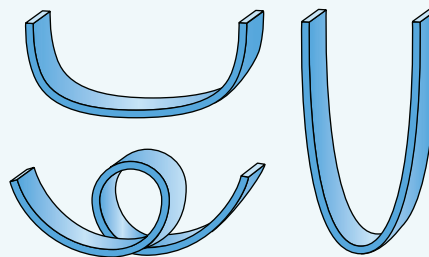
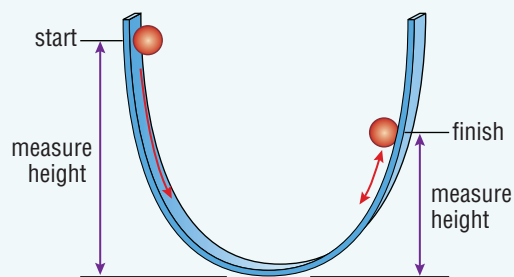

Fig 6.7.10

Questions

- 1 Gravitational potential energy is converted into other forms as a marble drops. **Deduce** what forms it is converted into.
- 2 **Identify** the type of energy the marble had at the bottom.
- 3 The track will never be 100 per cent efficient. **Explain** why.

3 Ball bounce

The coefficient of restitution of a ball is a measure of the rate at which a ball regains its shape on a bounce. It can be calculated by the formula:

$$\text{coefficient of restitution} = \sqrt{\frac{\text{height of bounce}}{\text{height of drop}}}$$

Aim

To calculate the coefficient of restitution of various balls

Equipment

- a variety of balls (tennis, squash, superball, basketball)
- metre ruler

Method

- 1 **Design** your own experiment to measure the coefficient of restitution of different balls from a particular height.
- 2 Run a further test to see if the coefficients change when the starting height is changed.



Questions

- 1 **List** the balls in order from highest to lowest coefficients of restitution.
- 2 **Deduce** whether the coefficient of restitution was the same for each ball for each drop height.
- 3 A coefficient of 1 is impossible. **Explain** why.
- 4 Use your observations to **discuss** where the energy goes in a bounce.
- 5 Apart from ball type and height, **identify** other variables that could affect the coefficient of restitution.

CHAPTER REVIEW

Science
Fact File

Newton's three laws

Newton's First Law

An object at rest will stay that way unless a force acts on it. An object in motion will continue to move in the same direction at the same speed until a force acts on it.

Newton's Second Law

If an unbalanced force is applied to an object, the object will accelerate. The acceleration will depend on the size of the force and the mass of the object.

$$\begin{aligned} \text{force} &= \text{mass} \times \text{acceleration} \\ \vec{F} &= m \times \vec{a} \end{aligned}$$

Newton's Third Law

For every force there is a force of the same size acting in the opposite direction. We sometimes call one force the action force and the other one the reaction force. The action and reaction forces act on different objects.

Remembering

- State the symbols normally used for the following quantities:
 - distance
 - speed
 - acceleration
 - force
 - mass
- State what a driver is doing during reaction time and braking time.
- List two things that need to happen for work to be done.

Understanding

- Use examples to explain what is meant by inertia.
- Outline Newton's three laws.
- Station wagons are more dangerous than sedans. Use your knowledge of inertia to explain why.
- Use $F = ma$ to explain why high jumpers and pole vaulters land on a spongy mat and not the hard ground.
- Dashboards are generally padded, but once were made of metal. Explain how a padded dash reduces impact force.
- Predict what doubling the speed would do to the kinetic energy.

- Predict the forms into which a car's kinetic energy will get converted in an accident.
- Squash balls don't bounce well and get very hot after a little play. Explain how these two facts are connected.

Applying

- From the following list, identify the most appropriate unit for the quantities below:

J N m/s² m/s m s °C

 - energy
 - displacement
 - time
 - velocity
 - acceleration
 - force
 - work done
- Identify which one of Newton's laws best explains these situations.
 - You feel a gun recoil.
 - You are 'pushed' back into the seat when a car accelerates away at traffic lights.
 - A hose flicks about when the water is turned on.
 - A hand passes through a piece of wood in a karate chop.
 - A soccer ball is kicked.
 - Sand moves under your feet when you run.
- Calculate any missing values in the following table and select the appropriate units for each. **N**

Distance travelled	Time taken	Speed
20 m	5 s	
	6 h	80 km/h
1000 km		100 km/h
2.5 cm	0.5 s	
7.0 m		35 m/s

15 Identify the graphs below that represent an object that is:

- a** at rest or stationary
- b** moving at constant speed
- c** accelerating
- d** decelerating

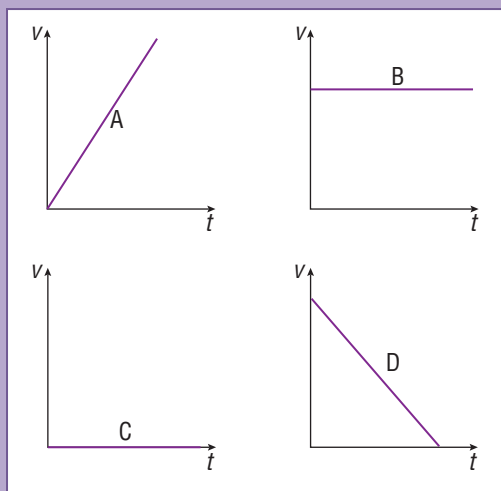

Fig 6.8.1

- 16 Calculate** the distance and displacement of a ball that is thrown vertically, rises to a height 3 m above your hand, and then returns to it.
- 17** The same ball is thrown up to the same height, but is dropped on its return, falling 1 m to the ground. **Calculate** its distance and displacement.
- 18** A cricket pitch is 20.1 m long. The ball is released 0.5 m behind the wicket and reaches the batter's wicket 0.83 s later. **Calculate** the average speed of the ball in m/s and km/h. **(N)**
- 19 Calculate** the final speeds of objects shown in this table. **(N)**

Starting speed	Accelerated for this time	Rate of acceleration	Final speed
0	5 s	15 m/s ²	
0	12 s	4 m/s ²	
18 m/s	6 s	2 m/s ²	
40 km/h	5 s	5 km/h/s ²	
20 m/s	Half a minute	3 m/s ²	

Analysing

20 Contrast the following:

- a** average and instantaneous speeds
- b** mass and weight
- c** work and force

Evaluating

21 *All things fall at the same rate.* Is this statement true, false or a bit of both? **Justify** your answer.

Creating

22 Construct likely speed–time graphs for each of these motions.

- a** A car accelerates away from traffic lights.
- b** A car travels at 100 km/h along a freeway.
- c** A car brakes hard.

23 On the one graph, **construct** speed–time graphs for these drops.

- a** A shotput is dropped from 2 m.
- b** A tennis ball falls 2 m to the ground.
- c** A piece of crumpled paper falls.
- d** A parachutist jumps out of a plane, waits a short time, opens the chute and then floats to the ground.

 **Worksheet 6.8** Crossword

 **Worksheet 6.9** Sci-words

 Chapter Review Questions

 Interactive

 Drag-and-drop

7 Electricity, electromagnetism and communications technology

Prescribed focus area

The applications and uses of science

Key outcomes

5.3, 5.6.1, 5.6.3, 5.9.1, 5.12

- Voltage, resistance and current can be explained using water as an analogy.
- Voltage, resistance and current are related to each other.
- Components in series split total voltage but carry the same current.
- Components in parallel split total current but use the same voltage.
- Waves are carriers of energy.
- A wave can be described using frequency, wavelength and speed.
- Different types of radiation such as visible light and radio waves make up the electromagnetic spectrum.
- Each type of radiation has its own use.

Essentials

Additional

- Ohm's law ($V = IR$) describes the mathematical relationship between voltage, resistance and current.
- Waves can be classified as transverse or longitudinal.
- The speed of light and sound relate to their frequencies and wavelengths.
- Different forms of electromagnetic radiation have different wavelengths and frequencies.
- Speed, frequency and wavelength are mathematically related by $v = f\lambda$.

context

In the Western world, we live in an 'electrical' society. Every day we use a wide variety of appliances that need

electrical energy to run: iPods, PSPs, toasters, televisions, microwave ovens and computers. Even the family car needs electricity.

A simple circuit



A circuit is a path from one side of a power source (e.g. a cell, battery or power pack) to the other. The three basic parts of a simple circuit are:

- an **energy source**, such as a **cell** or **battery**.
A cell or battery can be thought of as a charge pump
- a **conducting path** (wires) for the electricity to flow through
- an **energy user** or **load**, such as a globe, motor, buzzer, heating element or resistor.

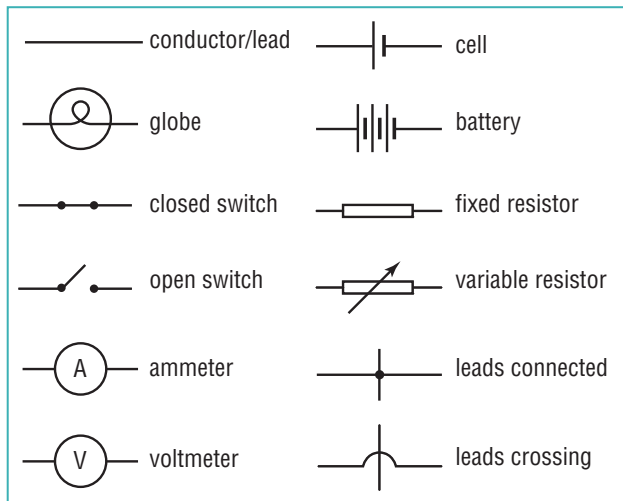

Fig 7.1.1 Common components in simple circuits



Fig 7.1.2 Electricity is transmitted over long distances as high voltage, low current AC electricity. Electricity is easier to transmit as AC than DC and less energy is lost in the transmission.

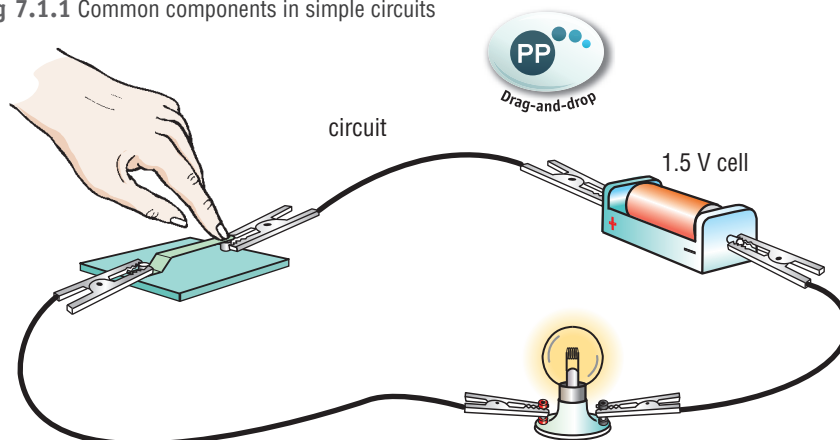
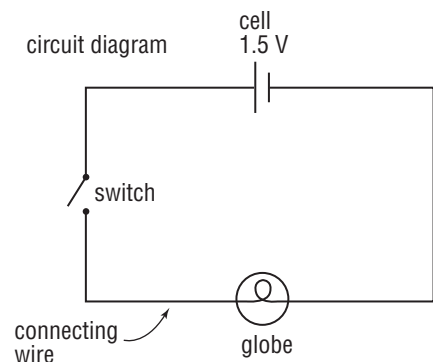

Fig 7.1.3 A simple circuit and its equivalent circuit diagram



Science
Fact File

Measuring electricity

Symbols in formulae	Current I	Voltage V	Resistance R
Units used	Amperes	Volts	Ohms
Unit abbreviations	A	V	Ω

Measuring electricity

There are three very important values in circuits that we can measure and calculate.

Current

An electrical **current** is flowing whenever a **charge** moves. In most circuits the moving charges are electrons and current is defined as the rate of flow of those electrons. Current is measured in **amperes** (unit symbol A), sometimes abbreviated to amps. In mathematical formulae, current is given the symbol I .

Sometimes in a circuit there will be more than one path that the current can take. More current will flow down the easier path and less down the harder one.

Voltage

Voltage is a measure of the energy carried or used by charge. Voltage measures how much energy is:

- available from the battery or power pack to push current through the circuit. Voltage can be thought of as the size of the push given to each charge that makes up the current
- used by current as it passes through a load such as a light globe, heating element or motor.

Voltage is measured in **volts** (unit symbol V) and is sometimes referred to as **potential difference**. Voltage is given the symbol V in mathematical formulae.

Resistance

Resistance is a measure of how much a load (e.g. globe, motor, resistor) restricts and reduces the flow of current. Resistance is measured in **ohms** (unit symbol Ω). In mathematical formulae, resistance is given the symbol R .

Using a water analogy

Electricity cannot be seen flowing around a circuit and so an analogy might help you understand what is happening. We will use the analogy of water being pumped through a hose. Not every feature in the analogy will be the same as what is happening in the circuit, but it will help you understand some new ideas.



Fig 7.1.4 Resistors restrict the flow of current. Variable resistors are commonly used as volume controls on radios, MP3 players, TVs and sound systems.

Digit	Colour
0	black
1	brown
2	red
3	orange
4	yellow
5	green
6	blue
7	violet
8	grey
9	white

tolerance (4th band)
gold 5%
silver 10%
no colour 20%

4 band resistor
first digit: yellow (4)
second digit: violet (7)
number of zeros: red (2 zeros (00))
= 4700 Ω
5% tolerance

5 band resistor
first digit: yellow (4)
second digit: violet (7)
third digit: black (0)
number of zeros: brown (1 zero (0))
= 4700 Ω
5% tolerance

Fig 7.1.5 The coloured bands represent the digits 0 to 9 and can be used to determine the resistance of a resistor.

In a water circuit, the pressure (P) supplied by the pump drives the water around the closed loop of a pipe at a certain flow rate (F). The waterwheel (W) restricts the flow of water using up its energy. The valve turns the flow of water on and off.

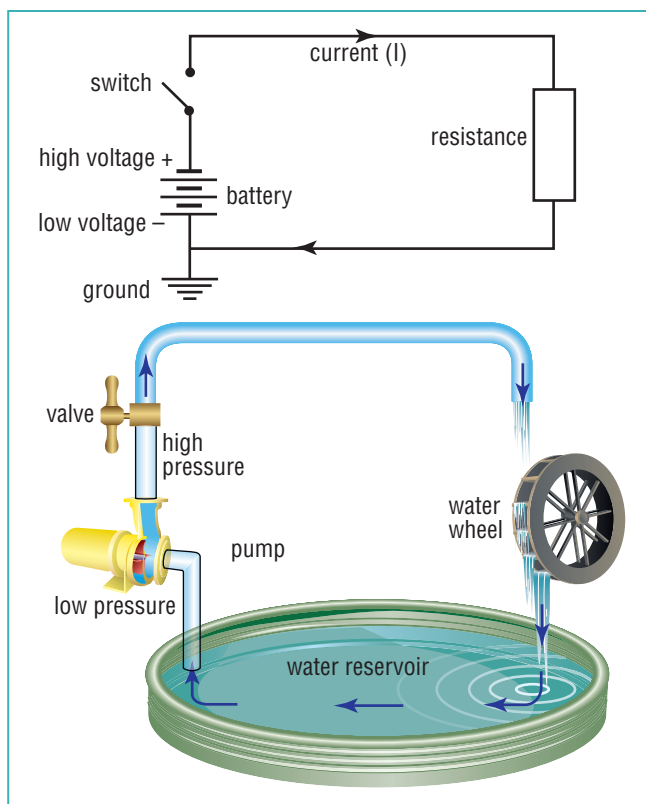

Fig 7.1.6 A water pump can be used as an analogy of an electrical circuit.

In an electrical circuit, the energy or voltage (V) supplied by the battery drives the electrons around the closed loop of a circuit, causing an electric current (I). The resistance (R) restricts the flow of electrons, using up their energy. A switch turns the flow of electricity on and off.

Water in pipe	Units	Electricity in wire	Units
Pressure (P)	Pascals	Voltage (V)	Volts
Flow rate (F)	Litres/second	Current (I)	Amperes
Resistance to flow (W)	Newtons	Resistance (R)	Ohms

A voltage analogy

A battery or power pack is the ‘pump’ of an electrical circuit. A water pump takes in water at low pressure, supplies energy to it and ejects it at high pressure. A battery or power pack takes in charge at low voltage, adds energy to it and ejects it at a higher voltage.

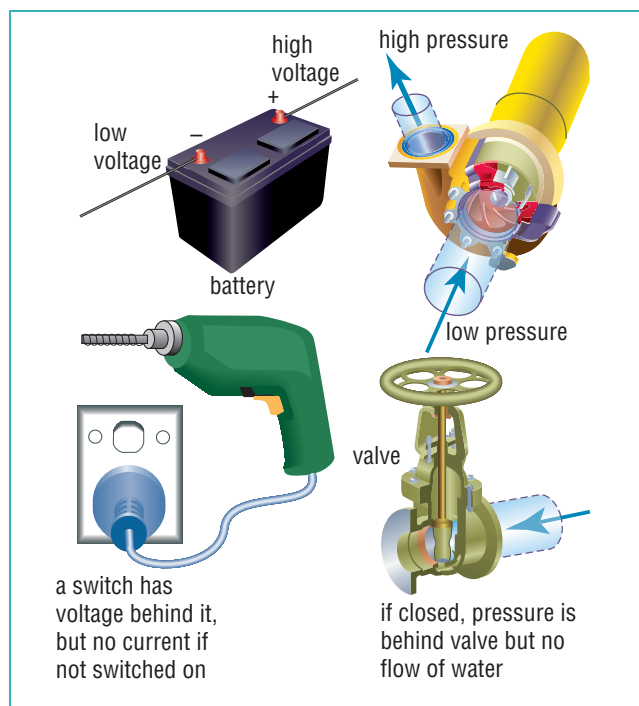

Fig 7.1.7 Voltage can be compared to the pressure of water in a pipe.

A current analogy

When current flows through a wire it moves freely, losing almost no energy. This is just like water in a pipe where there is little resistance to slow the water down. A higher current means more electrons flow past a point in a circuit every second.

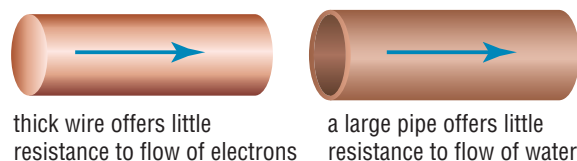

Fig 7.1.8 Current can be compared to the rate of flow of water through a pipe. The smaller the pipe, the lower the current.

Science Clip

Fatal currents

A current as small as 0.1 to 0.2 amps can kill! Most deaths associated with electric shock happen because the electricity interrupts the heartbeat which is controlled by small electrical currents. High voltages are more dangerous than low ones because they can drive a higher current through your body. The 240 volts in home power supplies is easily enough to drive a deadly current through your body.

A resistance analogy

A waterwheel restricts the flow of water, slowing the water down and taking away its energy. Light globes, buzzers, motors, heating elements and resistors are loads that restrict the flow of current and remove energy from the electrons. These loads change the electrical energy into other forms such as sound, light, heat and kinetic (moving) energy.

The filament of a light globe is a very thin wire. As the current tries to squeeze through, it encounters resistance and uses up some of its energy. That energy is transformed into heat energy that causes the wire to glow, providing light. In a thick wire, electrons move more freely and with little resistance. Little energy is lost.

Increasing the resistance of the circuit will cause a decrease in the current and result in more energy being used up by the load.

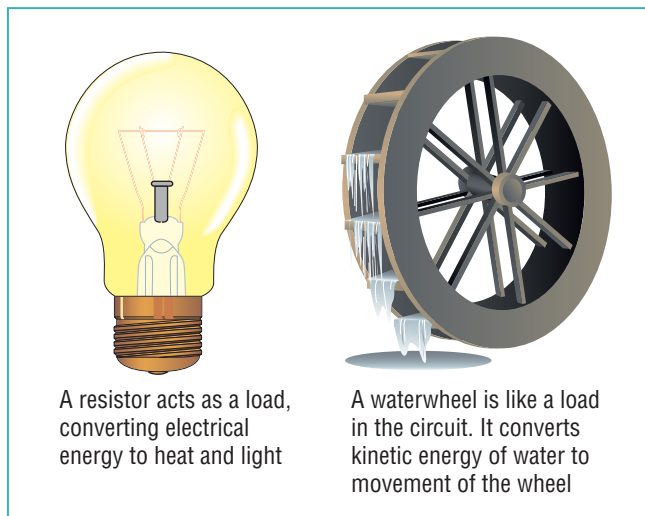

Fig 7.1.9 Resistance in a circuit can be compared to a waterwheel in a pumped circuit. Resistance uses up energy.

Science Fact File

Analogy breakdown!

Analogies might be a convenient way of learning about something like electricity but they do have their limitations. If a water pipe or hose is cut or is broken, then water pours out of the cut and will keep pouring out until the tap is turned off. If a wire is cut, however, electrical current does not leak out. In this way electricity acts very differently to water.



Fig 7.1.12 Although water flows out of a cut hose, electricity does not flow out of a cut wire.

Types of circuits

There are two basic types of circuits—series and parallel.

Series circuits

Two globes are said to be in series if they are arranged one after the other in a line with the battery. The voltage supplied is split between the two globes, but the current passing through each is the same. The two globes glow more dimly than a circuit with only one globe.

If a globe in this circuit is removed or 'blows', then the circuit is broken and the other globe will not work either.

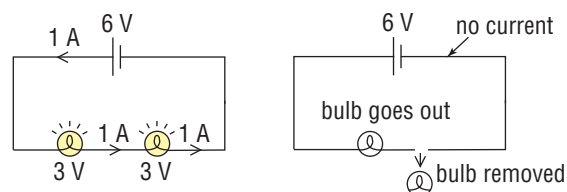

Fig 7.1.10 A series circuit with two globes

Parallel circuits

Globes arranged on separate branches of a circuit are said to be arranged in parallel, and this type of circuit is referred to as a parallel circuit. The voltage used by each globe is the same, but the current is split between each branch. Each globe glows with equal brightness.

If a globe in this circuit is removed or blows, then the other globe will remain lit as there is still a circuit through which current can flow.

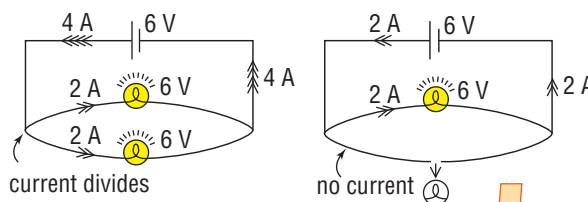
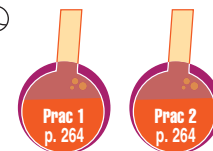

Fig 7.1.11 A parallel circuit with two globes



Ohm's law

Ohm's law describes the relationship between the current, voltage and resistance in a circuit. It basically states that if everything else is constant then:

- if resistance is increased and voltage remains the same the current will decrease
- if voltage is increased and resistance remains the same the current will increase.

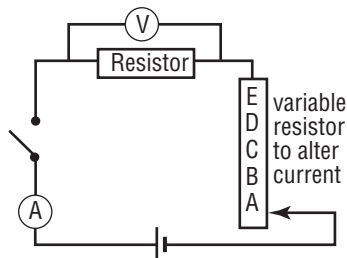

Fig 7.1.13 Current increases as voltage increases. Current decreases as resistance increases. This circuit has a variable resistance which allows the current in the circuit to be increased or dropped as needed. This circuit is used to prove Ohm's law.

Typical results from this experiment are shown in the table opposite.

A graph of these results shows that the electric current is directly proportional to the voltage. This can be expressed mathematically as $V \propto I$. This relationship means if the voltage is doubled, then so is the current. A graph of Ohm's law is therefore a straight line that passes through the origin.

Ohm's law is stated as:

$$\text{voltage} = \text{current} \times \text{resistance}$$

$$V = IR$$

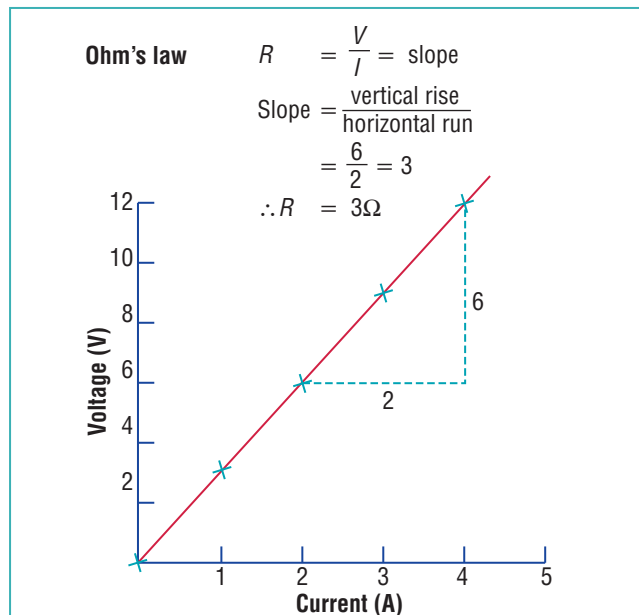
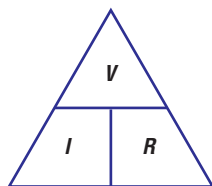

Fig 7.1.14 Ohm's law is shown by this graph. The slope or gradient of the graph gives us the resistance. It can also be calculated by dividing the voltage by the current, $R = \frac{V}{I}$.

	Voltage V (volts)	Current I (amps)
A	0	0
B	3	1
C	6	2
D	9	3
E	12	4

Worksheet 7.1 Ohm's law

Prac 3
p. 265



To use the triangle, cover what you wish to find with a finger. There are only three combinations.

- 1** Find the voltage used when a resistor of 10Ω has a current of 2 A flowing through it.

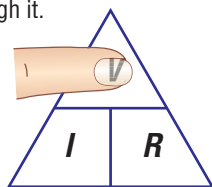

$$V = IR$$

$$= 10 \times 2$$

$$= 20 \text{ volts}$$

- 2** Find the current flowing through a resistor of 12Ω if the voltage supplied is 240 V.

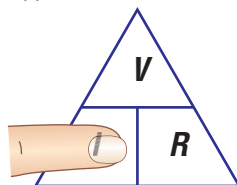

$$I = \frac{V}{R}$$

$$= \frac{240}{12}$$

$$= 20 \text{ A}$$

- 3** Find the resistance of a circuit of a 12 V battery that draws a current of 2 A.

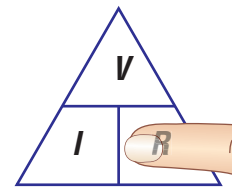

$$R = \frac{V}{I}$$

$$= \frac{12}{2}$$

$$= 6\Omega$$

Fig 7.1.15 This triangle can be used to calculate different values using Ohm's law. Simply cover the value that you want to find.

AC/DC

The difference between AC and DC is in the way the electrons move in the wire.

In **direct current** (DC) the electrons flow in one direction only. A battery or DC power pack provides a source of electrons and the potential difference or voltage between the terminals causes them to move from the negative (−) towards the positive (+) terminal. The flow of electrons through a wire can be thought of as similar to water in a hose—it only goes one way.

In **alternating current** (AC) the electrons shuttle back and forth in the wires. This occurs because the voltage at the power point or the AC power pack

Science Clip

Animal electricity

The **electric eel** (*Electrophorus electricus*) is an unusual species of fish that is capable of generating powerful electrical shocks. It can grow up to 2.5 metres in length and 20 kg in mass, and can produce 500 volts and 1 ampere of direct current. This is enough to kill a human!

constantly changes from positive to negative to positive and so on. The back and forth voltage change is measured in hertz, one change or cycle per second being 1 Hz. In Australia, the AC electricity that we use at home has a voltage of 240 V and moves back and forth 50 times every second or 50 Hz.

7.1 QUESTIONS

Remembering

- 1 List the four parts of a simple circuit.
- 2 State the units for voltage, current and resistance.
- 3 List three examples of a load that could be included in a circuit.
- 4 State Ohm's law in both words and symbols.

Understanding

- 5 Clarify what is meant by a 'circuit'.
- 6 Define the terms:
 - a voltage
 - b current
 - c resistance
- 7 Draw a diagram to **outline** how components in a circuit are connected:
 - a in series
 - b in parallel
- 8 Explain what an electrical appliance marked with 240 V, 50 Hz means.
- 9 A series circuit and a parallel circuit each have two globes in them. Describe what would happen in each if one of the globes was to blow.

Applying

- 10 Use the key in Figure 7.1.5 on page 258 to determine the resistance of the resistors in Figure 7.1.16.

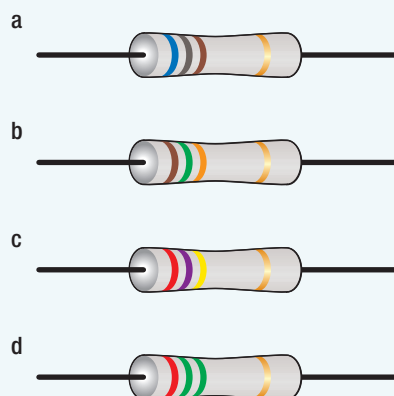

Fig 7.1.16

- 11 Use the same key on page 258 to determine the order of colours of the first three bands for each of the following resistors:
 - a 560 Ω
 - b 3300 Ω
 - c 470 000 Ω
 - d 1 200 000 Ω
- 12 Draw diagrams to **demonstrate** all of the components in both the water pump and electric circuits. Label each component.
- 13 Sketch a graph to **demonstrate** Ohm's Law, showing the relationship between voltage, current and resistance in Ohm's law.
- 14 Identify whether AC or DC electricity is being used:
 - a in the washing machine
 - b in a torch
 - c in an iPod
 - d your bedroom light

- 15 Use Ohm's law to **calculate** the missing values in the table. **N**

Current (amps)	Voltage (volts)	Resistance (ohms)
8	15	
5		6
	240	18
10	240	
0.5		14
	12	1.5

- 16 A circuit has a 12 volt battery connected to a 50 ohm resistor. **Calculate** the current in the circuit. **N**
- 17 Ming constructed a series circuit with a 75 ohm resistor. She connected the circuit to an 8 volt battery.
- Draw a diagram to **demonstrate** the circuit.
 - Calculate** the current in the circuit. **N**

Analysing

- 18 Complete the following table to **compare** an electrical circuit with a water pump circuit.

Electrical circuit	Water pump circuit
Battery	
	Pipe
Voltage or energy	
Switch	
	Water flowing through pipe
	Waterwheel

- 19 A series circuit and a parallel circuit were set up, each with two globes. **Compare** the brightness of the globes in each case.

- 20 **Contrast** direct current with alternating current.

Evaluating

- 21 **Propose** reasons why the lights in a home are wired in a parallel circuit.
- 22 Another way of labelling a 3800 Ω resistor is 3K8. **Predict** the size of a resistor of resistance:
- 4K9
 - 2M5

Creating

- 23 **Construct** diagrams for the following circuits:
- two lights and a switch in series
 - two lights in parallel and a switch to turn both lights off at once
 - three lights in parallel, each of which can be turned off individually
 - two lights in series, parallel to a single light. One switch should turn off all lights at once, and another switch should turn off the single light only

Science Clip

A major blackout

On 14 August 2003, an electrical failure suddenly hit the United States and Canada. About 50 million people in cities from New York to Toronto had no power. People were trapped in subway trains and elevators for hours. The financial loss related to the blackout was estimated at \$6 billion. One month later, Italy's 57 million people were also affected by a blackout. Luckily it occurred on a weekend so its initial impact was less dramatic and caused less economic damage. Some developing countries have regular 'brownouts' because their need for electricity exceeds their ability to generate it. Electricity supply must be 'rationed', and so suburbs and towns have times each day when no electricity is available.

7.1 INVESTIGATING

Investigate the interactive program known as 'Crocodile Clips' (or any similar program) to construct circuits that can be used in different situations. Use the program to 'build':

- a doorbell that can make a buzzer operate
- a doorbell for the hearing impaired that has a light as well as a buzzer
- a circuit for a light that can be switched on or off at the top or bottom of stairs
- a circuit for a refrigerator door to turn the light on and off
- light circuits for home.

7.1 PRACTICAL ACTIVITIES

1 Simple series and parallel circuits

Aim

To compare the brightness of globes in series and parallel circuits

Equipment

- three globes
- connecting wires
- switch
- power pack

Method

- 1 Connect a series circuit containing one globe and observe its brightness.
- 2 Modify the circuit by inserting a second globe and then a third globe in series. Note the brightness of each globe.

- 3 Investigate the effect of removing each globe, one at a time, by gently unscrewing them a little.
- 4 Repeat all the steps but use a parallel circuit instead.

Questions

- 1 **Draw** circuit diagrams to demonstrate the three series and parallel circuits.
- 2 **Construct** a table showing the number of globes and brightness in each.
- 3 **Compare** the brightness of globes in series with that of a single globe.
- 4 **Compare** the brightness of globes in parallel with that of a single globe.
- 5 **State** the effect of removing a globe when they are:
 - a in series
 - b in parallel

2 Measuring voltage and current in circuits

Aim

To compare current and voltage in series and parallel circuits

Equipment

- three globes
- connecting wires
- switch
- power pack
- ammeter
- voltmeter



Safety

Before completing this activity you need to know how to correctly connect a voltmeter and ammeter into a circuit. Incorrect connection of meters can damage them. Check with your teacher before starting the activity.

Method

- 1 For each of the circuits listed below:
 - a use an ammeter to measure the current on each side of the battery, and in each branch of the circuit (or between each globe in the series circuits)
 - b use a voltmeter to measure the potential difference across each globe, and across the battery
 - c draw each circuit and record your results on the circuit as you go—
 - Circuit 1: a single globe in series
 - Circuit 2: two globes in series
 - Circuit 3: three globes in series
 - Circuit 4: two globes in parallel
 - Circuit 5: three globes in parallel

Questions

- 1 **Describe** how the current changes in different parts of:
 - a a series circuit
 - b a parallel circuit
- 2 **Describe** how the voltage is split between globes in a series circuit.
- 3 **Compare** the voltages of globes in a parallel circuit.

3 Ohm's law

Aim

To investigate Ohm's law

Equipment

- two resistors of known (but different) resistance value
- connecting wires
- switch
- 12 V power pack
- ammeter
- voltmeter

Method

- 1 Assemble the circuit shown in Figure 7.1.17.
- 2 Set the power pack to 4 V, close the switch and record the current displayed on the ammeter and voltage on the voltmeter.
- 3 Repeat step 2 but increase the voltage by 2 V.
- 4 Continue to increase the voltage in 2 V steps up to 12 V. Record the current and voltage readings.
- 5 Enter the results in a table like the one below and use Ohm's law to calculate the resistance at each voltage setting.
- 6 Repeat steps 2 to 5 using the other resistor.
- 7 Calculate the average resistance for each resistor. **N**
- 8 Construct a graph of voltage versus current for each resistor on the same set of axes.
- 9 Calculate the slope of the graph for each resistor. The slope of the graph is the resistance value. Compare this to the known values of the resistors. **N**

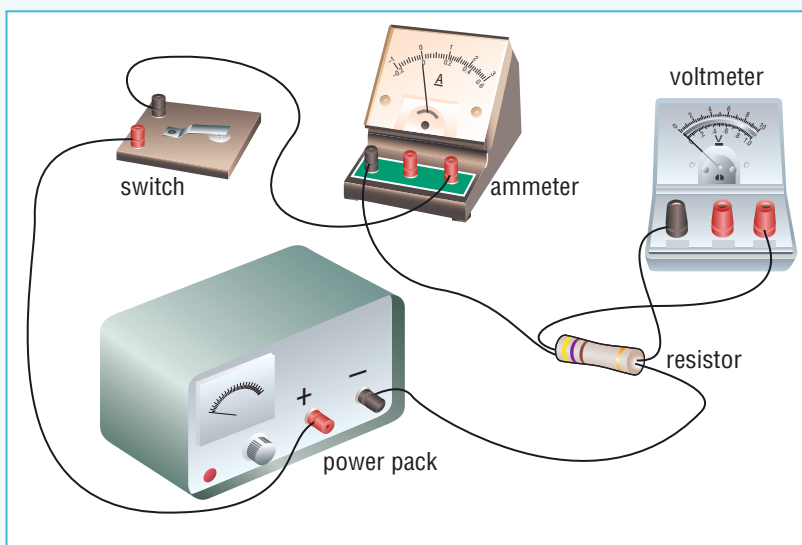

Fig 7.1.17

Questions

- 1 **Compare** the average resistance calculated using Ohm's law with the actual resistance from the slope of the graph. Suggest reasons for any differences.
- 2 **Describe** the shape of the graphs and use it to **predict** what would occur if:
 - a the voltage was doubled
 - b the resistance was doubled

Voltage (v)	Resistor 1		Resistor 2	
	Current (A)	Resistance (ohm)	Current (A)	Resistance (ohm)
4				
6				
8				
10				
12				

context

Magnets are the basis of compasses and are used to hold notes on the fridge and to keep cupboard doors shut. There is

also an important connection between electricity and magnets: electricity can make magnetic fields and magnetic fields can make electricity! This connection is responsible for most of the appliances we use—everything from speakers to televisions, trains to vending machines.



Fig 7.2.1 A Maglev train on trial in Germany. Maglev trains use electromagnetism to repel themselves off the track so that they float above it. Electromagnetism also moves the train forward. Other Maglev trains are currently being tested in Japan.

Magnetic fields

Invisible force-fields called **magnetic fields** exist around permanent magnets and around the Earth. A magnetic field is commonly shown as **field lines**, pointing from the North Pole to the South Pole of the magnet. When two magnets are brought near one another, they experience a force due to the interaction of both their fields. This force could be attractive (between North and South poles) or repulsive (either between North and North poles or South and South poles).

A **compass** is simply a tiny, suspended magnet that aligns itself with the field lines of any magnetic field nearby. The North Pole end of the compass needle swivels to point along the field lines towards the nearby South Pole. Its South Pole end is attracted by the North Pole, following the magnetic field lines.

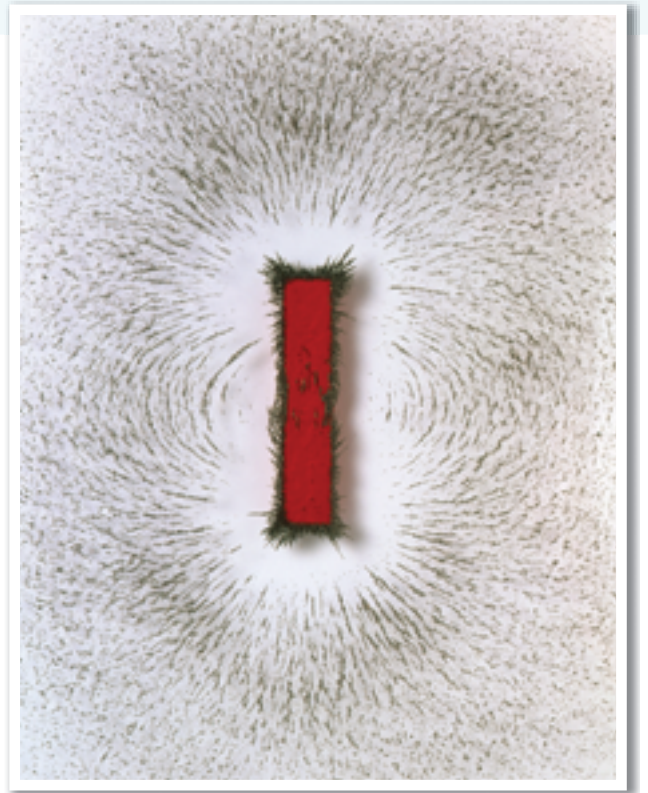

Fig 7.2.2 A magnetic field exists around a bar magnet. Iron filings and compasses align themselves with the field.

Magnetic fields around a wire

Magnetic fields also exist around wires that carry an electric current. The magnetic field produced forms a series of concentric circular rings, with the current-carrying wire in their centre. The field gets weaker further away from the wire.

If the wire is looped, the magnetic field produces a stronger field down the centre of the loop. If a wire is coiled so that several loops are placed together, as in a **solenoid**, then the magnetic field is stronger again.

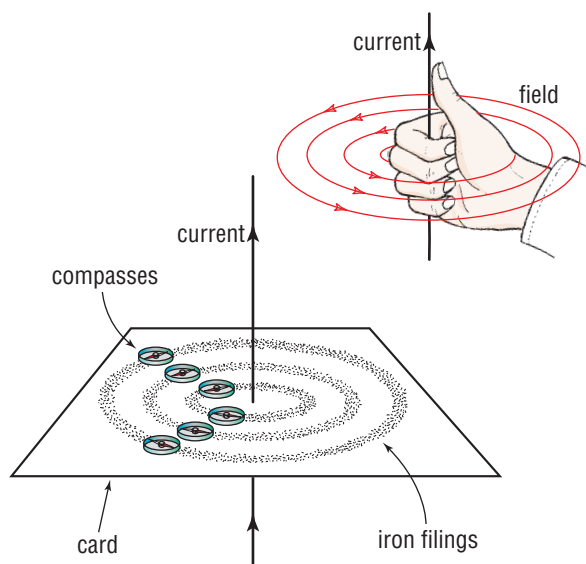

Fig 7.2.3 Wires that carry an electric current create their own magnetic field. Its direction is given by the right-hand rule. This is the direction in which a compass needle would point. When discussing electromagnetism, current is considered to be the direction in which positive charges flow.

Science Fact File

Accidental discovery

In 1820, Danish physics professor Hans Oersted was carrying out experiments with electric circuits when he noticed that the needle of a compass on his desk moved whenever an electric current flowed nearby. Oersted was able to move a compass needle without touching it, as if by magic. Oersted had discovered that electricity could cause magnetism.

Science Fact File

All back to front!

When the first experiments involving electric current were carried out, physicists decided that it was positive charges that flowed through their wires. Although we now know that it is the negative electrons that flow, physicists still refer to current as the flow of positive charges. This change in direction only causes problems when you want to use the right-hand rule. That is when you must think of current as the flow of positive charges, flowing in a direction opposite to that of the electrons.

Electromagnets

An **electromagnet** is a solenoid with an iron core that further concentrates the field down its centre. Unlike permanent magnets, electromagnets can easily be switched on and off. Their strength can also be altered, simply by changing the current that flows through them. This makes them incredibly useful. Electromagnets are the basis of door latches, door bells, speakers and head phones and much, much more. They range in size from huge industrial electromagnets to the tiny ones found in the speaker and microphone of your mobile phone.

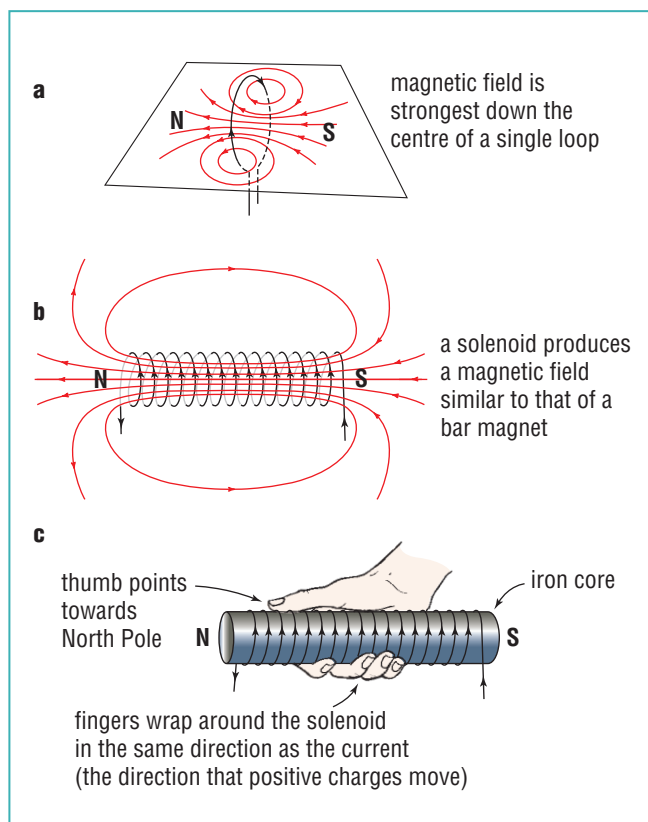

Fig 7.2.4 A solenoid is the basis of an electromagnet. The right-hand rule can be used to predict the direction of the magnetic field. Once again, the current is considered to be the flow of positive charges.



Fig 7.2.5 Electromagnets can be turned on and off and are generally stronger than permanent magnets. This makes them very useful in industry and in everyday electrical appliances.

Using electromagnets

Cardboard or fabric speaker cone: changing interactions cause the cone to vibrate. This vibrates the particles in the air to create sound waves that will eventually be heard.

Input: varying electrical current comes from radio, TV or music.

Solenoid: current creates a magnetic field through its core.

Permanent magnet: the permanent magnetic field interacts with field of solenoid. They attract when the current flows one way and repel when the current reverses direction.

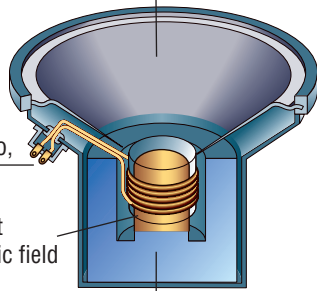

Fig 7.2.6 Radio, TV and music systems all rely on speakers to transmit sound to their listeners. There are small speakers in mobile phones and answering machines and even smaller speakers in headphones.

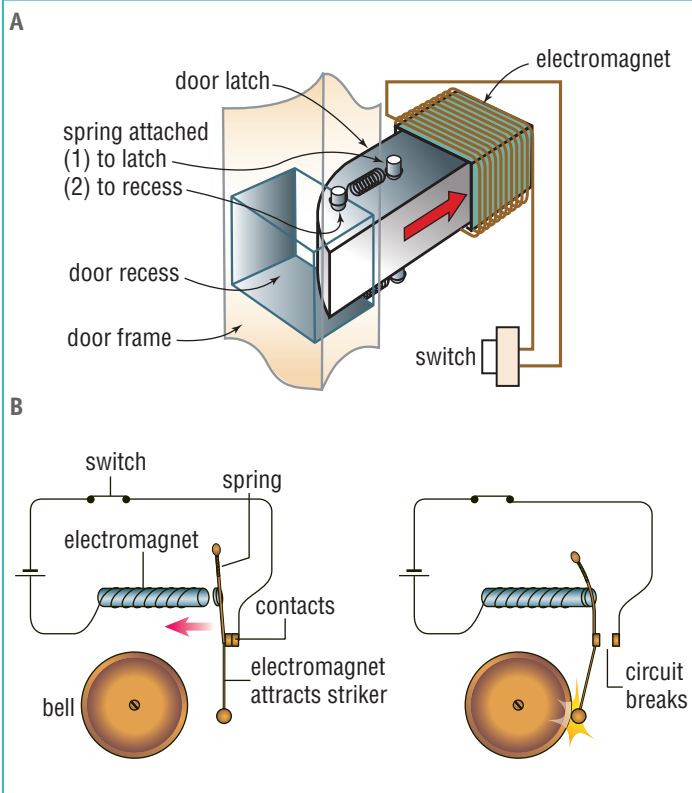

Fig 7.2.7 A An electromagnetically operated door latch—to open a door, a button is pressed, resulting in a current flowing to a coil. The resulting magnetic field attracts the latch out of the door recess, opening the door. **B** A door bell—pressing the switch on an electric bell completes the circuit, allowing a current to flow into the magnet. The magnet attracts the striker which hits the bell. The circuit breaks, turning off the electromagnet, releasing the striker. This repeats over and over.

Science Clip

Superconductors

When metals like tin and lead are cooled to -270°C they lose all electrical resistance, and so allow large currents to flow with little loss of energy. But there is a problem—it costs a lot to cool metals this far. A more recent development are the so-called ‘high-temperature’ superconductors made of ceramic material such as yttrium barium copper oxide. Ceramics like this need to be cooled to ‘only’ -200°C , a huge saving compared to previous superconductors. Applications of high-temperature superconductors include Maglev trains and devices that can detect tiny magnetic fields such as those produced by the brain.

Trains

Japan’s experimental Maglev (short for magnetic levitation) train uses superconducting electromagnets to lift it 10 centimetres above the track, position it correctly and propel it at speeds of over 500 kilometres per hour. Such high speeds are possible because of the train’s streamlined shape, and the lack of friction between the train and track.

Worksheet 7.2 Inside MLX01

Currents in a magnetic field

A wire that carries an electric current creates its own magnetic field. When placed in the field of another magnet, the two fields interact and so the wire experiences a force. The wire will move if free to do so.

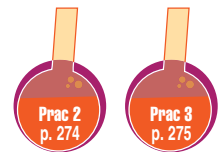

Right hand

The right fingers should be pointed in the direction of the field of whatever magnet is nearby.

The force on the wire comes directly out of the palm. The force acts as if it is slapping the wire in that direction.

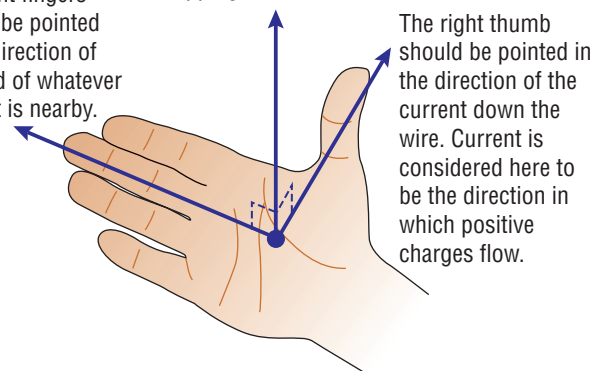

Fig 7.2.8 The right-hand slap rule allows the direction of the force on a current-carrying wire to be predicted. The force is at its maximum when the wire is at right angles to the field and zero if the wire is parallel to it.

TV and computer monitors

The bulging tube at the back of a 'normal' (non-plasma or LCD) television or computer monitor is an electron gun, shooting electrons at the back of the screen. Although not trapped in a wire, these electrons still make up an electric current that can be shifted around by a magnetic field. On the screen is a pattern of tiny pixels made from red, green and blue spots or rectangles. These pixels illuminate when struck by an electron and electromagnets control which pixels are hit. LCD and plasma screens also have pixels, although they are activated in a different way.

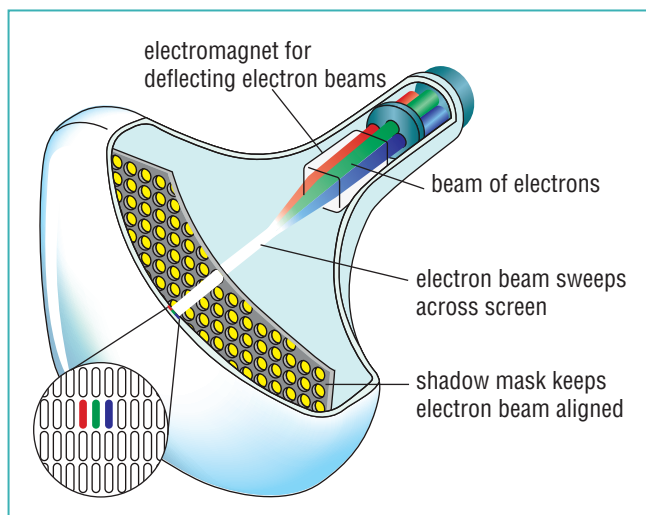

Fig 7.2.9 Electromagnets guide the electron beams to the right spot on a TV screen. The electron beams in a TV are not coloured. They are coloured here to indicate that there is one beam for each colour pixel in a section of screen.

Go to Science Focus 3 Unit 7.3

Electric motors

An electric motor uses the interaction of an electric current and a magnetic field to convert electrical energy into movement and kinetic energy. This causes the motor to spin. Motors are in most devices that have moving parts, such as CD and DVD players, hairdryers, slot cars, windscreen wipers, washing machines and electric toothbrushes.

Science Clip

Magnets and coils

In 1831, the English scientist Michael Faraday created the first simple electrical generator by continually moving a magnet in and out of a coil. Because the magnet kept on changing directions, the current produced was changing directions too.

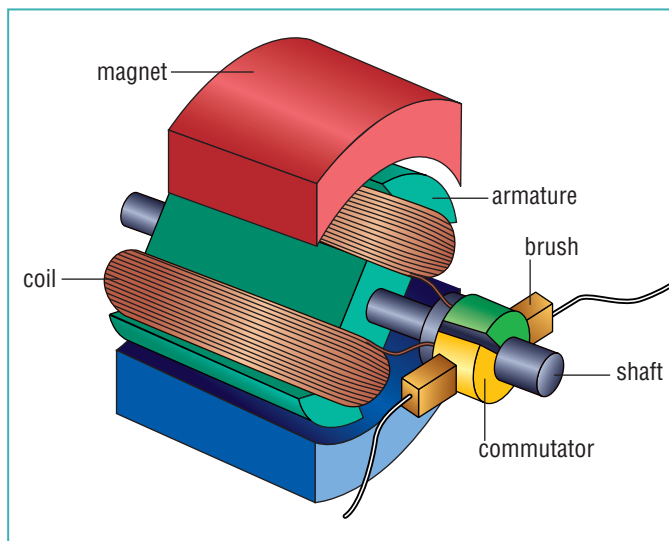

Fig 7.2.10 Inside a simple electric motor

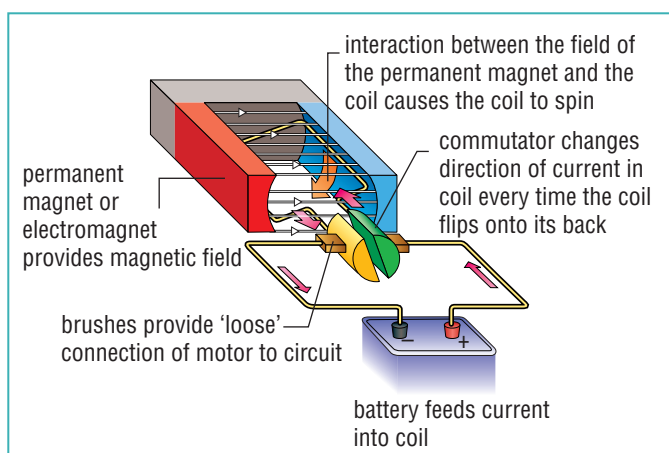

Fig 7.2.11 An electric motor works because of the interaction between the magnetic fields of a magnet and the coils that carried electric current.

Electric generators

An electric current produces a magnetic field. The reverse can also happen: a magnetic field can produce an electric current.

An electric current is produced whenever a magnet and a coil of wire are moved relative to each other. If the magnet is stopped, then so does the current. If the magnet changes direction, then so does the current being produced. This is the basis of a simple **generator**, a device that produces electric current.

Apart from battery-powered devices, most of the electricity we use is AC and comes from electrical generators. These can be small (as on a bike) or huge, feeding the power grid of a city.



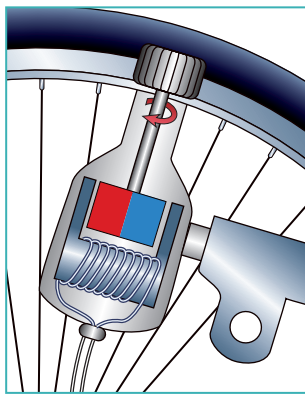

Fig 7.2.12 A bicycle dynamo

Dynamos

Bikes often have a small AC electric generator called a **dynamo** attached to their wheel rim. A rotating magnet inside the dynamo produces alternating current similar to that produced by moving a magnet in and out of a coil.

Turbines

Dynamos do not generate enough power for a city. Instead, massive turbines are spun by water or steam. The principle is the same though: the turbines are attached to magnets that then spin in a coil to produce AC electricity.

Other uses of generators

The creation of current by a changing magnetic field can be used for purposes other than generating power. Microphones, for example, generate a current that is then transmitted to an amplifier or some recording device.



Fig 7.2.13 Compare the size of the person in this photo with the steam-driven turbine used to generate electricity.

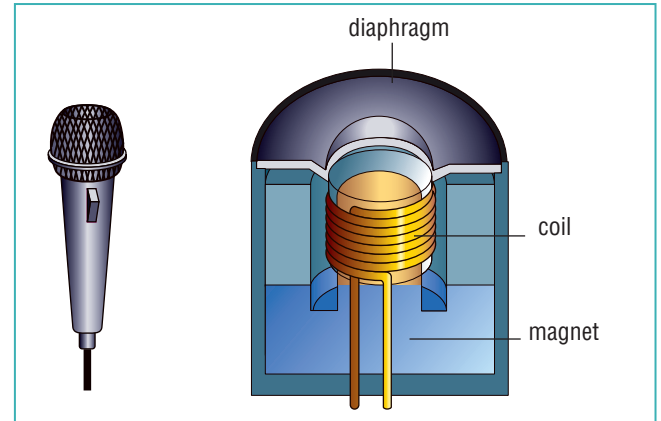

Fig 7.2.15 A moving-coil type microphone contains a diaphragm which vibrates a coil in response to sound waves, generating a current that varies with the strength and frequency of the vibrations.

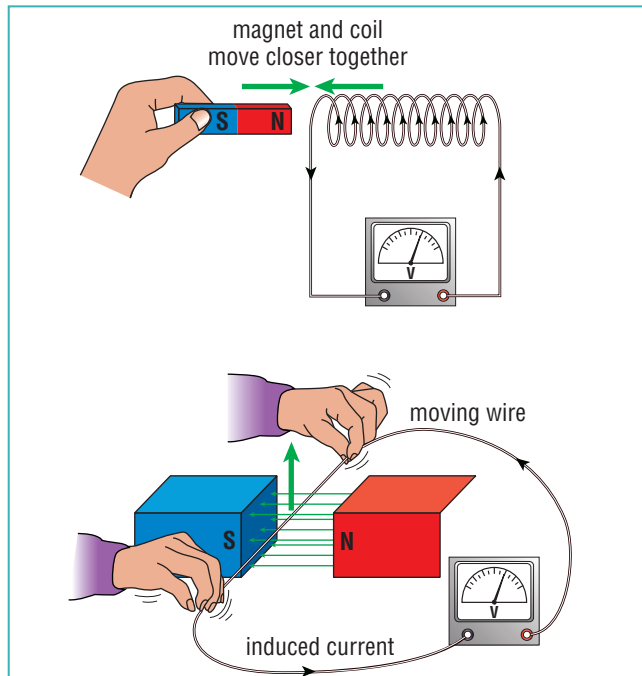

Fig 7.2.14 A current is produced if the coil of wire moves relative to the magnetic field.

Vending machines

It's not just coils that have currents induced in them by magnetic fields. A solid coin passing through an electromagnet in a vending machine creates swirling currents within it. These currents in turn create

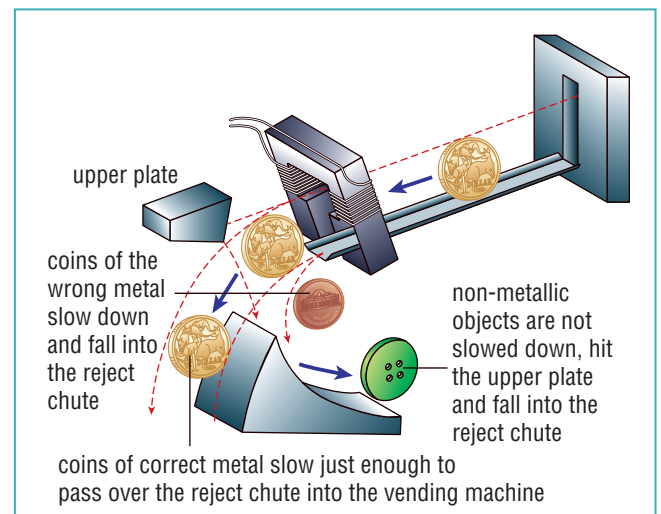

Fig 7.2.16 The operation of a vending machine

magnetic fields, and interact with the electromagnet to slow the coin down. Coins that are not the correct weight or made from a non-metal are not slowed the right amount, and are rejected.

Transformers

Sometimes the voltage provided is either too large or too small for the intended use. For example, laptop computers only need 16 V and mobile phones need only 5.7 V to recharge. The 240 V available from the power point would damage both if used directly. For efficiency reasons, the best voltage for long-distance transmission of electricity is between 220 000 and 500 000 V, whereas the electricity is generated at a much lower voltage. In all these cases a **transformer** is needed.

Transformers use solenoids and the magnetic fields they produce to either increase (step up) voltage or reduce (step down) voltage to the value required.

Power transmission

Power stations use energy from burning coal, flowing water or other sources to spin turbines in large generators, and transmit power through an extensive network of overhead and underground power lines.

Because high-voltage transmission is more efficient, a transformer is needed close to the power station. These high voltages would be far too dangerous, however, if fed directly into your suburb or home, and so a series of transformers is used to reduce the voltage to the final (but still deadly) 240 V we use.

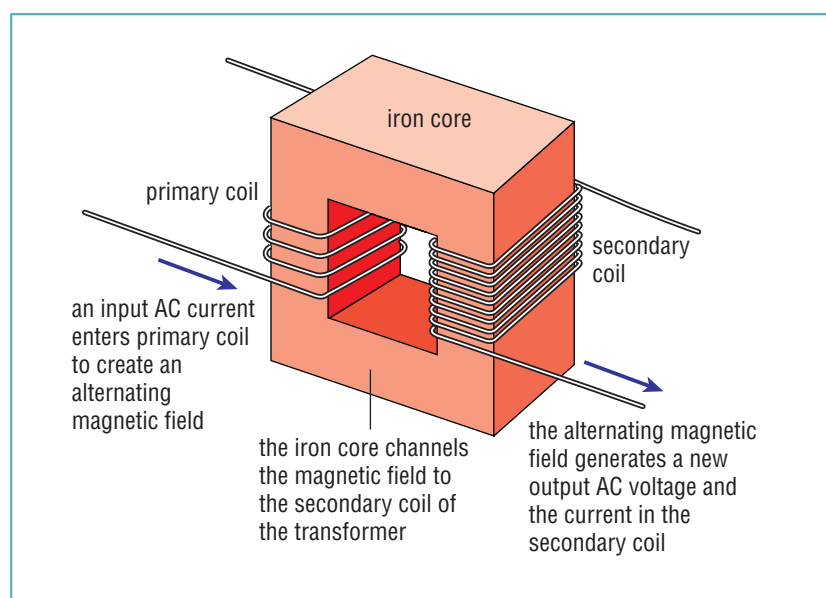

Science Clip

Traffic light magic

How do traffic lights 'know' there is a car waiting at them? Pads under the road have a coil in them that carries a current. The electromagnetic field it produces induces a current in the car, which in turn interferes with the current in the road. When this interference is detected, the lights 'know' that they should change to let the car through.

Fig 7.2.17 Transformers use electromagnetism to step up or step down voltages. This is a step-up transformer.

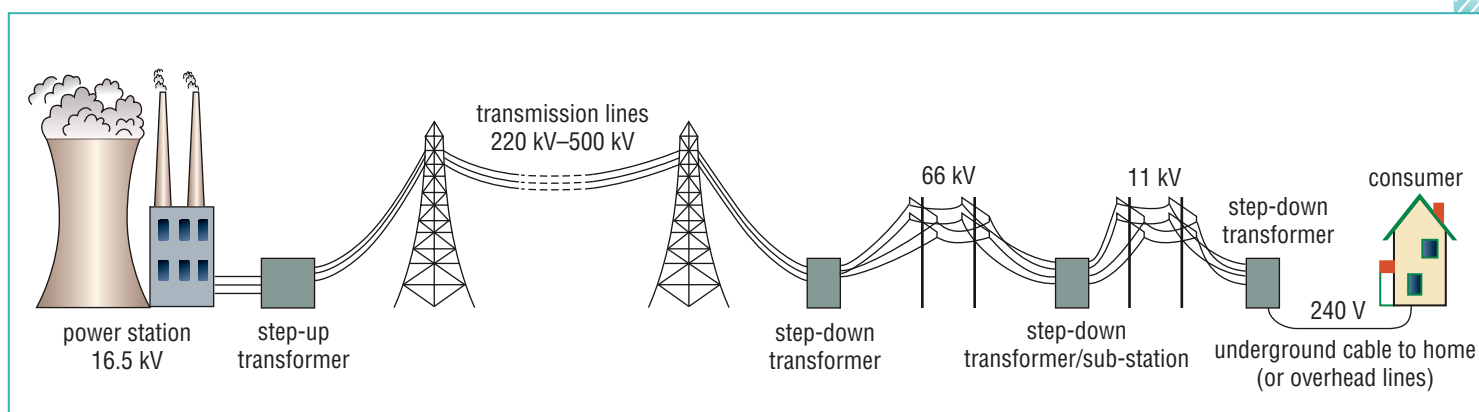

Fig 7.2.18 How electricity reaches our homes from the power station

7.2 QUESTIONS

Remembering

- 1 **State** the year when Oersted discovered that a current produced a magnetic field.
- 2 **State** the key advantage of an electromagnet over a conventional magnet.
- 3 **a List** three devices that use electromagnets.
b State the job done by the electromagnet in each case.
- 4 **List** two devices that contain a simple generator.
- 5 **State** what a transformer is used for.
- 6 Use Figure 7.2.18 to **list** the main stages in electricity transmission.
- 7 **State** what type of transformer (step-up or step-down) would be needed:
 - a for a laptop computer
 - b for long-distance transmission
 - c at a substation on the outskirts of a town
 - d to recharge a mobile phone

Understanding

- 8 **Outline** the difference between a solenoid and an electromagnet.
- 9 Use figure 7.2.14 to **outline** the result of:
 - a placing the magnet in the coil of wire
 - b removing the magnet from the coil of wire
 - c continually moving the magnet in and out of the coil of wire
- 10 **Use** an example to explain how an electromagnetic device operates.
- 11 **Explain** how a soft drink machine 'knows' when an incorrect coin has been inserted.
- 12 **Explain** why power companies bother increasing the voltage of power lines if it is only going to be reduced again before reaching homes.

Applying

- 13 **Identify** whether the following situations would generate an electric current:
 - a a magnet enters a wire coil
 - b a magnet sits still inside a wire coil
 - c a magnet is removed from a wire coil
 - d a wire coil moves towards a magnet
 - e a wire coil moves away from a magnet
 - f a current is turned on in a wire coil facing another wire coil

Analysing

- 14 **Compare** the voltages of transmission lines with that used at home.
- 15 **a** Count the number of primary and secondary coils in the transformer shown in Figure 7.2.17.
b Classify it as a step-up or step-down transformer.
- 16 **Propose** a reason why high-voltage power lines are always kept well above the ground by tall pylons.

Creating

- 17 **Construct** a diagram showing the shape of the magnetic field around a straight wire.
- 18 **Design** and sketch a circuit that uses electromagnets to release a trapdoor when a person steps on a certain section of floor.

7.2 INVESTIGATING

Investigate your available resources (for example, textbooks, encyclopaedias, internet) to complete the following tasks.

- 1 Research how electromagnetism is used to record and erase magnetic audio or videotapes. Use a diagram to explain your information.
- 2 Research some of the discoveries made by Joseph Henry (1797–1878) in the area of electromagnetism and give a one-minute oral presentation on one discovery. Use props to assist you in your explanation.
- 3 Use an example to explain how another rule, 'Fleming's left-hand rule', gives the direction of the force on a current in a magnetic field.

- 4 a Research whether it is dangerous to live near high-voltage power lines.
- b Write a letter to the government outlining the potential dangers of electromagnetic radiation. Be sure to support your ideas with evidence.
- c In your letter, recommend what should be done to reduce the risk of electromagnetic radiation to the community.
- d Conduct a class debate on this issue.

e-xploring



To find out more about electromagnetism and Japan's Maglev train, a list of web destinations can be found on **Science Focus 4 Second Edition Student Lounge**. Select one example of a device that uses electromagnetism and present your information in the form of an advertisement.

7.2 PRACTICAL ACTIVITIES

1

Oersted's experiment and the electromagnet

Aim

To investigate the magnetic field around a current-carrying wire

Equipment

- power supply
- switch
- insulated copper wire (1 m)
- tape
- switch
- small compass
- cardboard tube
- large iron nail

Method

- 1 Assemble the apparatus as shown in Figure 7.2.19. Ensure the power supply is set to 2 volts.
- 2 Hold the switch down and note any effect on the compass needle.

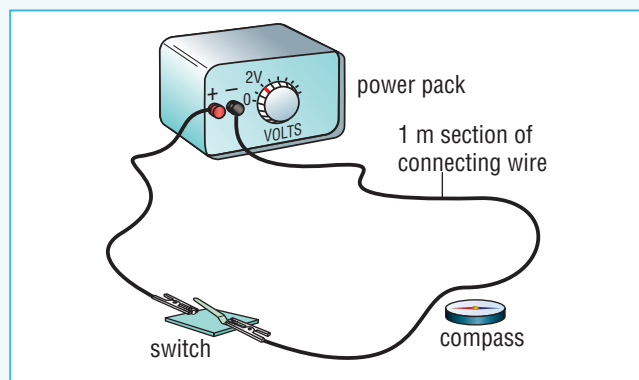

Fig 7.2.19

- 3 Investigate the effect of moving the compass further away from the wire.
- 4 What happens if the voltage is turned down (and the current reduces)?
- 5 Now wind the wire around the cardboard tube as shown in Figure 7.2.20 on page 274. Use tape to secure the coils to the tube.
- 6 Compare the strength of the magnetic field inside the tube with that produced in step 2.
- 7 Now wind the wire around the nail instead of the cardboard tube. Use tape to secure the coils if required.

>>

- 8 Hold the pointed end near the compass while holding the switch down.
- 9 Hold the head of the nail (the non-pointy end) near the compass while holding the switch down.

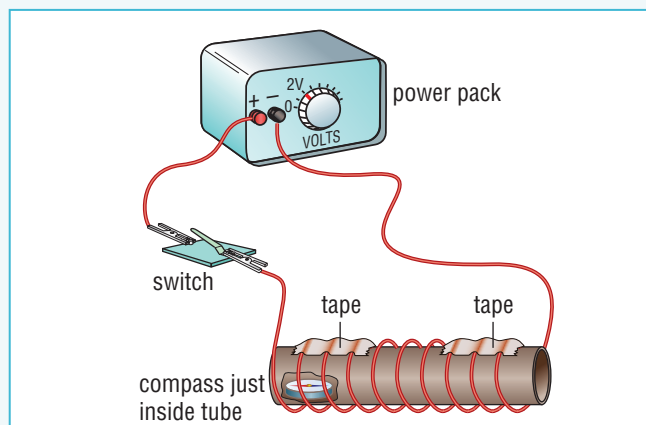

Fig 7.2.20

Questions

- 1 **Explain** what happens to the strength of a magnetic field as you move further from a wire.
- 2 **Explain** whether a larger current produces a stronger or weaker magnetic field.
- 3 Would several coils cancel each other's magnetic fields or reinforce them? **Justify** your answer.
- 4 **Explain** whether an electromagnet is stronger or weaker with an iron core.
- 5 **Describe** how the magnetic fields differ at each end of the nail.

2 Force on a wire

Equipment

- small sheet of cardboard
- scissors
- sticky tape
- aluminium foil
- retort stand
- bosshead and clamps
- wires with alligator clips
- switch
- power pack with circuit breaker/auto cutoff
- horseshoe magnet

Method

- 1 Cut a 'picture frame' out of the cardboard and stick a single thin strip of aluminium foil across it.
- 2 Construct the apparatus as shown in Figure 7.2.21 and set the power pack at its lowest voltage.
- 3 Hold the horseshoe magnet as shown and quickly close then open the switch. (Note: the power pack might 'trip' and you will need to wait until it resets before attempting the rest of the Prac.)
- 4 Note which direction (if any) the strip of aluminium foil flexes.
- 5 Reverse the terminals on the power pack and repeat.
- 6 Reverse the orientation of the magnet (i.e. swap poles) and repeat.

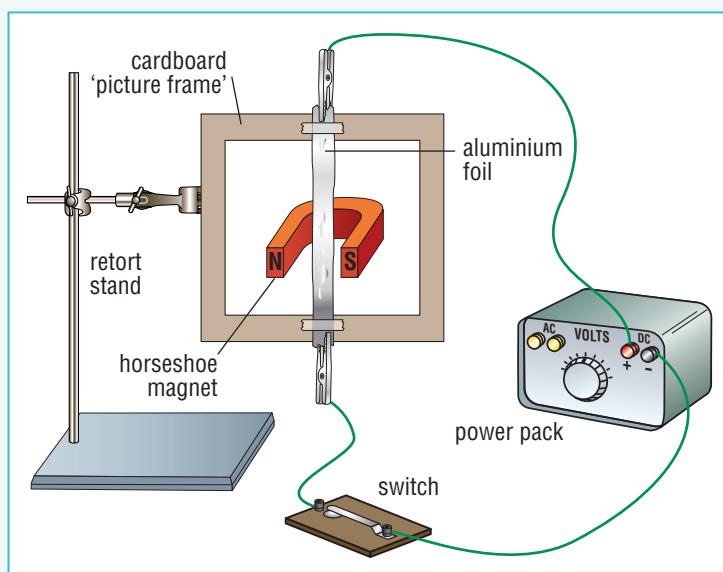

Fig 7.2.21

Questions

- 1 **Copy** the right-hand rule diagram on page 261.
- 2 **Use** the right-hand rule to check on the directions that the aluminium foil flexed in each part of the experiment.
- 3 **Write** a conclusion for the experiment.

3 A simple electric motor

Aim

To construct a simple electric motor

Equipment

- 1.5 volt battery ('D' size)
- Blu-Tack
- 2 rubber bands
- 2 paperclips
- 1.5 metres of enamelled copper wire
- a small but strong disc magnet or a bar magnet
- emery paper
- pliers (optional)

Method

- 1 Wind the enamelled copper wire around the battery to make a solenoid.
- 2 Remove the wire from the battery and straighten 5 cm or so at each end.
- 3 Wind a centimetre or two of the ends around the loops of wire to keep them together.
- 4 Using emery paper, scrape the underside of each straight end to expose the copper (see magnified view of straight ends in Figure 7.2.22).
- 5 Use fingers or pliers to shape the two paperclips as shown.
- 6 Use the rubber bands to attach the paperclips to the battery.
- 7 Place the magnet so it sticks to the top of the battery (see Figure 7.2.22). Alternatively, hold a bar magnet near the coil.
- 8 Stabilise the battery using Blu-Tack.
- 9 Add the loops to complete the motor and check that measurements and positioning match the figure.



- 10 Give the loops a nudge (you may need to try spinning the coil both ways) to start the motor. You may need to experiment with the position of the magnet.

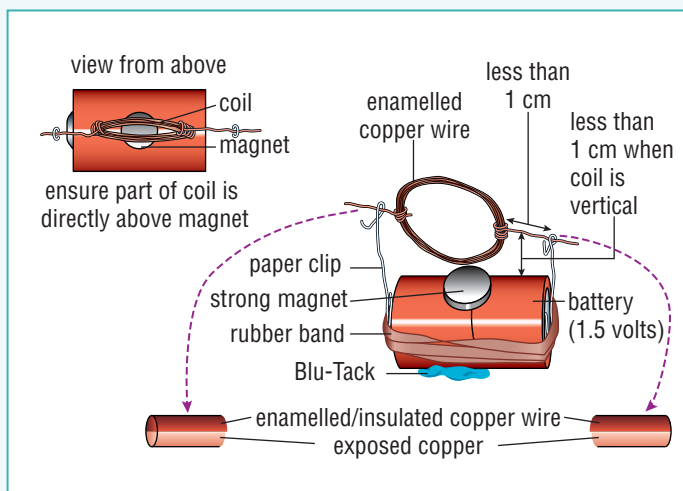

Fig 7.2.22

Questions

- 1 **Explain** why several loops are better than a single one.
- 2 **Predict** what would happen if the entire wire (loops included) was not insulated.
- 3 **Explain** how scraping half the coating from the straight ends of the wire helps. Predict what might happen if you didn't do this.
- 4 **Identify** possible improvements to your model motor.
- 5 Take apart a small electric motor (e.g. from a broken toy) and **compare** the parts with your model.

4 A simple generator

Aim

To investigate the correlation between magnetism and current electricity

Equipment

- solenoid
- bar magnet
- connecting wires
- galvanometer or microammeter

Method

- 1 Connect the circuit as shown in Figure 7.2.23.
(Note: a galvanometer is like a very sensitive ammeter, and detects small currents. In each step below, observe the reading on the galvanometer as you carry out the step.)
- 2 Move the north end of the magnet into the solenoid.
- 3 Leave the magnet resting in the end of the solenoid for several seconds.
- 4 Withdraw the magnet from the solenoid.
- 5 Repeat steps 1 to 4, but move the magnet more quickly.
- 6 Repeat steps 1 to 5, but move the south end of the magnet into the solenoid.

Questions

- 1 **Explain** why a globe was not used to detect current.
- 2 **Explain** whether a magnet in a solenoid always produces a current.
- 3 **Describe** the effect of varying the speed of the magnet.
- 4 **Contrast** the effect of the magnet when it is withdrawn with its effect when it enters the solenoid.
- 5 **Describe** whether changing the pole (north or south) that approaches the solenoid has an effect.
- 6 **Predict** the effect a stronger magnet would have.

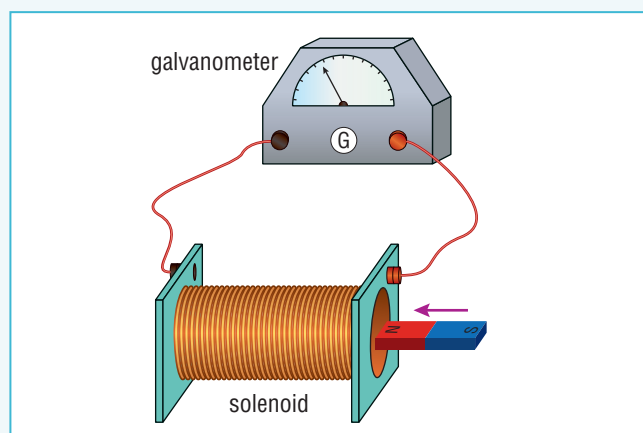

Fig 7.2.23

context

Visible light is only one small part of a wide range of waves known as the electromagnetic spectrum. While visible light allows us to see, other waves are detected in other ways. X-rays can pass through the body and produce images of our organs and bones. Infra-red radiation in sunlight warms our skin. TV, mobile

phones and radio detect electromagnetic radiations that form the basis of most modern communication. Electronic devices convert sounds, pictures and other information into waves which invisibly carry information from one place to another and are then turned back into information humans can see or hear.

Two kinds of waves

The main two types of waves are **transverse** and **longitudinal** (sometimes called **compression**) waves.

One of the special characteristics of waves is their ability to transfer energy from A to B without particles actually moving along the full route. When a transverse wave travels from A to B, the actual particles in the wave merely vibrate up and down. In a longitudinal wave the particles vibrate back and forth.

Think of a surfer on a board out past the surf or a boat floating in the ocean. Rather than moving along with the waves, both simply bob up and down on the spot.

If the coils of a slinky or the particles of water did move the full distance from A to B, they would all end up at B, leaving nothing at A—this clearly does not happen!



Fig 7.3.1 When an ocean wave reaches shallower water, friction from the sea bed slows the bottom of the wave more than the top. The result is that the top may break away, allowing some particles of water, possibly carrying a surfer, to move with the remains of the wave.



The particles in a transverse wave vibrate up and down, perpendicular to the wave. This is obvious in water waves: boats and seagulls simply bob up and down on them.

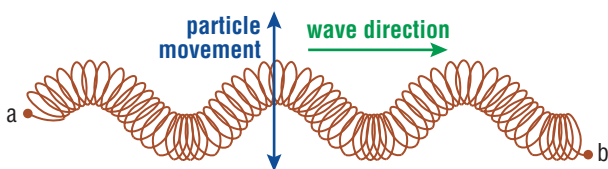

Fig 7.3.2 A transverse wave in a slinky. Water waves are transverse waves.

The particles in a longitudinal wave vibrate back and forth, parallel to the motion of a wave.

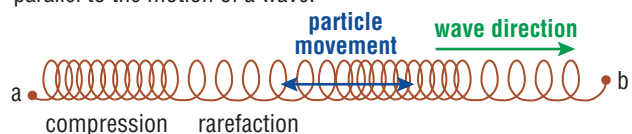

Fig 7.3.3 A longitudinal wave in a slinky. Sound waves are longitudinal waves.

Properties of waves

Imagine you are shaking a slinky back and forth to generate transverse waves at a steady rate. This rate is referred to as its **frequency**. If you are producing two waves every second, then the wave frequency is 2 waves per second or 2 **hertz**. This can be abbreviated as 2 Hz. The unit hertz is used to describe anything that has regular, repetitive behaviour. It means *per second*. For example, a wheel that rotates 10 times per second has a frequency of 10 hertz. Likewise, a sound wave that hits your eardrum with 200 compressions per second has a frequency of 200 hertz.

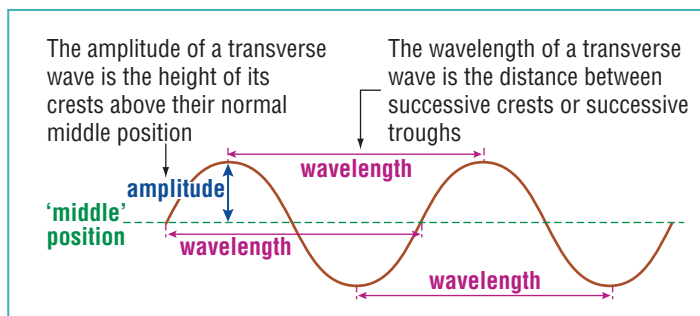

Fig 7.3.4 Amplitude and wavelength for a transverse wave

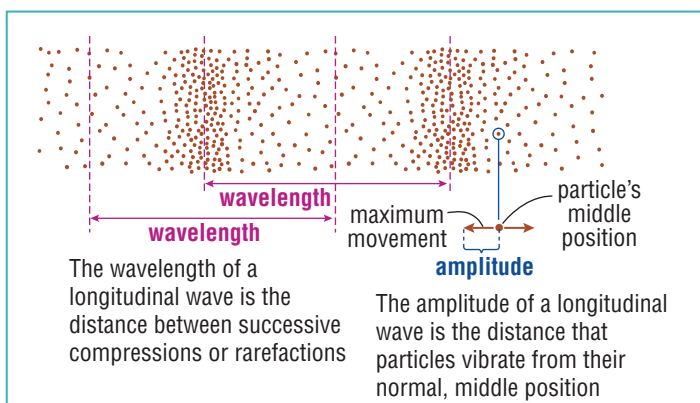

Fig 7.3.5 Amplitude and wavelength for a longitudinal wave

The distance between successive crests or successive troughs in a series of transverse waves is called the **wavelength**. The height of crests above their normal, middle position is called the **amplitude** of the wave. In a longitudinal wave, the wavelength is the distance between compressions (places where the particles are closest together) or rarefactions (places where the particles are farthest apart), and the amplitude is the distance that particles vibrate from their normal, middle position.

The **speed** a wave travels at depends on both its frequency and wavelength. This can be expressed mathematically as:

$$\text{speed} = \text{frequency} \times \text{wavelength}$$

In mathematical formulae, speed is given the symbol v while frequency has the symbol f and wavelength λ (the Greek letter *lambda*). This expression can therefore be written as:

$$v = f\lambda$$

Frequency is measured in hertz. Although wavelength can be measured in any length units, it is usually measured in metres. When these units are used, speed has the units metres per second (unit symbol m/s).

If, for example, a water wave has a frequency of 2 Hz and a wavelength of 1.5 metres then it is travelling at a speed of:

$$v = f\lambda = 2 \times 1.5 = 3.0 \text{ m/s}$$

Light waves

Water waves and sound waves transmit their energy because particles pass on their vibrations from one layer of particles to the next. Water molecules vibrate up and down as the wave passes through and molecules of gas (such as oxygen, nitrogen, water vapour) vibrate back and forth when sound passes through air.

Light is unusual in that it can transmit through a vacuum where there are no particles to vibrate and no particles to pass the energy along. Light can do this because it is a very different kind of wave. It is a wave that doesn't need particles to transmit its energy—it is an **electromagnetic wave**.

Light as an electromagnetic wave

An electromagnetic wave is made up from two interconnected waves travelling at right angles to each other. One wave is formed by a changing **magnetic field**, the other is formed by a changing **electric field**.



Science Clip

The invention of non-existent aether

Until about 1900, scientists were confused about light and how its waves travelled through the vacuum of space. They believed that all waves needed a material to travel through and so an imaginary material called luminiferous aether was 'invented' to 'fill' space. Although there was absolutely no evidence for aether, most scientists were convinced it existed—that is, until the Scottish physicist James Clerk Maxwell developed his idea of light as an electromagnetic wave which could travel through a vacuum.

Light consists of **electromagnetic waves** that travel at an incredible speed of 300 000 kilometres per second.

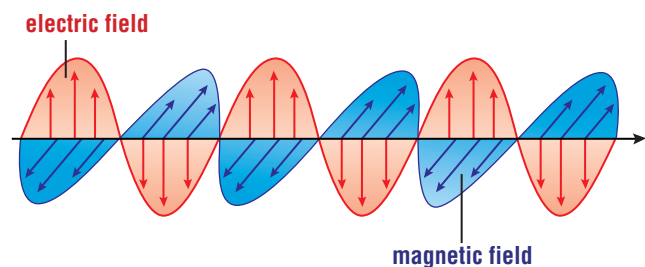

Fig 7.3.6 The magnetic and electric fields of light waves are perpendicular to each other.

The visible spectrum

The range of colours you are able to see is called the **visible spectrum**. White light is really a mixture of all the colours of the visible spectrum, and consists of waves of different wavelengths and frequencies all travelling at the same speed.

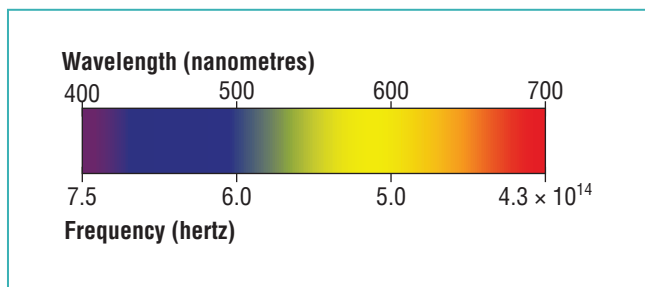

Fig 7.3.7 Whatever its colour, the wavelength of visible light is extremely small, being less than one thousandth of a millimetre. The human eye is more sensitive to some colours than to others.

Go to [Science Focus 3 Units 7.3, 8.1](#)

Science Clip

Spirit warning



Aboriginal people have traditionally used a device called a bull roarer, or kooladoo, to communicate using sound waves. The bull roarer is used to warn women and young children away from men's ceremonies, particularly during initiation. It is made from a flat piece of wood, about 30 centimetres in length and fastened at one end to a string. When swung around in the air it produces a whirring or howling sound likened to those of animals or spirits. The sound is regarded as the voice of a spirit that comes to take the young boys away. In some cases bull roarers were associated with various objects known as *churinga* which women or uninitiated men were forbidden to see. Penalties were severe—blinding by fire-stick or even death.

The electromagnetic spectrum

The visible spectrum is only a small part of a wide group of electromagnetic waves. In order from smallest to largest wavelength, these are: gamma rays, X-rays, ultraviolet rays, visible light, infra-red rays, microwaves and radio waves. These make up the **electromagnetic spectrum**. Though we cannot see these other types of waves, they can be detected and are used in a variety of applications.

Gamma rays

Gamma rays are extremely high-energy waves released in bursts from the nuclei of certain atoms including uranium and plutonium—hence they are a form of **nuclear energy**. Substances that release nuclear energy such as gamma rays are said to be **radioactive**. Gamma rays can be detected using photographic film or a Geiger counter, and can be used to destroy cancer cells, which are more sensitive to radiation than normal cells. Some normal cells are still killed, however, resulting in the unpleasant side-effects of radiotherapy.

Go to [Science Focus 4 Unit 1.3](#)

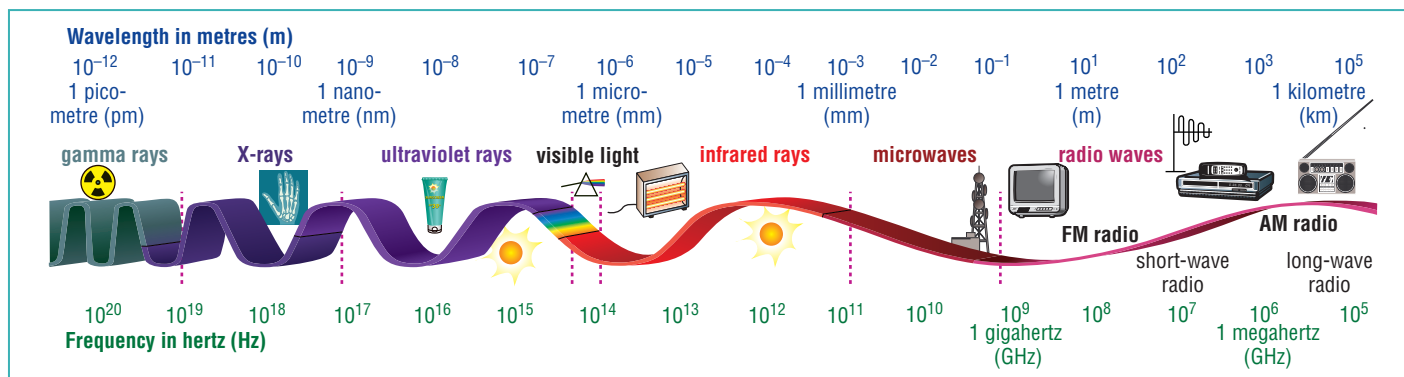

Fig 7.3.8 The electromagnetic spectrum—although wavelengths and frequency vary, speed is the same (300 000 000 metres per second) for all types of electromagnetic waves.



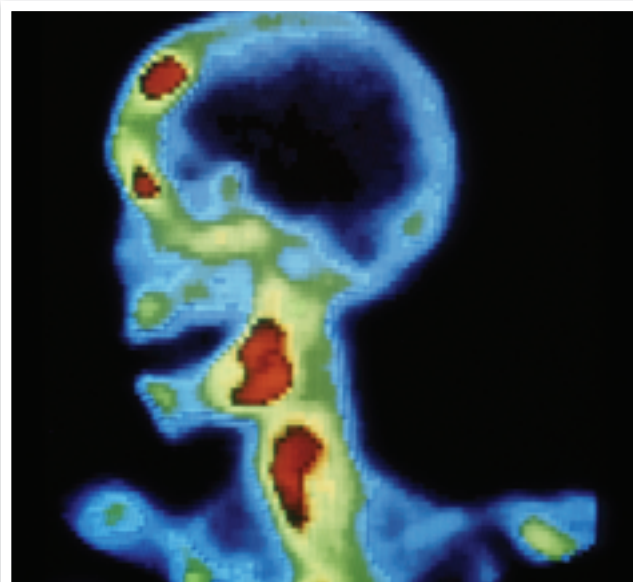

Fig 7.3.9 Gamma rays are used to produce scans like this one of a human skull. A radioactive isotope is injected into the blood vessels supplying the region, and tends to concentrate in tumours and cancerous bone, producing spots of 'hot' colours (red, orange) on the image. 'Cool' colours (violet, blue, green) indicate very little radioisotope and therefore healthy tissue.

X-rays

X-rays are produced when fast-moving electrons lose energy suddenly, for example, when smashing into a metal target. Short-wavelength X-rays can penetrate dense metals such as lead, while long-wavelength X-rays penetrate flesh but not bone, and so may be used to 'photograph' inside the body.



Fig 7.3.10 The term X-ray is used for both the electromagnetic waves and the image produced by them.

Science Clip

A handy discovery

In 1895, Wilhelm Konrad Roentgen was passing electrons through a gas in a device called a discharge tube when he noticed that a card coated with a barium salt nearby began to glow. He noticed that the card even glowed when he placed objects between it and the tube. When he placed his hand in the way he was amazed to see a 'shadow' of his hand bones on the card! Roentgen had discovered X-rays.

Ultraviolet radiation

Whenever the Sun shines on us, we receive both visible light and invisible ultraviolet ('ultra' means 'beyond') or **UV radiation**. A small amount of UV radiation is vital as it helps produce vitamin D. Too much, however, causes damage to the skin in the form of a suntan, sunburn or various skin cancers. Some washing powders contain special chemicals which absorb ultraviolet light and then re-emit it as visible light to give the impression of 'whiter-than-white' clothes. Ultraviolet light can be used to kill bacteria, and is used in hairdressing salons and air-conditioning systems.



Infra-red radiation

Infra-red (or IR) rays have a frequency below that of red light. They are often associated with heat and are released from vibrating atoms or molecules. All objects contain vibrating atoms and molecules, so all objects emit infra-red radiation. The hotter the object, the more the vibration, and so the more the energy released as infra-red radiation.

When high-energy waves are emitted they become visible as red light, and so the expression 'red hot'. Remote control devices emit infra-red waves which are detected by special components within televisions and sound systems. They are then converted to electrical energy to control functions such as volume and channels.

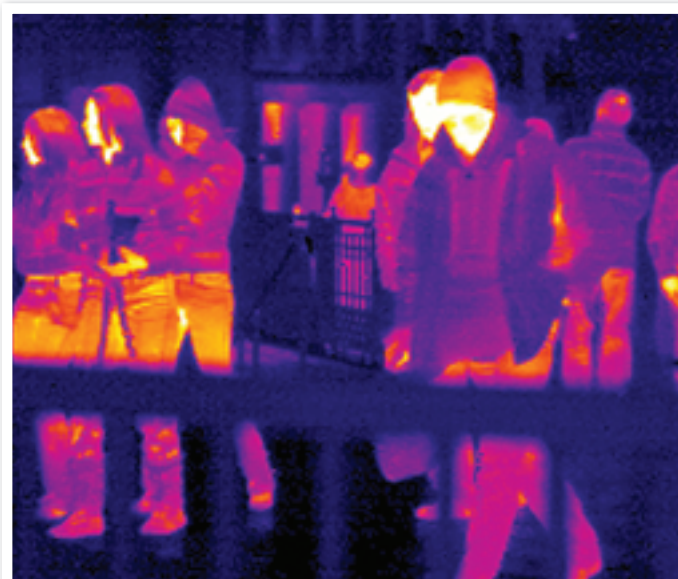

Fig 7.3.11 Objects emit invisible infra-red electromagnetic waves. The different colour in this image indicates the different temperatures of each object. White is the hottest while black is the coolest.

Microwaves

Sometimes called short-wave radio waves, **microwaves** are generated by vibrating electrons in electrical devices, and typically have a wavelength of a few centimetres. They are easy to direct, can pass through the Earth's ionosphere and are used in satellite communication, radar and mobile phones. Water molecules in food vibrate at the same frequency as microwaves. Food strongly absorbs microwaves, converting their energy into heat energy in a microwave oven.

Radio waves

Radio waves are also generated by vibrating or oscillating electrons and are used in radio and television broadcasting. Radio waves have wavelengths of hundreds of metres to tens of centimetres and are classified into several categories. Long radio waves are useful for communicating around the Earth, as they bend to follow

the Earth's surface (bending around objects like this is called **diffraction**). Short waves may also travel around the Earth, by reflecting from the ionosphere.

Go to  Science Focus 3 Unit 8.4

AM and FM

The terms AM and FM are often used when referring to radio stations. Electromagnetic waves such as radio waves can carry information (e.g. sound or vision) as changes or fluctuations in either frequency or amplitude. Receivers detect these changes and convert them back to sound or vision or some other form.

This information first must be converted into a wave, in a process called **modulation**.

Amplitude modulation, or **AM**, is the process in which information is carried as changes in wave amplitude. Similarly, **frequency modulation** or **FM** is the process in which information is carried as changes in wave frequency.

Radio stations transmit sound using both AM and FM, while television stations transmit sound using FM, and vision using AM. Australia's national broadcaster, the ABC, transmits AM carrier waves of frequency 774 kilohertz (1 kilohertz = 1000 hertz), which will be detected by a radio tuned to this frequency.

The higher frequencies of FM stations are less affected by interference, and provide a better quality sound than AM, though they have less range.

 **Worksheet 7.3** Electromagnetic spectrum

Science Clip

Marconi

Italian engineer Guglielmo Marconi is generally credited with inventing radio. In 1895 he transmitted a signal 2.4 kilometres while in the grounds of his father's property. He patented the first 'wireless telegraphy' system in 1896.

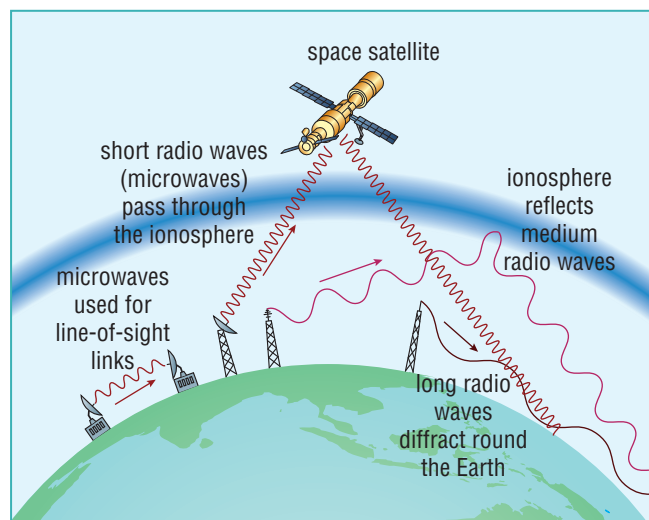

Fig 7.3.12 The behaviour of different types of radio waves

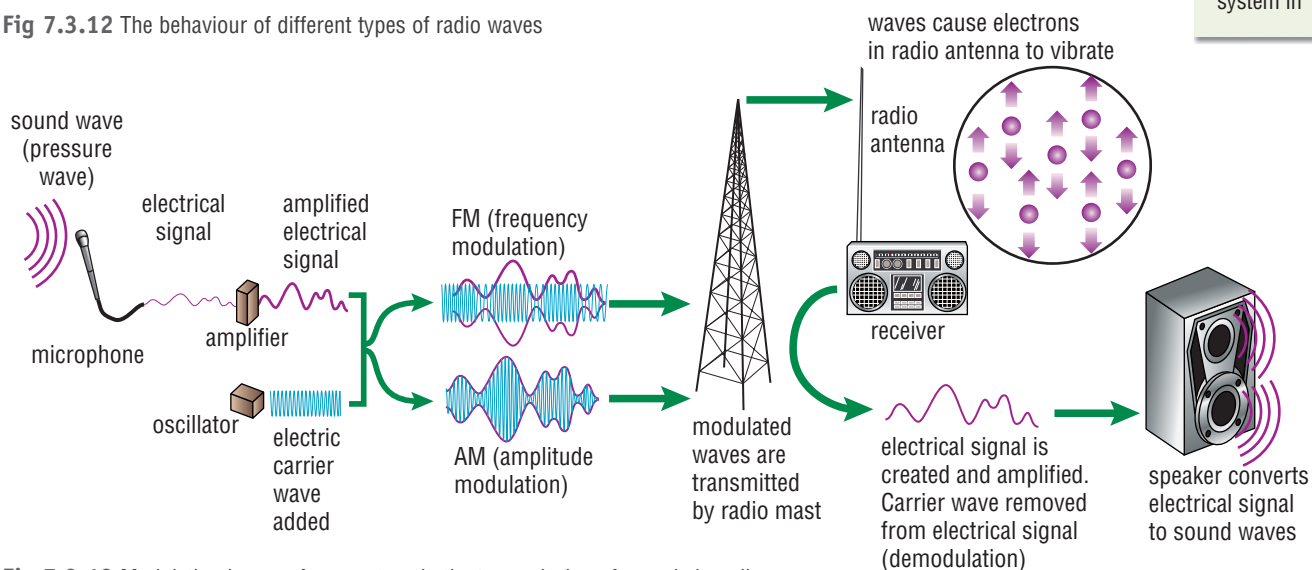

Fig 7.3.13 Modulation is one of many steps in the transmission of sound via radio waves.

7.3 QUESTIONS

Remembering

- List** the two types of waves, giving an example of each.
- State** whether the following statements are true or false.
 - All electromagnetic waves move at the same speed.
 - Each different colour of light has a different wavelength.
 - The visible spectrum contains the electromagnetic spectrum.
 - Waves transfer energy by moving particles along with them.
- State** the speed of light.
 - List** six examples of waves that travel at this speed.
- List** the main types of waves in the electromagnetic spectrum in order from shortest to longest wavelength.
- Name** the harmful rays that are released in a nuclear explosion.
- State** the wavelength of the wave shown in Figure 7.3.14. **N**

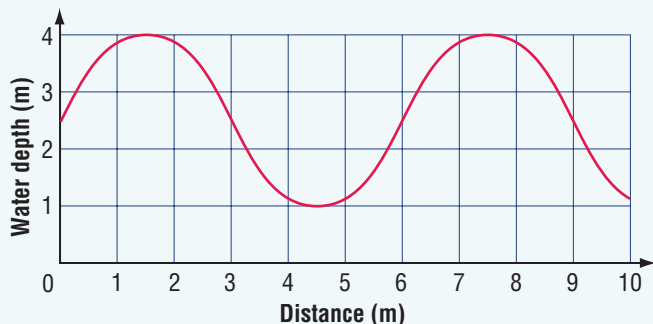

Fig 7.3.14

Understanding

- Outline** the purpose of modulating radio waves.
- Explain** why it does not make sense to talk about the wavelength of white light.
- Infra-red cameras can help find a lost bushwalker. **Outline** how this is possible.
- Explain** how a Geiger counter and gamma radiation can be used to measure the thickness of an object.

Applying

- Identify** which colour of light has the:
 - greatest wavelength
 - highest frequency
- Identify** the radio wave that can penetrate the Earth's atmosphere.
- A student shakes out 20 waves on a slinky in 10 seconds. **Calculate** the frequency of the waves. **N**
- The time between each wave passing is called the period. **N**
 - Identify** the period for the waves in question 14.
 - If the wave frequency increases, **predict** what effect this will have on the period.
 - The period will increase.
 - The period will stay the same.
 - The period will decrease.
 - There is not enough information to answer the question.
- Calculate** the speed of the following waves:
 - a water wave of frequency 0.5 Hz and wavelength 4 m
 - a sound wave of wavelength 3.3 m and frequency 100 Hz
 - a light wave of frequency 6 Hz and a wavelength of 500 nm ($500 \times 10^{-9} \text{ m} = 5 \times 10^{-7} \text{ m}$) **N**
- Identify** which type of electromagnetic wave has a wavelength of:
 - 1 m
 - 1 km
 - 0.5 mm
 - 1 millionth of a millimetre **N**
- Calculate** the value of:
 - 600 nanometres in metres
 - 0.000 000 850 metres in nanometres **N**
- Calculate** the frequency of carrier waves transmitted by: **N**
 - 107.5 ZZZ FM
 - 1278 2AW (an AM station)

Analysing

20 Compare the following by listing their similarities and differences:

- a radio waves and microwaves
- b blue and red light
- c AM and FM

Evaluating

21 Is UV radiation good, bad or both? **Justify** your answer.

Creating

22 Construct a diagram of a transverse wave that has:

- a a wavelength of 3 cm and amplitude of 2 cm
- b a wavelength of 10 cm and amplitude of 1 cm

23 Construct a table like the one below and enter information about each type of electromagnetic wave, as shown with the example.

24 Construct a diagram of:

- a a frequency-modulated carrier wave
- b an amplitude-modulated carrier wave

Type of electromagnetic radiation	Typical wavelength (approx)	Source	How it is detected	Use/s
Visible light	1 millionth of a metre	The Sun, very hot objects	Cones in the eye, photographic film	Sight, photography

7.3 INVESTIGATING

Investigate your available resources (for example, textbooks, encyclopaedias, internet) to complete the following tasks.

- 1 Outline the contribution to science of one of the following people by writing a brief biography of their life.
 - a Scottish physicist James Clerk Maxwell and his work on electromagnetic wave theory
 - b the development of radio communications by the American engineer Edwin Armstrong
 - c the first transmission of radio waves by Guglielmo Marconi
 - d John Logie Baird's contribution to the development of television
- 2 Radio waves include LW, MW, SW, VHF and UHF.
 - a State what these stand for and why the waves are classified like this.
 - b Describe uses for each type of wave in communications.

3 Design an experiment to **investigate** how ripples in a tank or pond are affected by a change in water.

4 Find a design for a simple radio or 'crystal set' (e.g. from an electronics shop or the internet), then construct and test it.

e-xploring

To complete a tutorial on the electromagnetic spectrum, a list of web destinations can be found on **Science Focus 4 Second Edition Student Lounge**. Record the outcome of your tutorial in your notebook.



7.3 PRACTICAL ACTIVITIES

1 Waves in a slinky

Aim

To investigate the movement of waves in a slinky

Equipment

- a slinky
- masking tape
- stopwatch
- floor or corridor space in which to generate waves between points 5 to 10 metres apart

Method

- 1 With a partner, stretch a slinky to a length of 5 metres or so without permanently deforming it.
- 2 Use masking tape to mark points along the slinky every metre or two.
- 3 Generate a horizontal transverse wave as shown, carefully observing the masking tape labels as the wave passes them.
- 4 Generate a small wave and measure the time it takes to get to the other end. Calculate the speed of the wave.
- 5 Keeping the slinky stretched by the same amount, generate a bigger wave and calculate its speed.
- 6 Generate waves at a high frequency and calculate their speed.
- 7 Repeat but for waves of low frequency.
- 8 Investigate what happens when waves are generated simultaneously from both ends of the slinky:
 - a on the same side
 - b on opposite sides

Questions

- 1 **Describe** the direction in which the masking tape labels move when compared with the travelling wave.
- 2 **Describe** whether the wave speed is affected by:
 - a the size of the wave
 - b the frequency of the waves
- 3 **Describe** what happens when waves meet:
 - a on the same side of the slinky
 - b on opposite sides of the slinky

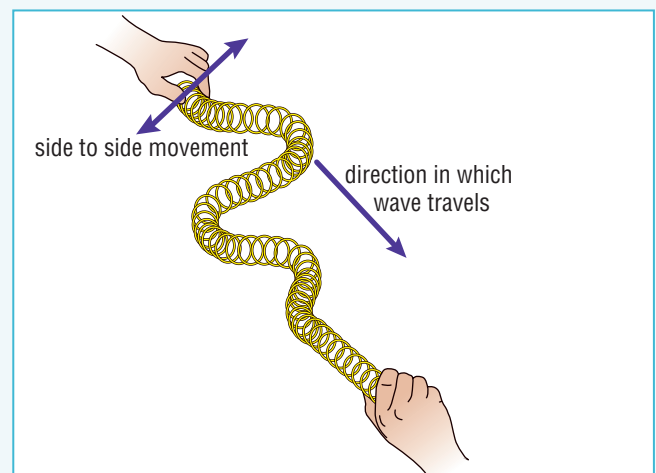

Fig 7.3.15

2 Other waves on the slinky

Aim

To investigate the movement of waves in a slinky

Equipment

- a slinky
- masking tape
- stopwatch
- floor or corridor space in which to generate waves between points 5 to 10 metres apart

Method

Longitudinal waves

- 1 With a partner, stretch a slinky to a length of 5 metres or so without permanently deforming it.
- 2 Use masking tape to mark points along the slinky every metre or two.
- 3 Generate a longitudinal wave by either bunching up and releasing coils quickly or moving the end of the slinky quickly back and forth.

Standing waves

Standing waves are waves that seem to go nowhere; they simply 'stand' on the spot. They are produced when waves come from either end of the slinky at just the right rate to create them. Standing waves often form when waves are being reflected off the opposite end to which they were originally generated. Nodes form where there is no movement in the spring.

- 4 As before, stretch a slinky to a length of 5 metres or so without permanently deforming it.
- 5 With a partner firmly holding one end, generate transverse waves with a repeated sideways flick. The waves generated at each end will reflect and interact. If the ends are flicked at just the right frequency, a standing wave will form. When one happens, mark the position of its nodes and note whether they separate the spring into halves, thirds, quarters and so on.
- 6 Flick the spring faster or slower to produce other standing waves.

Questions

- 1 For the longitudinal wave: in which direction did the masking tape labels move relative to the direction of the travelling wave?

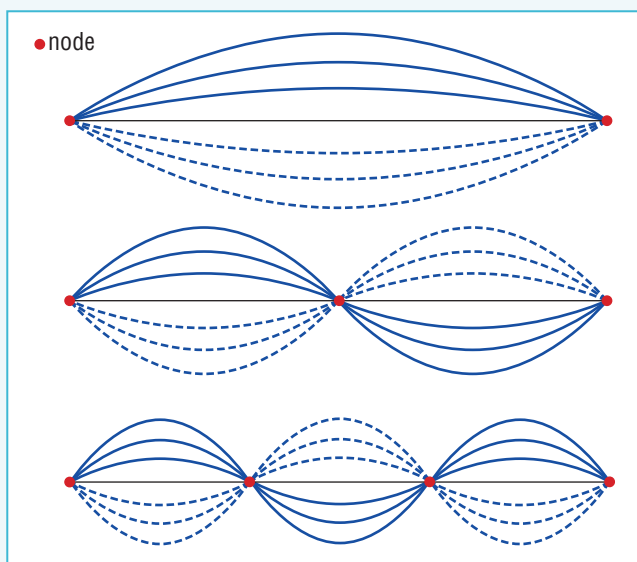

Fig 7.3.16

- 2 Draw a simple diagram for each of the standing waves produced.

3 Polarised!

Sunlight consists of waves in all sorts of orientations. Polarising materials allow only waves whose electric fields vibrate in a certain direction to pass, absorbing all other waves. This reduces glare dramatically. Hence polarising materials are often used in the lenses of sunglasses.

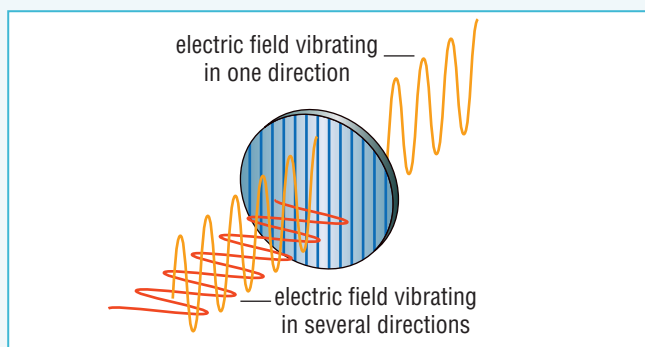

Fig 7.3.17 Polarising filters reduce glare by absorbing much of the light passing through them.

Aim

To investigate the interaction of two polarising filters

Equipment

- two polarising filters
- window or other light source

Method

- 1 Look through one of the filters at a nearby window or other light source.
- 2 Now hold a second filter in front of the first, and rotate it while keeping the first filter still.

Questions

- 1 **Describe** what you saw in each case.
- 2 **Explain** your observations.

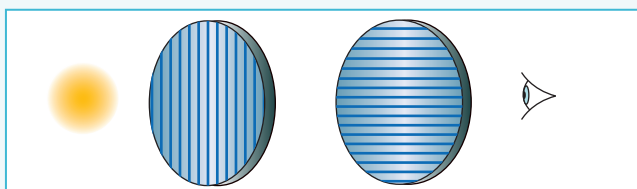

Fig 7.3.18

Unit 7.4

The communications network

context

The first Europeans who settled at Sydney Cove received all their messages from the outside world by sailing ship. Most communication was with England, and messages took a year to get there and another for the answer to return. Instantaneous communication is taken for granted today. Mobile phones, SMS,

email, Bluetooth and the internet give us immediate access to each other and to news breaking around the world. But it wasn't always this way: these technologies were in their infancy only 10 to 15 years ago and few had access to them. Modern communication systems began with the telegraph. Who knows where they will end!



Fig 7.4.1 Alexander Graham Bell demonstrates his telephone.

The telegraph

A basic **telegraph** was invented in 1835 which used electromagnetism to move small compass pointers. By 1844 a more practical version of the telegraph was developed. It used a simple electric switch (a telegraph key) to send coded electrical pulses along cables.

Telegraph cables were soon laid across continents and oceans. Tasmania was linked to mainland Australia in 1869 and Adelaide was connected to Darwin via the Overland telegraph line in 1872. There it joined an undersea cable to Java, connecting with cables to Europe and England. Although messages still took hours to get there, they were rapid when compared to the previous record of two months by ship. Telegraph was the main form of telecommunication until the invention of the telephone.

A	•—	J	•—•—	S	•••	1	•—•—•—
B	••••	K	•—•	T	—	2	••—•—
C	•••••	L	••••	U	••—	3	•••—
D	•••	M	—•—	V	•••—	4	••••—
E	•	N	—•	W	•—•—	5	•••••
F	••—	O	—•—•	X	••••—	6	—••••
G	—••	P	•••••	Y	••—•—	7	•—•••
H	••••	Q	—•••	Z	—•••	8	—•—••
I	••	R	••••			9	—•—•••
FULL STOP	•••••					0	—•—•—•
COMMA	••••••					(zero)	

Fig 7.4.2 Morse code was a code sent as a series of dots and dashes. On receipt, these were printed out or converted to audible clicks that were 'translated' by a telegraph operator. In Morse code, the most commonly used letters have the shortest codes.



Science Clip

Patent problems

Italian inventor Antonio Meucci is credited in his home town of Florence with inventing the first telephone, but he was unable to afford the US\$250 to patent his idea.

The telephone

Scottish inventor Alexander Graham Bell (1847–1922) made the first telephone call on his newly invented phone in 1876. It travelled 3.2 kilometres to his assistant, telling him ‘Mr Watson, please come here—I want to see you’.

Early telephone exchanges required a **switchboard** operator to physically connect one telephone to another with a line. As the number of calls increased on the network, this manual system soon became too clumsy and mechanical exchanges were developed. These found free lines and connected callers automatically. All Australian exchanges are now fully automatic and switching is computerised to enable calls to be continually rerouted to make best use of available lines.

Mobile phones

Mobile phones use microwaves to transmit **digital signals** within a network of regions called **cells**. Each cell uses a different set of frequencies, with no adjacent cells using the same frequency. Base stations detect signals from an activated mobile phone, pinpointing where it is. The base station receiving the strongest signal sends it to the exchange. When ringing a mobile, the exchange sends the call to the base station of the cell it is in.



Fig 7.4.3 All mobile phones have automatic gain control (AGC) which amplifies your voice if you speak too softly. It also softens your voice if you shout, making shouting pointless.

Today's communications network

The global communication network must continually handle massive amounts of voice, written data, computer data, static images and moving vision. It copes by transmitting several signals at once in each line.

Analogue signals

When you talk into a telephone, the initial information is in the form of sound waves. These are converted into electrical signals known as **analogue signals** which are then transmitted via copper wires into the communications network.

Several calls can be transmitted simultaneously by sending them at different frequencies. They can then be separated at the receiving end. This is known as **frequency division multiplexing**, or **FDM**.

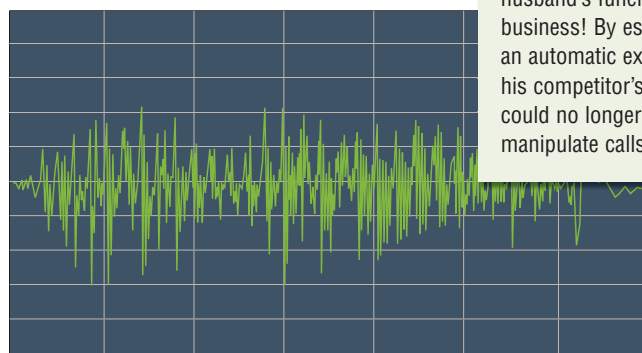

Fig 7.4.4 Analogue signals mimic the form of the sound wave that generated them. This wave says ‘Hello’.

Digital signals

Digital signals are easier to manipulate than analogue signals and give better reproduction and less distortion. Information is sent as short pulses of light or electricity in combinations of the digits 1 (pulse) and 0 (no pulse).

Each phone call is sampled 8000 times every second and is converted into a digital signal. Several different calls can be cut into chunks and interspersed. They are sent down optic fibres at a single frequency in one ‘data stream’, to be sorted out again at the end of the transmission. This is called **time division multiplexing**, or **TDM**.

The amount of information that may be carried is termed **bandwidth**. Bandwidth is maximised by combining FDM with TDM.

Science Clip

The call of the dead!

Almon B Strowger was an American funeral director who invented the first automatic telephone exchange. It is rumoured that his incentive was to stop the flow of business going to his opposition. The operator at his local manual exchange was apparently directing all funeral queries to her husband's funeral business! By establishing an automatic exchange, his competitor's wife could no longer manipulate calls.

Science Fact File

Digital codes

Information can be represented by combinations of the digits 1 and 0. This makes it much easier to accurately transmit since short pulses of light or electricity can represent the 1 and 0 combinations. For example, any number can be represented as combinations of 1 and 0 by imagining place value columns as shown below. Starting from the right, we use 1 or 0 to build up the number in digital form. For example, 5 in digital form is 101 (or pulse, no pulse, pulse). Numbers in this form are also called binary numbers. Each 1 and 0 is called a bit, so the binary number 101 is composed of three bits.

5		
4	2	1
1	0	1

a 3-bit binary number

13			
8	4	2	1
1	1	0	1

a 4-bit binary number

Fig 7.4.5 The numbers 5 and 13 in binary form

Components in the communication network

Small-scale links in the network are copper wire while major links are provided by coaxial cable, fibre-optic cable and radio waves and microwaves. Signals need to be converted back and forth between analogue and digital as required by each section of the network. Each conversion needs a modem.

Science Clip

www.TIM

The very first message sent from one computer to another was 'login', in 1969 from the University of Los Angeles (UCLA) to Stanford Research Institute. The Stanford computer couldn't cope and crashed! TIM (The Information Mine) was also developed in 1969. TIM later became the Information Mesh which went on to become the WWW (World Wide Web). In 1972 there were just 37 internet sites!

The modem

Copper cables can only carry analogue signals. A computer, however, produces digital signals. It needs a **modem** to convert digital signals into analogue signals for transmission into the communications network. This process is called **modulation**.

A modem is also needed for **demodulation**, the conversion of analogue signals received from the network into digital signals for the computer. This dual capability is where a modem gets its name: modulator-demodulator.

Coaxial cables and optic fibres

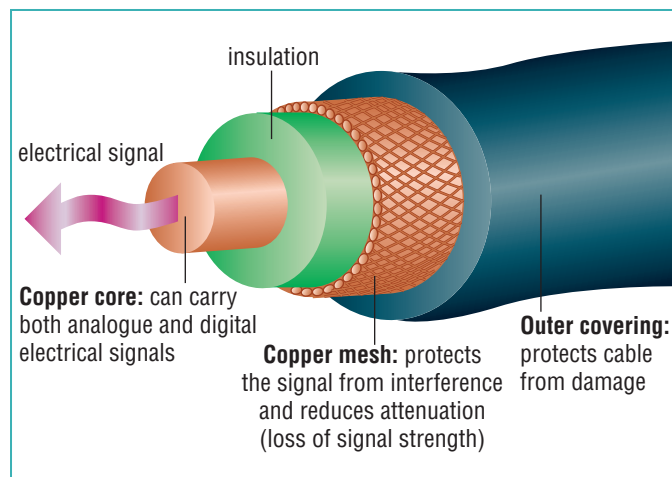

Fig 7.4.6 A single coaxial cable. Several are normally packed into one larger cable.

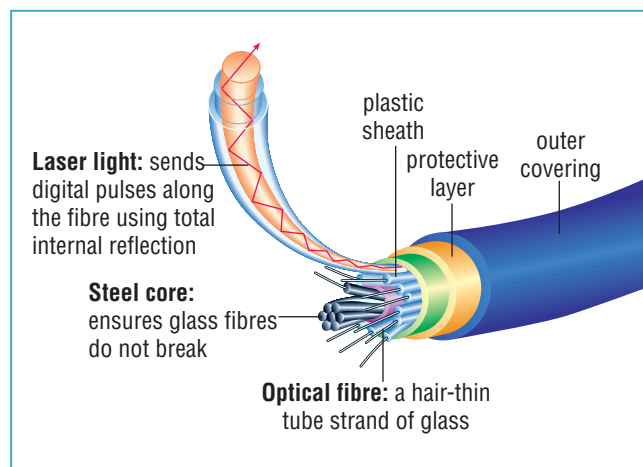

Fig 7.4.7 Optical fibres form the backbone of today's communications networks. Many optic fibres fit into one cable.

Worksheet 7.4 Digital communication

Lasers

Digital signals are sent down optical fibres using pulses of laser light. Laser light is different to normal light in that it is **coherent**. All of its waves are of the same frequency and wavelength and are 'in step', resulting in a powerful beam that may carry vast amounts of information with little loss due to **dispersion** (spreading out). Lasers can be switched on and off many millions of times every second, making them ideal for transmitting digital data.

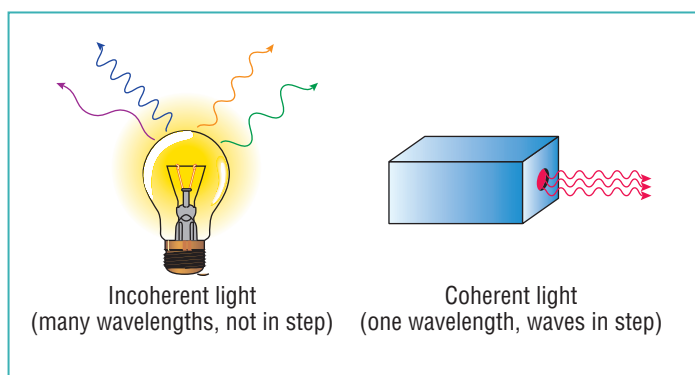

Fig 7.4.8 Lasers form coherent light, all the waves being in-step and of one wavelength and all going in the same direction. Normal bulbs produce incoherent light.

Microwaves

Microwaves are used to transmit digital signals directly from repeater station to repeater station. Since microwaves travel in straight lines, these stations must be in sight of each other. They boost the signals and make sure the signals go where they should. Microwaves also link satellites and mobile phones into the communications network.

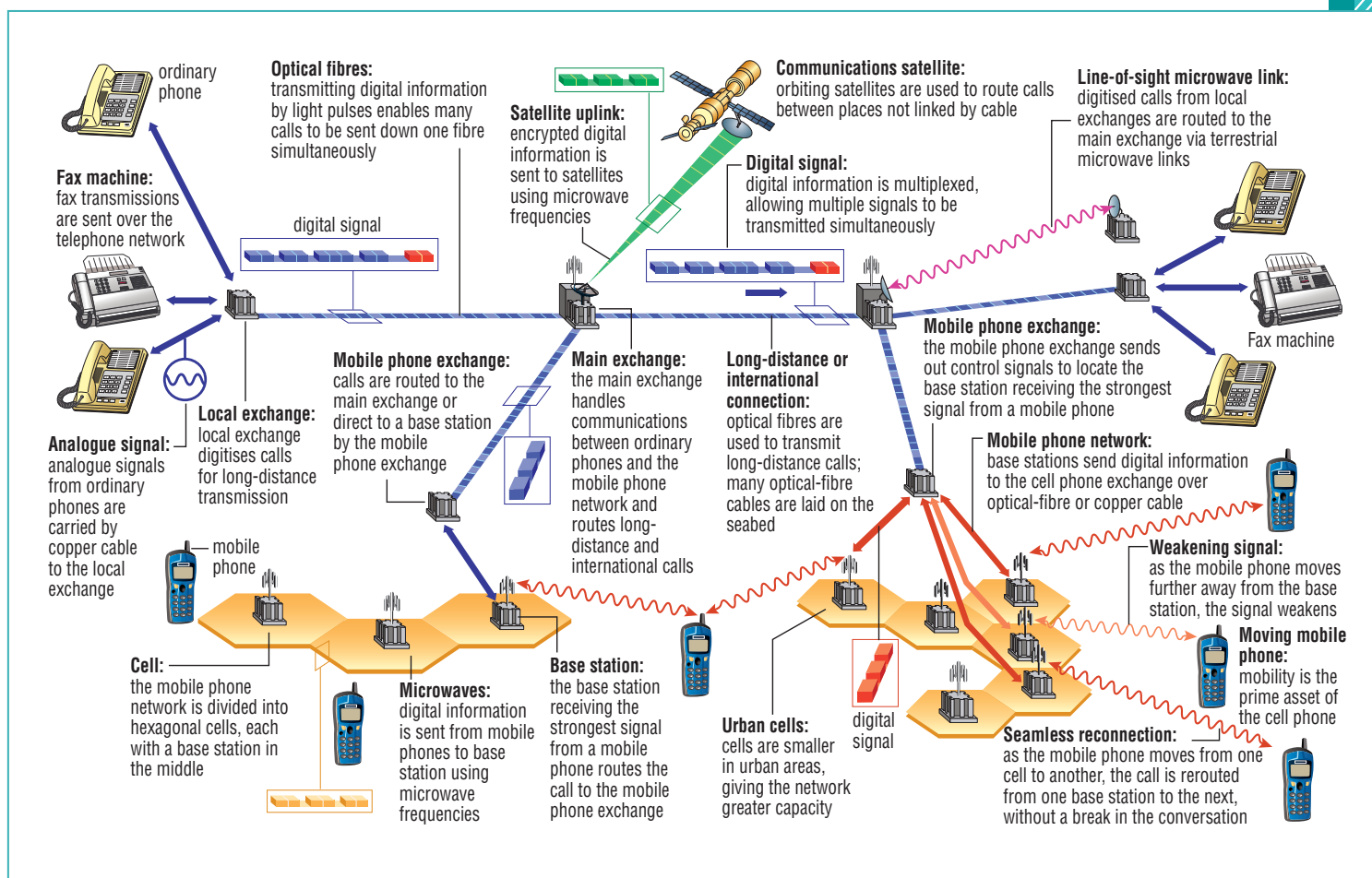

Fig 7.4.9 The global communications network

Science Clip

Active Denial System

The United States military are testing a microwave beam on volunteers as part of research on non-deadly but effective weapons, mainly against protestors. The microwave beam heats up metal parts of their clothing until they have to flee.

Creating

21 Construct your name in Morse code.

22 Construct a Morse code message and use a pencil to tap it out to a partner. Tap sharply for 'short'. Tap then rest for 'long'.

23 Construct a suitable graph showing the different call capacities of the various cables and microwaves.

7.4 INVESTIGATING

Investigate your available resources (for example, textbooks, encyclopaedias, internet) to complete the following tasks.

- 1** Research why there is concern about the effects of mobile phone radiation on the user's brain.
 - a** Gather evidence supporting or denying this effect.
 - b** Evaluate your evidence and decide whether it is a concern.
 - c** Propose ways in which users of mobile phones can reduce the possible risk.
 - d** Present your information as an advertisement (radio, print or television) to pass on your findings to others.
- 2** Research the lives of one of the early telecommunications inventors and write an autobiographical account of their achievements. 

3 Explain how the Overland telegraph works, considering that it has just one wire connecting two places (the original Overland telegraph line was a single strand of wire that transmitted signals using pulses of electric current). There must be a complete circuit for electricity to travel.

4 Research the development of the internet/World Wide Web. Explain the role of routers and servers in this vast network.

e-xploring



To view the Telstra Telecommunications Timeline, a list of web destinations can be found on **Science Focus 4 Second Edition Student Lounge**. Choose ten significant milestones over the years and construct your own timeline.

7.4 PRACTICAL ACTIVITIES

Locating another mobile phone



Method

It takes time for a mobile to find another mobile phone. Use one mobile to ring another mobile phone in the class. Start a stopwatch as soon as the dial button is pressed. Stop the stopwatch as soon as the other mobile rings.

Use this idea to **design** your own experiment that investigates:

- if the time delay depends on the phone company or provider that the mobile is operating through
- the time delay when ringing from a mobile phone to a landline. Is it the same, shorter or longer than to another mobile?
- the time delay when ringing from a landline to a mobile
- the time delay when ringing from a landline to another landline.

Record all results obtained in an appropriate table. Analyse the data and suggest why there may be differences in the time delays. Write a conclusion to the investigation.

CHAPTER REVIEW

Remembering

- 1 State** the units used for the following measurements, giving the full name and short version in each case.
 - a voltage
 - b resistance
 - c current
- 2 List** two types of wave that are possible in a slinky.
- 3 List** five modern electronic devices.
- 4 List** four categories of electromagnetic waves and state a use for each type.
- 5 State** what each of the following people is famous for.
 - a Samuel Morse
 - b Alexander Bell
 - c Almon Strowger
 - d William Shockley
- 6 State** what happens to the wavelength of electromagnetic waves as the frequency increases.

Understanding

- 7 State** three ways in which messages are sent within today's global communications network and **outline** an advantage of each method.
- 8 Match** the following terms to their definitions.

Term	Definition
load	uses up electrical energy
voltage	the ability of a substance to reduce the flow of current
current	wires for the electricity to flow through
conducting path	the flow of charge, usually electrons
resistance	turns the current on and off
switch	the energy available to push current through a circuit
- 9 Copy** the following and **modify** any incorrect statements to make them true.
 - a A magnetic field is produced by a coil or coils of wire, not by a straight wire.
 - b Electricity can cause magnetism and magnetism can cause electricity.

- c Electromagnets can be turned on and off.
 - d A relay is an electromagnetic switch.
 - e A generator produces current when a magnet sits inside or near its coils.
 - f More energy is lost in power transmission lines when the voltage is higher.
- 10 Explain** why not all power is transmitted at 240 volts.
 - 11 Outline** how early telegraphs used electromagnetism.
 - 12 State** which type of transformer is used close to homes, and **explain** why.
 - 13 Predict** what might happen if the same frequency was used for two different calls in a mobile phone cell.
 - 14 Explain** why radios were so large and heavy before transistors were invented.

Applying

- 15 Using** Ohm's law, **calculate** the missing values to complete the following table. **N**

Current	Voltage	Resistance
3 amps	15 V	
10 amps		6 k Ω
	240 kV	32 Ω

- 16 Correct** the following statements by **identifying** the correct word in brackets.

Series circuits

 - a The voltage is shared (unequally/equally) between each resistor.
 - b The current is (the same/different) for each resistor.
 - c If any component is removed, the circuit (will/will not) work.

Parallel circuits

 - d The voltage is (the same/different) for each resistor.
 - e The current (divides into/is the same in) each branch of the circuit.
 - f If one branch of the circuit is broken the other branches (will/will not) still work.

Analysing

- 17 Distinguish** between a series circuit and a parallel circuit.
- 18 Distinguish** between AC and DC.
- 19** Complete the following table **comparing** a water circuit to an electrical circuit.

Electrical circuit	Water pump circuit
Switch	
Battery	
Resistor	
Voltage or energy	
Current	
Wire	

- 20 Contrast** the visible spectrum with the electromagnetic spectrum.
- 21 Contrast** laser light with light from the Sun.
- 22** The following wave was produced in 10 seconds.
Calculate the:



Fig 7.5.1

- a** frequency
- b** wavelength
- c** amplitude

- 23** The following signal consists of two messages sent using time division multiplexing in groups of four characters:
MYHO THEP VERC RICE RAFT OFEG ISFU GSHA LLOF SGON
EELS EUP!

a Analyse the signal and record its two messages.

Evaluating

- 24 Propose** how 0s and 1s could be used to send a digital message originally written in words.

Creating

- 25 Construct** diagrams of the following circuits:
- a** a series circuit with two lights and a switch
- b** a circuit with three lights in parallel, and switches to turn all lights off separately
- c** a circuit with three lights in parallel, and a single switch to turn all lights off
- 26 a Construct** a graph of Ohm's law using the experimental results listed below.
- b Identify** what the slope of the graph represents.
- c Calculate** the slope of the graph. **N**

Voltage, V (volts)	Current, I (amps)
0	0
2.5	2
5	4
7.5	6
10	8

 **Worksheet 7.5** Crossword

 **Worksheet 7.6** Sci-words

 **PP**
Chapter Review Questions

 **PP**
Interactive

8

Global issues

Prescribed focus area

The implications of science for society and the environment

Key outcomes

5.4, 5.6.5, 5.11.1, 5.11.2, 5.12

- Different viewpoints exist about major scientific issues.
- The nuclei of atoms can release energy and particles during fission and fusion reactions.
- Energy is a vital resource.
- Excessive use of fossil fuels is a contributing factor to the enhanced greenhouse effect.
- Biotechnology has brought both benefits and problems.
- There are alternative energy sources, such as solar energy, to using fossil fuels.

- Nuclear fission and nuclear fusion both involve the nucleus but produce their energies in different ways.
- Fusion is cleaner and produces more energy than fission but is currently not viable as an energy source.

Essentials

Additional

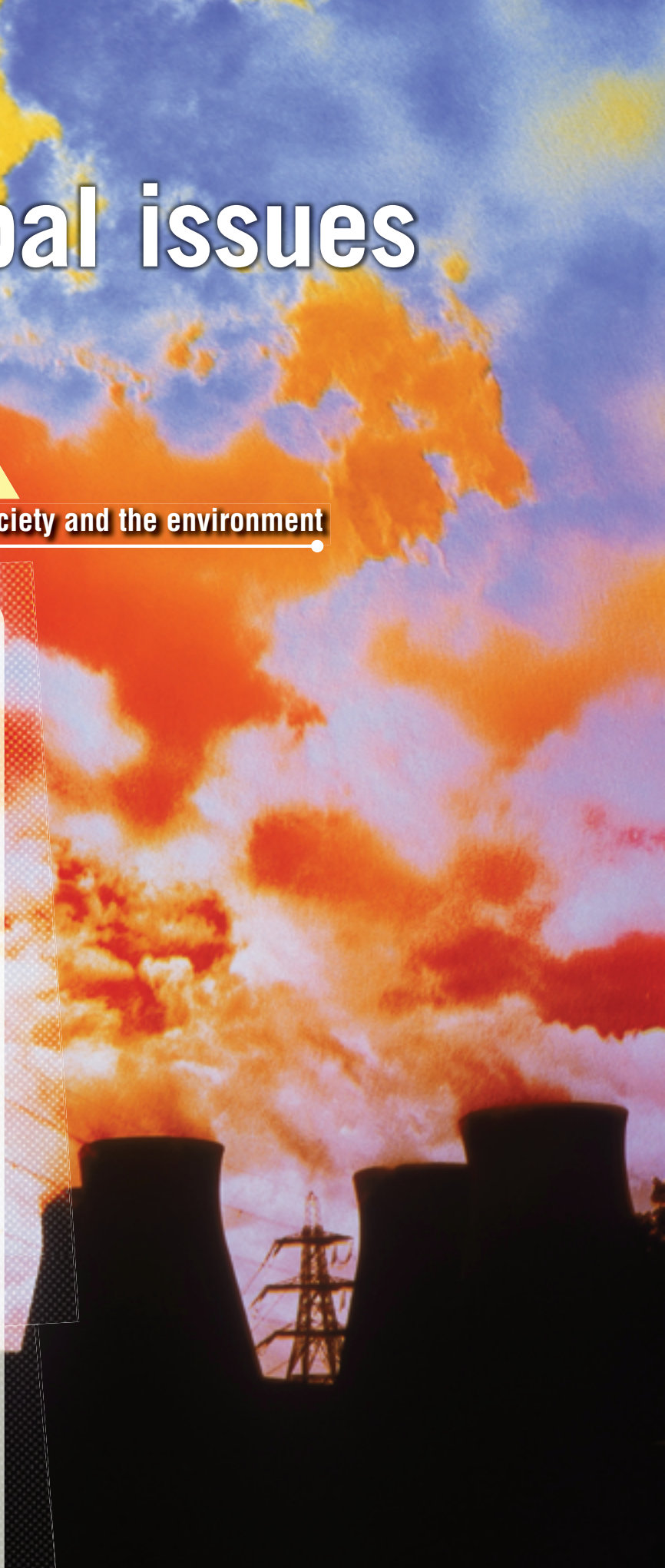

Unit 8.1

Debates in science and society

context

Science is involved in issues that affect everyone's life. The best scientific evidence available should inform debates about scientific issues, but

science alone cannot provide all the answers. Social and economic factors and people's values and ethics are also important.

Debates in society



Science and technology cause changes in society. Often these changes are viewed as progress and as something positive. Sometimes these changes are seen instead as the cause of new problems. New scientific evidence and new technological innovation frequently trigger debates in society. Some of the issues currently being debated in Australian society are whether:

- humans are causing global climate change (global warming) through their activities and what should be done if they are
- nuclear power plants should be built in Australia to meet its future energy needs and whether the risks of doing so are acceptable
- 'clean-coal' and geosequestration technology that traps CO₂ underground can be developed to allow us to continue to burn coal to produce electricity or whether this will still emit far too much of the greenhouse gas carbon dioxide
- it is appropriate to transplant organs from other species into humans (xenotransplantation)
- it is appropriate to use embryonic stem cells to research potential cures to serious diseases
- genetically modified plants should be grown in Australia and whether they are safe as food for animals and humans.

It is necessary for the people participating in these debates to have the best possible scientific evidence available to them. However, more than just scientific evidence is involved in these discussions.

Evidence

Relevant scientific evidence is needed to make decisions about the effects of new technologies and scientific advances on society. Scientific evidence can



Figure 8.1.1 Many argue that the Lucas Heights nuclear reactor in Sydney should be closed down. Although it does pose some risk and produces dangerous wastes, it also produces radioactive isotopes that are used in the diagnosis and treatment of diseases like cancer.



Figure 8.1.2 Genetically modified cotton is resistant to pests that attack 'normal' cotton.

also help people to understand human impacts on the natural environment, as well as to evaluate non-human threats such as meteorites, volcanoes, earthquakes and tsunamis.

In deciding whether it is appropriate to use genetically modified crops for food, scientific evidence needs to be gathered to ensure that foods made from these crops are not poisonous or likely to cause harm. Similarly, food is sometimes ‘irradiated’ with nuclear radiation to kill bacteria. Scientific evidence is needed about whether the irradiation triggers dangerous changes to occur in the food.

Sometimes the scientific evidence is complex and difficult to understand. Weather and climate, for example, are notoriously difficult to predict and model. In the case of climate change the computer models used are huge, requiring massive amounts of computing power and data from sensors all over the world. Climate change happens over huge geographical areas and large time spans—one hot day, or a couple of ‘hotter-than-average’ summers do not necessarily mean that the whole world is getting warmer. Likewise, a ‘colder-than-normal’ winter does not prove that global warming is a myth.

Modelling of future climate relies on scientists making a number of assumptions. Different assumptions lead to different predictions and different opinions, even among scientists. Human production of greenhouse gases has the potential to impact climate change, but so do natural processes and cycles, including cycles in the amount of heat coming from the Sun. The complexity of the evidence means that some debates cannot be simply solved with a yes or no answer based on the scientific evidence.

Go to  Science Focus 4 Unit 5.4



Figure 8.1.3 Australia is bathed in sunshine yet very little of this solar energy is used to generate solar power.

Costs and benefits

Every change has an impact on the economy, the environment, people or all of these. Choosing not to change also has costs.

Decisions and debates in society are usually based on comparing the costs of doing something with the benefits it offers. Electric and hybrid cars, for example, offer the benefits of being quieter and having much lower greenhouse gas emissions than current petrol-driven cars.

However, they have the costs of being slower and more expensive. There is also an infrastructure problem: there are petrol stations everywhere but there are no charging stations for electric vehicles. Also, while a petrol-driven car can be re-fuelled in minutes, the batteries of an electric car usually take hours to charge. With our present levels of technology, the costs of an electric car outweigh its benefits, so most people choose not to buy one.

Science Clip

Hydrogen cars

In 2007, BMW released its Hydrogen-7, a version of its 12-cylinder 7-series luxury saloon. The Hydrogen-7 is produced in limited numbers and sold only in the USA. Water vapour is the only emission it produces. Although not a pollutant, many are frightened of a future where lots of cars are emitting water vapour ... they imagine the slippery roads that might result and the inevitable thick fogs they will cause on cold days.

The ‘triple bottom line’

The ‘bottom line’ in economics refers to the final calculation for a company once all the revenue (money coming in) has been added up and all the costs (money going out) subtracted. It shows whether the company will make a profit or a loss.

Some have argued that it is unacceptable to just look at the bottom line of a company in terms of dollars and cents.

There is a good argument for calculating a company’s ‘triple bottom line’—adding up the benefits and costs of its activities in terms of:

- economics
- their impact on the environment
- their impact on society.

Ethics and values

Different people do not always judge costs and benefits in the same way. These differences are called ‘values’ and different people have different sets of values. Some people, for example, might eat at a fast food restaurant

In Australia, this judgment was made against a background of cheap, abundant fossil fuels such as coal and oil, which seemed to be less dangerous and have less environmental costs. More recently, however, it has been realised that thousands of people die each year when mining coal, and that coal affects the environment with dangerous pollutants such as mercury (Hg) and acid rain. More importantly, fossil fuels release the greenhouse gas carbon dioxide (CO₂) and its role in climate change has been recognised as an important social and scientific issue and challenge.

[Go to](#) [Science Focus 4 Unit 1.3](#)

Figure 8.1.4 Wind turbines produce no greenhouse gases and use a renewable resource. However, they are sometimes viewed as ugly, and do not supply constant power.

because they value convenience and time more highly than healthy food. Others who value losing weight more highly might eat at a vegetarian restaurant or cook their own healthy food at home.

Many values are purely matters of personal taste and choice. Other values are common to almost everyone in society and enforced with laws.

In making decisions about social issues, much of the debate arises from trying to balance different people's values. Although some might be happy to pay more for 'green' electricity derived from renewable sources like wind and hydroelectricity, others would rather have lower power bills. In some cases, however, decisions need to be made for 'the common good'. This means society as a whole agrees with the decisions and will be benefited by them, but debates on these issues can become heated and passionate. The debate about whether Australia should build nuclear power stations is an example of one such debate.

Nuclear power in Australia

In the 1970s and 1980s, nuclear issues seemed very clear. Nuclear power was potentially dangerous (there had been a number of accidents at nuclear power plants) and it created dangerous radioactive wastes which needed to be stored safely for many thousands of years. Many countries, including Australia, chose not to invest in them.

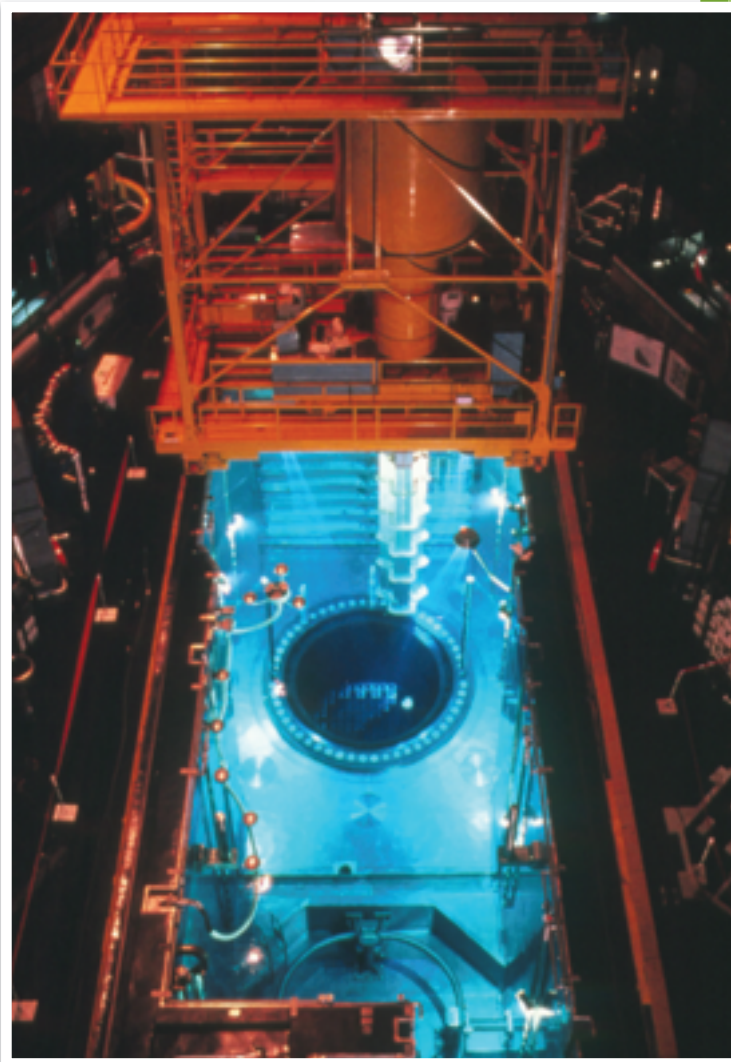

Figure 8.1.5 The Flamanville nuclear power station reactor hall in France

8.1 QUESTIONS

Remembering

- Lucas Heights causes much debate. **State**:
 - what Lucas Heights is
 - where it is located
 - one argument for its continued existence
 - one argument for its closure
- In addition to scientific evidence, **list** the things that need to be considered in debates about science, technology and society.
- Different fuel sources are being investigated to power cars. **State** one advantage and two disadvantages for each of the following fuels:
 - electricity
 - hydrogen

Understanding

- Explain** why many people who were formerly opposed to the use of nuclear energy are taking a second look at the issue.
- Explain** why genetically modified cotton is being planted in Australia instead of 'normal' cotton.
- The main aim of businesses is to make a profit. **Explain** why is it then unacceptable for businesses to only consider 'the bottom line'.
- Describe** some of the costs (environmental and human) associated with the use of:
 - coal-fired power stations to provide Australia's electricity
 - replacing them or supplementing them with nuclear power stations

Applying

- Many people believe that our cities should change so that we won't need to drive cars into the centre of the city. **List** as many costs and benefits as possible of this proposal.
 - In the future, students could use the internet to do their schooling and many office-workers could use the internet

instead of going into the office. **Identify** costs and benefits of such a proposal.

- Look at the lists created for parts **a** and **b**. Does this allow you to make a clear decision about whether to go ahead with such proposals? **Explain** your answer.
- The costs and benefits of business must be considered against three criteria.
 - List** those criteria.
 - Consider the following hypothetical situations and **identify** which criteria each one fails.
 - Shonky PTY LTD wants to install pokie machines in schools so that students can gamble at lunchtimes and after school.
 - Smellsville Water Board wants to dump untreated sewage in the ocean because it will be cheaper for them and will reduce costs.
 - The government of Carphobia is about to ban all cars over two years from its streets.
 - Every car buyer has different values. **Identify** the most important value(s) for these car buyers.
 - David has a family of four kids and two large dogs.
 - Tina lives on a cattle station near Birdsville.
 - Natalie lives in central Brisbane and can walk to work.
 - Greg is 52 but wants to give the impression he is much younger.

Evaluating

- Propose** reasons why Japan built nuclear power plants but Australia did not.

Creating

- Construct** one argument for and one argument against each of the following current debates in Australia:
 - the construction of nuclear power plants
 - research into geosequestration
 - xenotransplantation
 - irradiation of food

8.1 INVESTIGATING

- Investigate** your available resources (for example, textbooks, encyclopaedias, internet) to find out:
 - what is geosequestration?
 - what does it aim to do and why?
 - are there any working geosequestration plants in the world?
- Many governments see geosequestration as one way of keeping coal-fired power plants operating well into the future. Based on your findings, evaluate whether you think we should pursue other methods of power generation or continue burning and exporting our abundant supplies of black and brown coal.

context

The **greenhouse effect** is a natural phenomenon that keeps the Earth at a temperature to sustain life. However, the amount of carbon dioxide in the atmosphere that creates the greenhouse effect is increasing. This has resulted in

global warming. Scientists have been investigating the effects of global warming, such as the El Niño effect, for several decades. It is only recently that they have looked at the impact of global warming, such as rising sea levels and flooding, on specific locations.

The greenhouse effect

The greenhouse effect is caused by the gas **carbon dioxide** (CO_2) together with other gases in the atmosphere. These gases are known as the greenhouse gases. Too little of these greenhouse gases, and the planet would be too cold to sustain life. Too much, and the resulting high temperatures would also be unsuitable for life. The **greenhouse effect** is natural and is required for the continued survival of all Earth's species. Earth would be about 30°C colder on average if there were no greenhouse gases.

How it works

Carbon dioxide and other gases in the atmosphere behave like the glass in a greenhouse or car windows. Energy from the Sun reaches the Earth as electromagnetic waves with a **short wavelength**. These waves are able to pass through the atmosphere (and glass). The energy is absorbed by the Earth. The radiation that is emitted back into the atmosphere has a **long wavelength**. Carbon dioxide and other gases block the transmission of long wavelength radiation. Most of this radiation is prevented from leaving the Earth's atmosphere. Much of this energy is therefore trapped in the atmosphere, warming the Earth to a temperature suitable for life.

Go to  Science Focus 4 Unit 7.3

Science Clip

The hot car effect

A car left in the Sun on a fine day can become extremely hot inside. The temperature can easily reach 50°C even when the temperature outside is only between 20°C and 30°C . Heat enters the car easily but much of the heat cannot escape. For this reason, animals and young children should not be left in cars as these high temperatures can kill. The greenhouse effect could well have been called the 'hot car effect', but it is named after greenhouses that trap heat from the Sun to help plants grow more quickly.



Fig 8.2.1 Ice cores give scientists information about past temperatures and atmospheric gases. This climate research scientist examines an ice core in Antarctica.

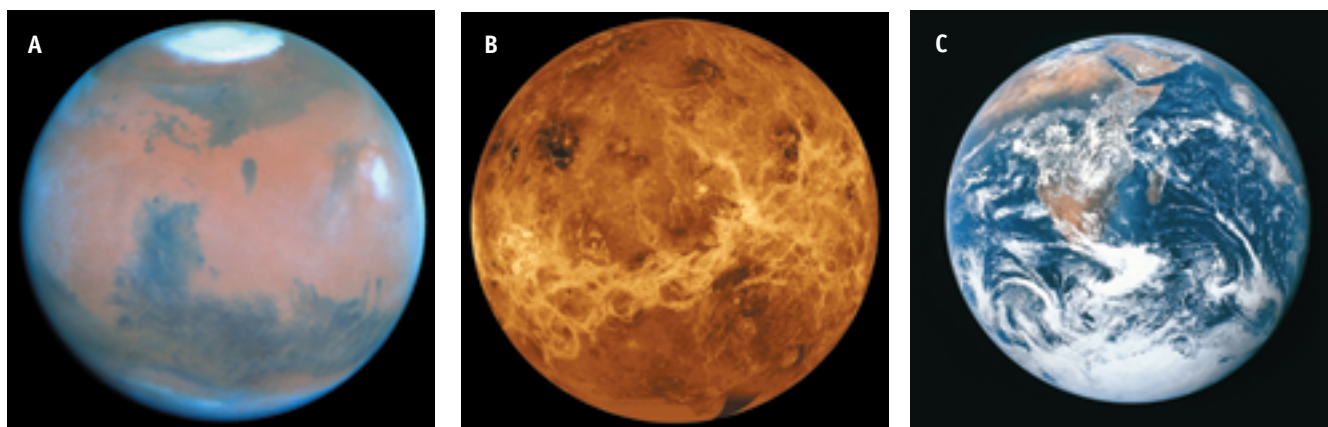

Fig 8.2.2 **A** The surface temperature on Mars is -100°C . Its atmosphere is too thin to produce a life-sustaining greenhouse effect. **B** A massive greenhouse effect caused by Venus's thick carbon dioxide-rich atmosphere causes surface temperatures of 500°C . **C** The Earth's atmosphere is just the right thickness to keep its average temperature at around 14°C .

The enhanced greenhouse effect

Over the last 100 years the levels of greenhouse gases in the atmosphere, particularly carbon dioxide, have increased. The 'blanket' of greenhouse gases in the Earth's atmosphere has effectively become thicker.

This has enhanced the greenhouse effect. The same amount of heat energy is coming in from the Sun, but less is escaping back into space. The enhanced greenhouse effect has led to **global warming**, increasing the average temperature of Earth by about 0.18 degrees Celsius every decade. The hottest years Earth has experienced have all occurred since 1995.



Greenhouse gases

The main greenhouse gas is carbon dioxide. Carbon dioxide is naturally cycled through the environment during photosynthesis and respiration. Over Earth's history the amount of carbon dioxide in the atmosphere has stayed fairly stable as it is both absorbed into living systems and released back into the atmosphere.

CO₂ revolution

The factories, steamships and locomotives of the Industrial Revolution needed fuel to fire their boilers. This came mainly in the form of timber or coal. The modern world also needs fuel. In mainland Australia, coal is still used, mainly to fire the boilers of electrical power stations.

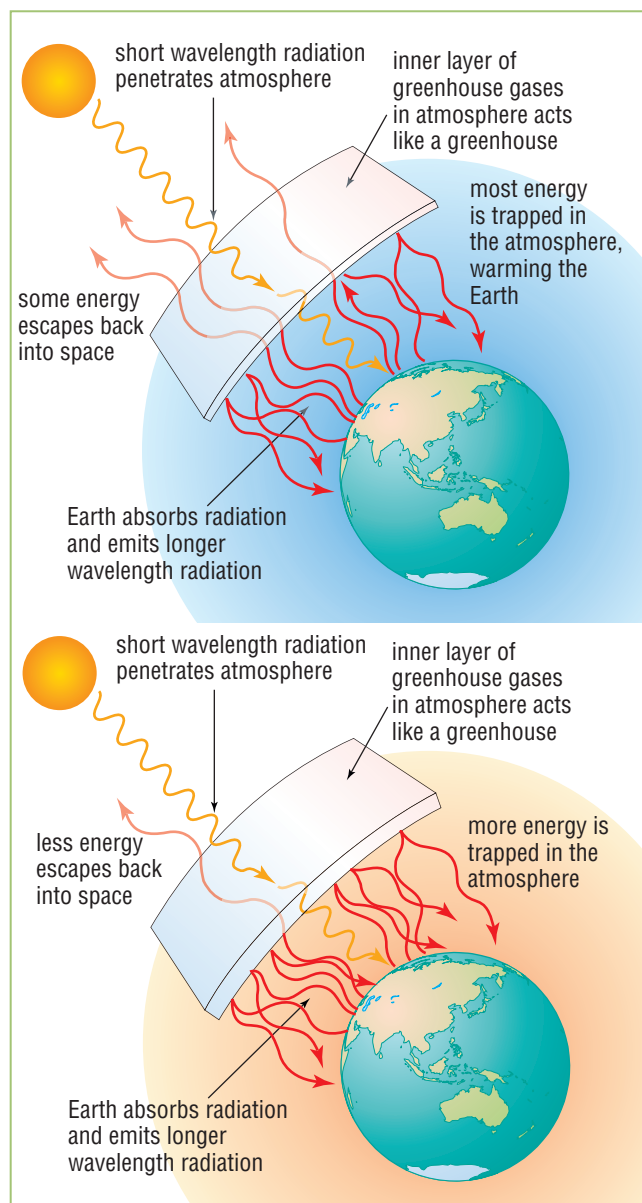

Fig 8.2.3 Natural and enhanced greenhouse effects



Science
Clip

Exit!

There are lots of green and white exit signs in cinemas and shopping malls. All of them need electrical power. It is estimated that just in New South Wales these signs generate 126 000 tonnes of greenhouse gases (mainly CO_2), equal to the output of 25 000 cars! Self-illuminating signs that draw their power from sunlight or from other light sources are available, but make up only one per cent of the world's exit signs.

Science
Clip

You've got gas!

If Australia's yearly production of CO_2 is spread over the surface of mainland Tasmania (area 64 103 km^2) it would form a three-metre-high blanket over the island.

Each year Australia produces 542 600 000 tonnes of greenhouse gases, of which 70 per cent is CO_2 . One tonne of CO_2 occupies 556 000 litres or 556 m^3 (about the volume of a four-bedroom house).

Coal, and the other main fuels, gas, petrol and oil, are called fossil fuels, as they are made from the fossilised remains of long-dead plants and animals. Carbon dioxide is released whenever fossil fuel is burnt. Burning 'unlocks' carbon that has been stored in the Earth for millions of years, producing energy and CO_2 . Coal and gas power stations and industry are leading producers of carbon dioxide. Clearing land of trees (deforestation) by burning forests has a double effect. Not only are greenhouse gases released when forests burn, but the destroyed trees are no longer available to take up and store carbon dioxide.

Around 27 billion tonnes of carbon dioxide are emitted into the atmosphere per year. Some is absorbed, but the rest builds up in the atmosphere with:

- seven billion tonnes absorbed by oceans
- seven billion tonnes taken up by forests
- 13 billion tonnes accumulating in the atmosphere each year.

Other greenhouse gases

Although carbon dioxide is the main greenhouse gas, others include the following.

- **Methane** (CH_4) is produced when vegetation breaks down in the absence of oxygen, for example, in rice paddies, rubbish tips and when cattle (or you) burp or fart. Methane is 21 times more effective than carbon dioxide in blocking the escape of radiant heat from Earth. However, less methane than carbon dioxide is produced.
- **Nitrous oxide** (N_2O) is produced from burning forests, car exhausts and artificial fertilisers.
- **CFCs** or chlorofluorocarbons were, until recently, used in aerosol spray cans, refrigerators and air



Fig 8.2.4 Car exhausts are a major source of excess CO_2 in the atmosphere.



Fig 8.2.5 Deforestation results in an increase in the amount of CO_2 in the atmosphere.

conditioners, to clean circuit boards and in the manufacture of polyurethane foam used in packaging. They are now banned in many countries and are becoming less commonly used worldwide.

- **Surface ozone** is generated as part of **photochemical smog**. It is produced by the action of sunlight on motor vehicle and industrial emissions.

Australia produces approximately 1.4 per cent of the world's greenhouse gases and the breakdown of gases is shown in the table on page 302. Per person, this makes it the world's third worst greenhouse-polluting country, after the United States and Luxembourg.



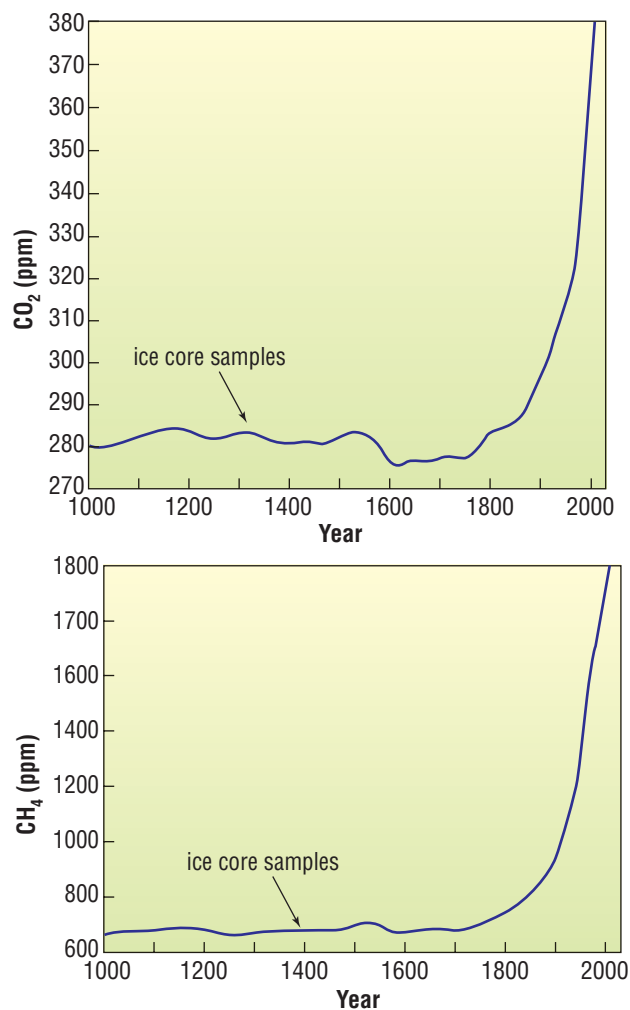

Fig 8.2.6 Concentrations of carbon dioxide (top) and methane between the years 1000 and 2008

Australian greenhouse gas production (excluding land clearing)	
Carbon dioxide	60%
Methane	26%
Nitrous oxide	6%
Other	8%

Greenhouse gases remain in the atmosphere for many years. Carbon dioxide persists for more than 100 years, and methane remains for 11 years. Countries around the world are now putting laws in place to reduce emissions.

Kyoto Protocol

In 1997, the Kyoto Protocol called for developed nations to reduce emissions of greenhouse gases by five per cent by 2012. The Australian Government initially did not ratify the Kyoto Protocol, arguing that it was not in

Australia's economic interest to do so. In 2008, Australia finally signed the Kyoto Protocol. The government is committed to stepping up efforts to reduce Australia's greenhouse gas emissions to only eight per cent more than the levels emitted in 1990. To achieve this, all Australians will need to conserve energy.

Evidence of global climate change

Evidence is mounting that the average global temperature is increasing. Some of this evidence is very obvious.

- Glaciers have been gradually retreating over the last 200 years and are smaller now than ever before.
- The seas north of Canada are usually frozen over every northern winter and only partly break up over the summer. Since 2007, however, enough ice has melted to allow ships to sail between the Atlantic and Pacific Oceans via the Northwest Passage.
- Large coral reefs in the Caribbean are now permanently bleached. This happens when the water is too warm and the coral expels the algae that give it colour. Although rare in the past, bleaching on the Great Barrier Reef now occurs every three to four years. Repeated bleaching kills coral.

Some of the evidence is less obvious, although equally convincing.

- The ice sheet in Greenland is getting thinner.
- The number of alpine plant species found growing in the mountains in Germany has fallen, suggesting that it is now too warm for them to grow.
- In Australia, snowgums do not normally grow on the top of mountains because it is too cold. The treeline has shifted 40 metres up the mountains in the Victorian ski resorts in the last 25 years. This suggests that the mountain-tops are becoming warmer.

All this evidence is relatively recent. More compelling evidence has come from the ice of Antarctica. Scientists collect ice cores from Antarctica by drilling into the ice. The deeper you go into the ice, the older the ice is, as new snow falls on top each year. When the snow falls, air bubbles are trapped in the ice. Analysis of these trapped gases reveals the amount of carbon dioxide in the atmosphere throughout history. So far scientists have drilled down 3.27 kilometres, producing data about carbon dioxide levels going back roughly 900 000 years.

It is normal for the level of carbon dioxide in the Earth's atmosphere to go up and down, but the amount of carbon dioxide in the atmosphere is now at its highest level.

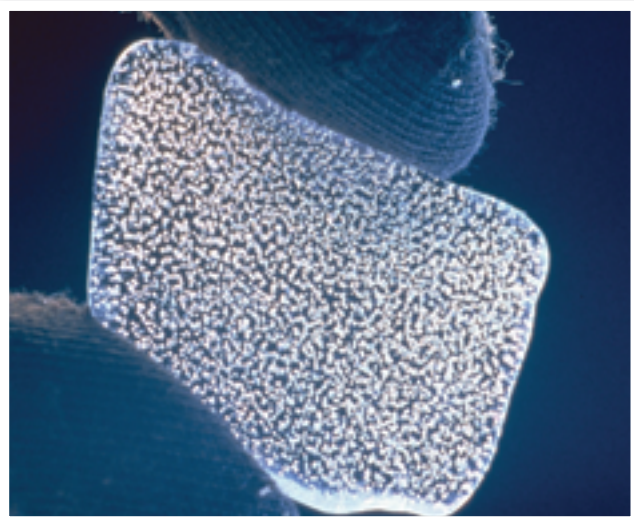

Fig 8.2.7 Part of an Antarctic ice core showing hundreds of tiny, trapped air bubbles

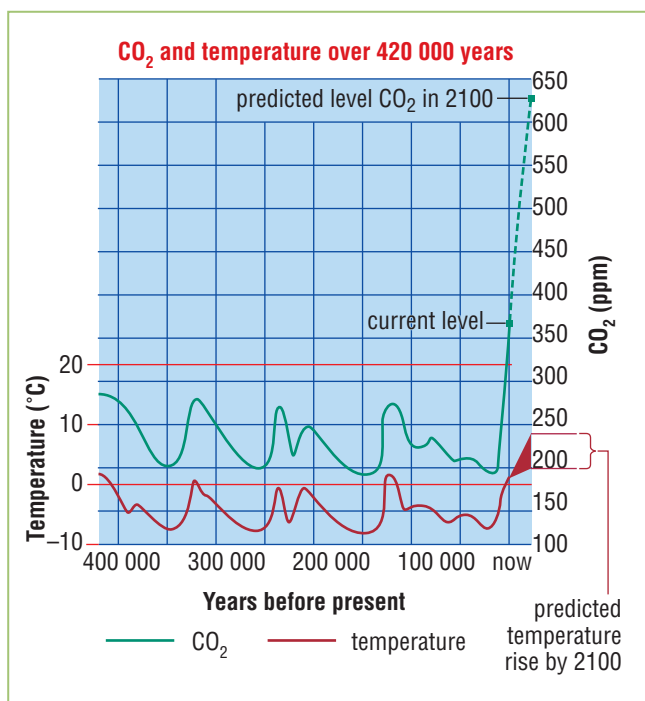

Fig 8.2.8 Carbon dioxide levels in the Earth's atmosphere over the past 420 000 years—the graph shows a prediction for the year 2100 if humans keep increasing carbon dioxide levels at the current rate. Notice that the Earth's temperature changes when the amount of carbon dioxide in the air changes. The troughs on the temperature graph represent the Ice Ages, when the average temperature was about six degrees lower than at present. The peaks are when warmer periods occurred on Earth.

The future

Predicting the temperature rise

Over the past 100 years or so, the Earth's average surface temperature has increased by about 0.5°C . A further increase of between 1°C and 4°C is expected by the end of this century. This temperature increase, which seems small, is enough to raise sea levels by about half to one metre. Land ice at the polar caps is melting and increasing the amount of water in the oceans. This causes flooding of low-lying coastlines. At this rate, the survival of many of the island nations in the Pacific and Indian Oceans would be threatened.

Predicting local effects

Scientists do not fully understand the implications of global warming for society and the environment. Most regions are already experiencing more storms, droughts, floods, hurricanes and temperature extremes.

Australian scientists predict that some of the following changes may occur.

- The continued melting of the polar ice caps will raise sea levels, flooding coasts, cities and some entire island countries.
- Liquid water expands slightly when warmed and so the oceans will expand, also raising sea levels causing further flooding.
- There will be increases in the numbers of wild storms and cyclones. Cyclones could expand to the south of Australia.
- There will be more droughts and heat waves.
- There will be more bushfires.
- There will be less rain and snow. Managing and saving water will become more important.
- Habitats will change, causing the extinction of some animals and plants.
- Increased temperatures may cause bacteria to grow faster, causing more disease in humans and other organisms.
- Some plants may grow faster with higher temperatures. This would be good for farmers, but less rain may mean fewer plant varieties can survive.
- Increased heat may cause more heat stroke and illness, especially in the young and elderly.



Worksheet 8.1 Temperature change

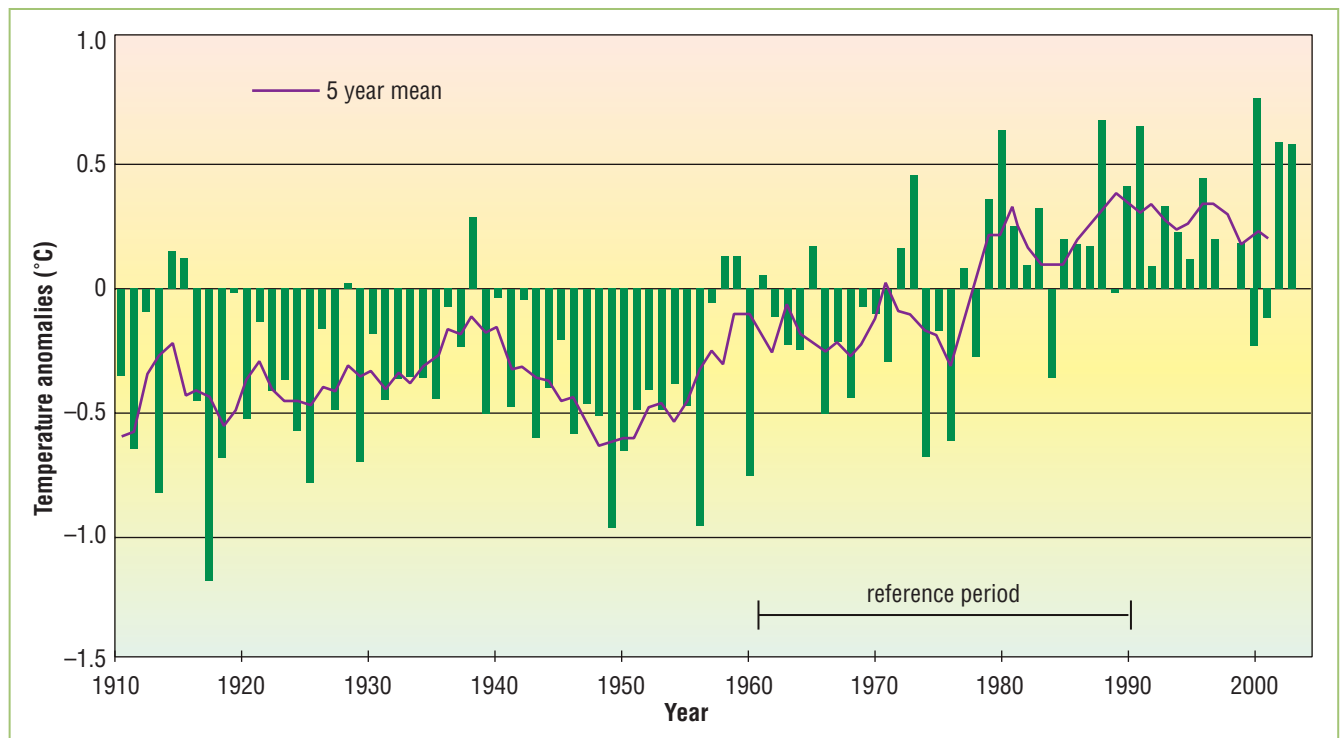

Fig 8.2.9 Australian temperatures have slowly increased over the years. This graph shows Australian temperatures compared with the 1961–1990 average.

Science Clip

See us while we're still here!

The island nation of the Maldives is only a little above the waters of the Indian Ocean. Breakwaters have been constructed in the past 10 years to protect its capital, Malé, from rising waters. In 2004, the Maldives completed construction of a rectangular artificial island that will accommodate the population of Malé which is expected to 'go under' in the next 40 years. The Maldives tourist board is now marketing the island nation as a destination that will be impossible to visit in the future. Some cities around the world, such as New Orleans (USA), are already below sea level. Others, such as London (UK) and Venice (Italy), are just above sea level and are threatened with every storm surge or king-tide. Barriers to protect New Orleans and London have been built and are planned for Venice. Imagine a wall between Sydney Heads!



Fig 8.2.10 New Orleans is already below sea level and was flooded when walls protecting it broke during Hurricane Katrina in 2005.

Worksheet 8.2 Global warming

Worksheet 8.3 Analysing ozone

Prac 2
p. 308

PP
Drag-and-drop

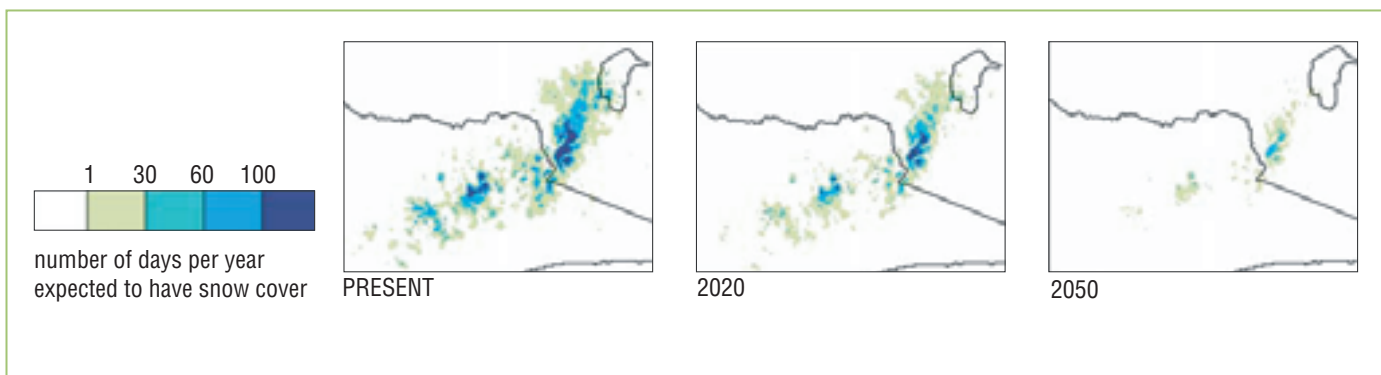

Fig 8.2.11 With global climate change, the alps in NSW and Victoria are expected to have fewer days each year covered in snow.

El Niño

Another factor adding to weather extremes, possibly blurring the effect of global warming, is the **El Niño effect**. The water of the Pacific Ocean is warmer than other oceans. In a normal year, trade winds push this warmer water west towards the east coast of Australia, where high levels of evaporation cause normal amounts of rainfall. Every few years, the trade winds weaken or reverse, allowing warmer water to move towards the west coast of South America. This is called the El Niño effect because it occurs around Christmas time (El Niño means ‘Christ child’ in Spanish). The result is that Australia experiences drought and South America experiences increased rainfall.

Recent Australian research has suggested that warming patterns in the Indian Ocean might have an effect on El Niño, making its effect severe (as in recent years) or milder.



Fig 8.2.12 El Niño is linked to droughts in Australia.

Science Clip

Antarctic meltdown

If all the ice in Antarctica melted, sea levels would rise by 61 metres! Considering the rest of the ice in the world, the rise would be 68 metres, with many inland areas becoming beachfronts!

Science Fact File

Antarctic statistics

- Area: 14.2 million square kilometres or 10% of Earth’s surface (double that of Australia)
- Ice thickness: average 2.5 kilometres, maximum 4.7 kilometres
- Elevation: average 2300 kilometres (Australia’s average elevation is 340 metres)
- Ice content: 90.6% of the world’s ice
- Fresh water: 70% of the world’s fresh water

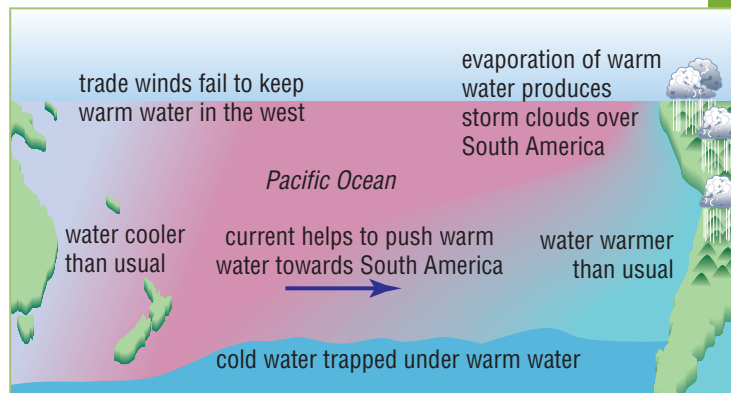

Fig 8.2.13 The El Niño effect

8.2 QUESTIONS

Remembering

- 1 State** the name of the main gas responsible for the greenhouse effect.
- 2 State** the cause of the enhanced greenhouse effect.
- 3 List** two causes of carbon dioxide build-up in the atmosphere.
- 4 State** the average temperature rise during the past 100 years. Is it:
 - A** 0.3°C
 - B** 1.0°C
 - C** 0.5°C
 - D** 5°C

Understanding

- 5 Explain** why greenhouse gases are useful to the Earth.
- 6 Explain** how greenhouse gases trap heat from the Sun.
- 7 Outline** how the temperature of Earth would change without greenhouse gases.
- 8** Clearing land can enhance the greenhouse effect. **Explain** how.
- 9** Use an example to **clarify** how long greenhouse gases persist in the atmosphere.
- 10** Methane blocks the escape of radiant heat much more than carbon dioxide. **Explain** why carbon dioxide and not methane is considered the main greenhouse gas.
- 11** Scientists use ice cores to determine the levels of greenhouse gases in the past. **Explain** how air becomes trapped in the ice.
- 12 Outline** how the levels of carbon dioxide in air bubbles in ice cores have changed in the past 420 000 years.
- 13 Describe** the relationship between the level of carbon dioxide in the atmosphere and the Earth's temperature over the past 420 000 years.
- 14 Describe** how the enhanced greenhouse effect may affect Earth's climate.
- 15 Clarify** what is meant by the term 'El Niño'.
- 16 Outline** two effects of El Niño on Australia.
- 17 Discuss** how global warming might cause greater rainfall.
- 18** Permafrost is permanently frozen soil that is found in many resorts and villages in European mountain ranges. **Predict** a dangerous phenomenon that may occur in these regions as a consequence of global warming.
- 19** Use Figure 8.2.2 to **identify** which planet near Earth has a very enhanced greenhouse effect.

- 20** Copy and complete the following table to **summarise** the main greenhouse gases, their chemical formulae and sources.

Greenhouse gas	Chemical formula	Sources

- The following question relates to the graphs of carbon dioxide and methane concentrations in the atmosphere in Figure 8.2.6. **N**
 - a Describe** atmospheric levels of each gas between the years 1000 and 1400.
 - b Identify** when the amount of carbon dioxide and methane in the atmosphere suddenly increased.
 - c** Estimate the rise in CO₂ and CH₄ concentrations between the years 1800 and 2000.
 - d Calculate** as percentages your answers to part c.

Applying

- A single cow emits 280 litres of methane gas every day. The number of cattle in Australia (referred to as the 'national herd') is about 27 million. **Calculate** and estimate for the volume of methane emitted by the national herd: **N**
 - a** per day
 - b** per year
- 23 Use** the temperature change graph in Figure 8.2.9 to answer the following questions. **N**
 - a** There are two pairs of lines on the graph due to two factors affecting temperature rise. **Describe** what they are.
 - b Assess** the range of the global average temperature rise (compared to 1990) in:
 - i** 2040
 - ii** 2080
- 24** There is roughly one car for every two people in the United States (population 293 million people). In China (with a population over 1300 million or 1.3 billion people) the figure is approximately one car for every 1400 people. There are currently about 500 million cars in the world. **N**
 - a Calculate** and estimate how many cars are in the United States.
 - b Calculate** how many cars are in China.

- c Calculate** an estimate of how many cars would be in China if the car-to-person ratio was the same as that in the United States.
- d Analyse** the consequences for global warming if China had the same car-to-person ratio as the United States.

Analysing

- 25 Discuss** whether population control would reduce global warming.

Evaluating

- 26** Many believe that the technology exists to produce cars that travel twice as far on each tank of fuel. Assuming that such technology does exist, **propose** reasons why such cars are not being manufactured.
- 27** Imagine that all greenhouse gas emissions stopped today. What impact would this have on concentrations of greenhouse gases in the atmosphere? **Justify** your answer.
- 28** Given adequate rainfall and suitable temperatures, wheat yields may actually increase in response to higher CO₂ concentrations. **Assess** why.

Creating

- 29 Construct** a pie chart showing Australian production of greenhouse gases. **N**
- 30** Carbon dioxide emissions per person for several countries are listed below.
- a Construct** a column graph showing this information. **N**
- b** Use these figures to **deduce** which countries produce the most or least carbon dioxide per person.

Country	Carbon dioxide emissions per capita, 2003 (tonnes per 1000 people)
Australia	18.9
United States	19.8
Canada	16.2
New Zealand	8.3
Germany	10.2
United Kingdom	9.3
Japan	9.6

8.2 INVESTIGATING

Investigate your available resources (for example, textbooks, encyclopaedias, internet) to complete the following tasks.

- Find out about the climate projections of organisations like the CSIRO and the United States Environment Protection Agency. Construct a poster that summarises their findings. **L**
- a** Find out about the Kyoto Protocol. Summarise Australia's position on this in the past and its contribution in the present day.

b Write a letter to the government arguing whether or not Australia should have joined the Kyoto Protocol. Back your argument with as much evidence as possible.
- Construct a map showing the countries or islands most at risk of partially or totally disappearing due to rises in sea levels.
- a** Compare El Niño, La Niña and the North Atlantic Oscillation (NAO).

- b** Explain how each of these is thought to be linked to global warming.
- c** Evaluate the impact of these phenomena on the Australian climate.

e-xploring

To use the Australian Greenhouse Calculator and **investigate** the household gas emissions in your house, a list of web destinations can be found on **Science Focus 4 Second Edition Student Lounge**.

- Complete the investigation and write a report including bar graphs to show your household emissions compared to 'green' and 'typical' household usage.
- Recommend actions that can reduce your greenhouse gas emissions.



8.2 PRACTICAL ACTIVITIES

1 The greenhouse effect

Aim

To simulate the conditions required for the greenhouse effect

Equipment

- small cardboard box (e.g. a shoebox)
- 2 thermometers or temperature probes and datalogging equipment
- sheet of glass or polythene plastic
- lamp

Method

- 1 Assemble the apparatus as shown in Figure 8.2.14.
- 2 Turn on the lamp and measure the temperature at regular intervals (e.g. every minute) for 10 minutes.
- 3 Turn off the lamp, but continue to measure temperature for another 10 minutes.
- 4 If time permits, investigate the effect of an additional layer of glass or plastic.

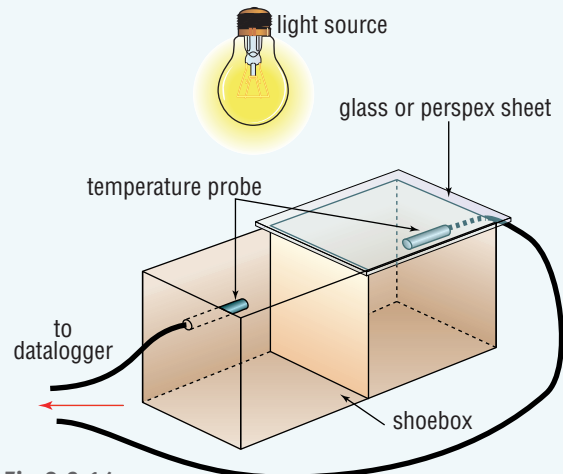

Fig 8.2.14

Questions

- 1 **Construct** a graph showing temperature versus time for each section of the box.
- 2 **Summarise** any differences in the temperature patterns in each section.
- 3 **Describe** what takes the place of the glass or plastic sheet in the global greenhouse effect.
- 4 **Identify** what adding another layer of glass or plastic represents if modelling the Earth.

2 Icebergs

Aim

To investigate the effect of melting ice on water levels

Equipment

- ice cubes (4–6)
- cold water
- beaker
- another identical beaker containing frozen water as shown in Figure 8.1.15

Method

- 1 Place some ice cubes (representing icebergs) in the empty beaker.
- 2 Add the same amount of water to each of the two beakers and mark the water level on the outside of each beaker.
- 3 Allow each beaker to warm enough so a significant amount of ice melts in each.

- 4 Compare the water level to that initially marked on each beaker.

Questions

- 1 **Deduce** whether the melting of floating icebergs contributes to a rise in sea levels.
- 2 **Deduce** whether the melting of 'land ice' contributes to a rise in sea levels.

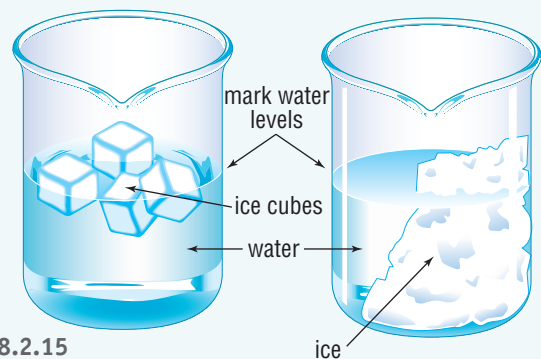

Fig 8.2.15

context

The world relies on fossil fuels for the bulk of its power and they are likely to run out in the next 50 years if they continue to be used at current rates. They also release the greenhouse gas carbon dioxide into the atmosphere which evidence suggests is probably changing our climate. Nuclear energy is

an alternative energy source to fossil fuels. It's clean and releases no greenhouse gases in its production. It does, however, produce wastes that remain lethal for thousands to millions of years. Although rare, accidents involving nuclear power are devastating and the damage often irreparable.

Why nuclear?

Many countries have invested heavily in **nuclear power**. Australia has no nuclear power stations, but after Canada, it is the biggest supplier of uranium for nuclear power stations. Although nuclear power is not a renewable resource, it provides vast amounts of energy from a small amount of fuel. For example, one kilogram of uranium ore can produce as much energy as 100 kilograms of coal and with far less of the greenhouse gas, carbon dioxide. However, the full cost of nuclear power must be considered. Nuclear power stations use non-renewable energy, such as electricity, to set up. Nuclear energy also comes with the problem of how to dispose of the dangerous waste products.

Generating nuclear energy

Fission

When **uranium-235** absorbs a neutron, it becomes extremely unstable. Instead of emitting an alpha or beta particle or a gamma ray, the uranium-235 isotope splits into two smaller atoms along with two or three neutrons. Heat energy is released in the process. The splitting of an atom is called **fission**. Lone or 'stray' neutrons are produced this way in the atmosphere by cosmic rays.

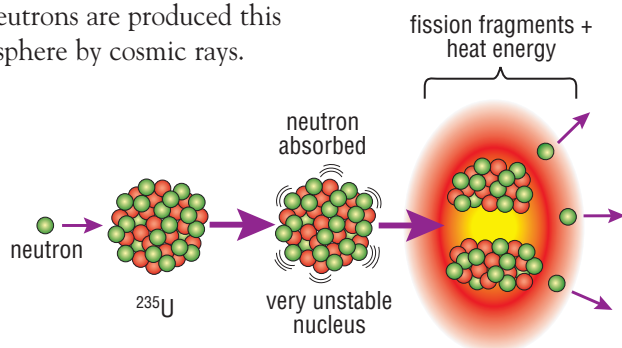

Fig 8.3.2 Nuclear fission



Fig 8.3.1 A nuclear power station and its cooling towers

Science Clip

Comparing wastes

The average Australian consumption of electrical energy is about 8000 kilowatt hours per home every year. To generate this much electricity, 3000 kg of black coal is required. This produces wastes of up to 500 kg of ash as well as 8000 kg of carbon dioxide and sulfur dioxide—enough to fill three Olympic-sized swimming pools. In comparison, only 30 to 70 kg of uranium ore is required to generate the same amount of electricity, producing just 0.006 kg or 6 grams of highly radioactive waste.

Science
Fact File

$E = mc^2$

Albert Einstein's famous equation is often quoted, but what does it really mean?

In normal chemical reactions, mass always stays the same. Not so in nuclear fission, however! During nuclear fission, there is a slight loss of mass. Einstein found that this lost mass is converted to energy, and that the amount of energy created (E) is equal to the lost mass (m) multiplied by the speed of light (c) squared. Although only around 0.1% of each tiny nuclear mass is converted to energy, the energy released quickly builds up due to the incredibly large number of atoms in any radioactive sample (1 gram of uranium-235 contains 2.5 billion trillion atoms!), and the fact that the speed of light equals 300 000 000 metres per second.

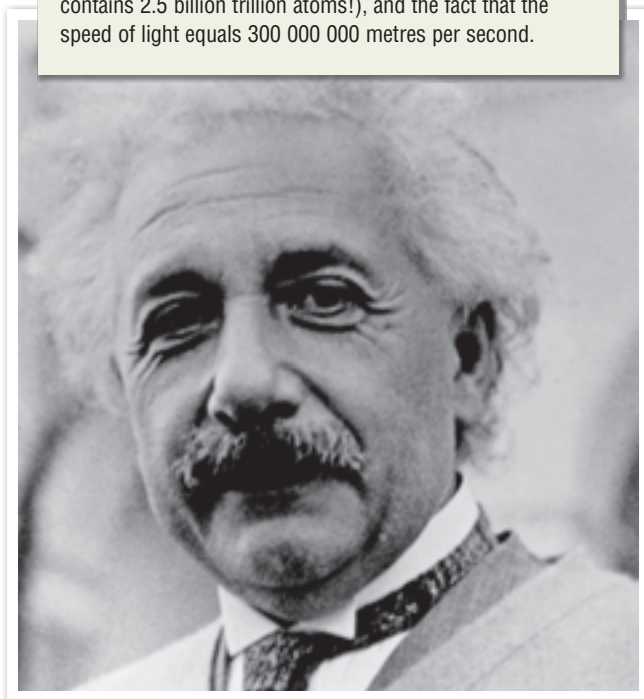

Fig 8.3.3 Einstein predicted that nuclear energy could be calculated using the equation $E = mc^2$. This equation allowed scientists to unlock the power in the nucleus.

Chain reaction

Normally, the extra neutrons released by the fission of uranium-235 escape the sample or are absorbed by the more stable and more numerous uranium-238 atoms (natural uranium contains only about 0.7 per cent uranium-235).

A chain reaction will occur, however, if these neutrons strike other uranium-235 atoms. This causes more fission and more neutrons, which then hit more uranium-235 atoms, which then release even more neutrons ... and so it goes on and on. Huge amounts of energy are released in a fraction of a second. For a chain reaction to 'take off', the

uranium sample needs careful preparation by either:

- enriching it so that it contains 2.5 per cent or more uranium-235
- forming it into a shape to prevent too many neutrons escaping without first interacting with other atoms (spherical is good)
- making it large enough (the required mass is called the critical mass).

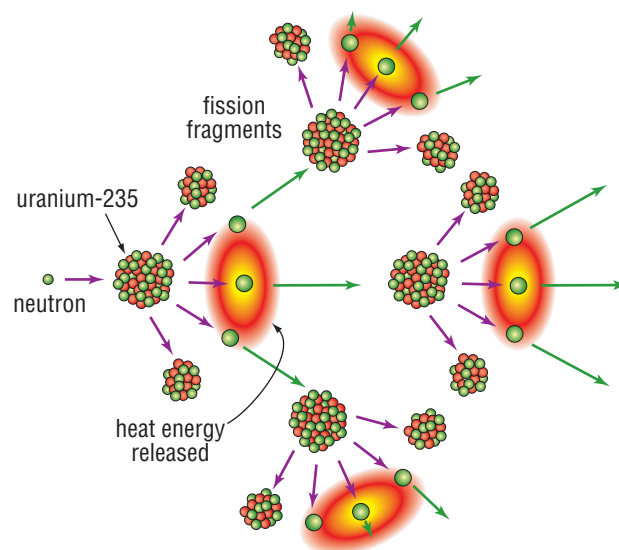

Fig 8.3.4 A fission chain reaction

Nuclear bombs

A nuclear bomb uses uranium enriched so that over 90 per cent of the sample will be uranium-235. The result is a massive, uncontrolled chain reaction. The bomb dropped on the Japanese city of Hiroshima in 1945 contained two half-spheres of 90 per cent pure uranium-235.

Each piece was smaller than the critical mass needed for a chain reaction, but when forced together by an explosive charge, they formed a supercritical mass which then exploded.

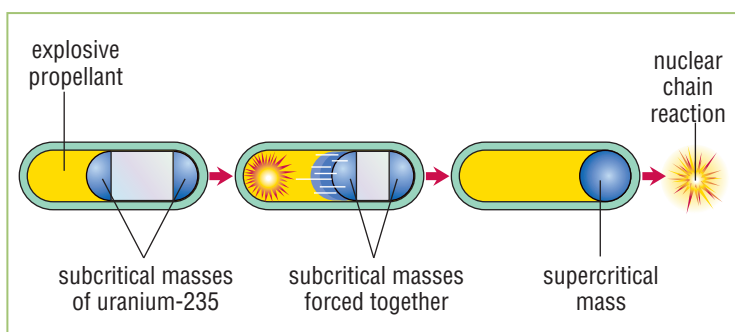

Fig 8.3.5 A nuclear bomb explodes because the mass of uranium becomes supercritical.

Nuclear reactors

A **nuclear reactor** is like a controlled nuclear bomb, but uses uranium that has been enriched to about 2.5 per cent uranium-235. To prevent an uncontrolled chain reaction, control rods made of neutron-absorbing boron or cadmium are used to 'soak up' neutrons so that on average only one escapes from each fission to go on to cause another fission.

Heat generated in a reactor core by nuclear fission is used to generate steam, which spins a turbine and produces electricity in the same way as conventional electricity generators.

Nuclear reactors currently provide around 17 per cent of the world's electricity. Several countries, such as Sweden, obtain about half their electricity from nuclear power plants (see table). Submarines and space probes often use on-board nuclear reactors.

Australia's only nuclear reactor—the HIFAR reactor at ANSTO in southern Sydney—is a small reactor used for the production of nuclear medicines.

Nuclear dangers

Nuclear power at one time seemed like the answer to the world's energy needs, but the initial enthusiasm has been tempered by a series of accidents and the problem of how to safely store the deadly waste products. In addition, energy from coal and gas is used to set up

Country	Percentage of electricity generated by nuclear power plants
Australia	0
Britain	21
United States	22
Japan	24
South Korea	48
Sweden	52
France	73

nuclear power stations. All these factors are costs and risks that must be considered when deciding whether nuclear power is a viable option.

Nuclear accidents

Radiation accidents that are limited in scale occur regularly in nuclear power stations around the world. There have been several well-documented accidents at nuclear power plants in which radiation has been released into the environment. The most serious of these occurred at Chernobyl in the Ukraine (then part of the Soviet Union, now an independent country) in 1986. Many clean-up workers, photographers and their

Fig 8.3.6 A nuclear reactor, showing its main components

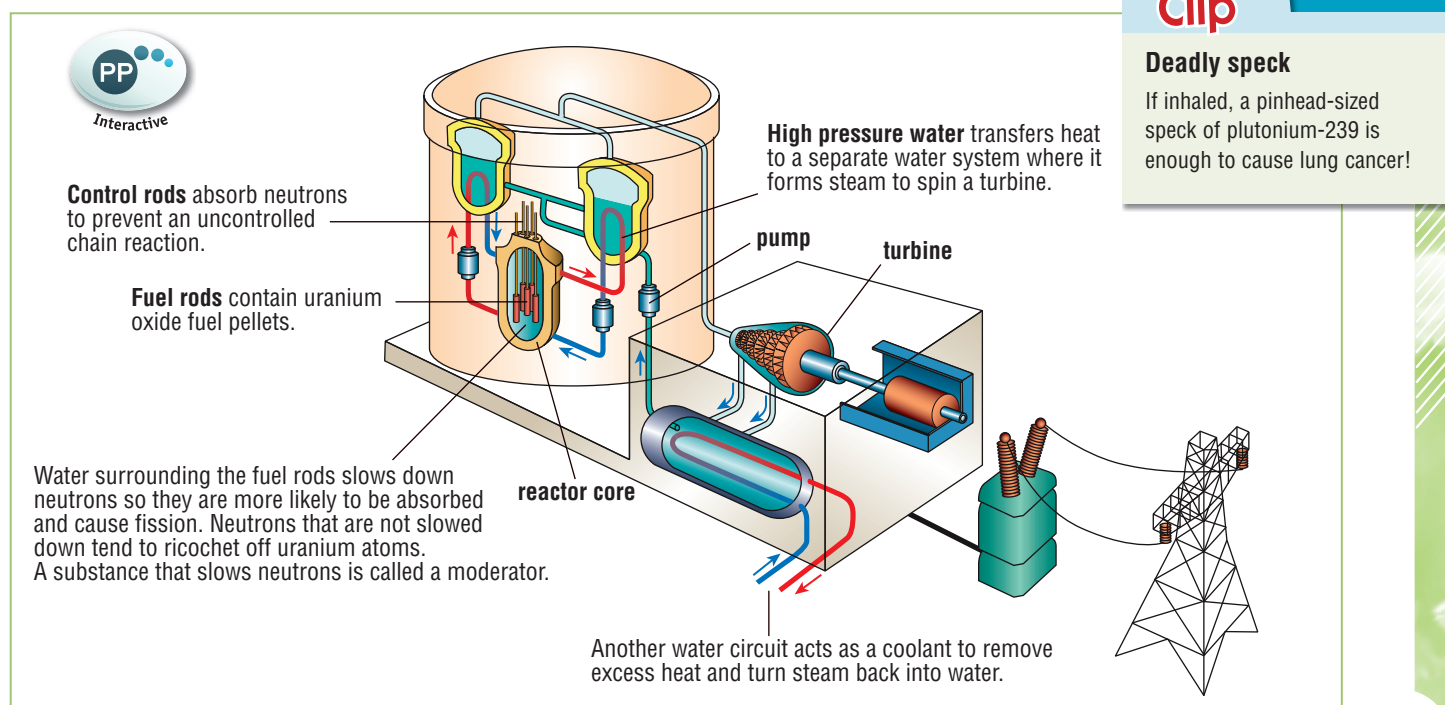



Fig 8.3.7 Australia's nuclear research reactor at (ANSTO) the Australian Nuclear Science and Technology Organisation

pilots died in the years after the accident from cancers caused by massive doses of radiation received as they worked around the devastation.

At the time of the accident, a five-kilometre-high plume of debris released more radioactivity into the atmosphere than 100 Hiroshima bombs. The explosion started a fire that burned for five days. There were 31 immediate casualties. Nearby Belarus was downwind of Chernobyl and much of it remains uninhabitable. Cancer rates there have also risen dramatically and the long-term toll may reach many thousands. A gigantic concrete structure called a sarcophagus was built around the damaged reactor to help contain the radiation, although this structure is now decaying and needs replacement.

Nuclear waste disposal

Nuclear waste is classified into three levels.

- **Low-level waste** does not require a great deal of protective covering and includes things like air filters and gloves used by people such as nuclear power plant workers and hospital staff who handle radioactive substances. Low-level waste may be incinerated, stored in strong containers or buried at special sites.
- **Intermediate-level waste** is more radioactive and includes things like reactor parts. It is typically packaged inside cement within steel drums and buried in deep trenches.

- **High-level waste** is lethal and consists of waste from either used fuel rods or generated from reprocessing the rods to obtain uranium and plutonium. Used fuel rods are stored under water for several years while they cool and their radiation levels drop before being reprocessed or disposed of. High-level waste is melted to form glass blocks and may be stored underground in stainless steel drums.



Fig 8.3.8 Measuring radiation levels in a primary school near Chernobyl, 20 years after the accident

Science Clip

Radioactive coal

A coal-fired generator releases more radioactivity into the environment than a nuclear power station—unless there's an accident in the nuclear power station!

Science Fact File

Maralinga meltdown

Between 1952 and 1957, the British Government conducted a series of tests, setting off 12 major nuclear explosions and hundreds of smaller ones at Maralinga in South Australia. This forced the relocation of the local Aboriginal people. Britain assured Australia that it had cleaned up the Maralinga site by 1967. In 1984, when Australian scientists measured the radiation, they found it was more widely spread and at levels 10 times higher than predicted. The clean-up of the site was finally completed in 2000 with financial contributions from Britain. One process used in the clean-up, in-situ vitrification (ISV), involved generators providing up to 5 megawatts of power to electrodes implanted in nuclear waste pits to melt waste into huge glassy masses. This prevents nuclear waste from leaching into surrounding soil and eliminates the need for excavation or removal of hazardous material.



Fig 8.3.9 There was a nuclear explosion at Maralinga in South Australia in 1956. Dangerous levels of radioactivity remain.



Fig 8.3.10 Four giant electrodes can be seen at the top of the in-situ vitrification equipment. The large pipe connected to the truck channels exhaust gases from the melt for analysis.

Two sides of the story

Because nuclear waste products can remain radioactive for many thousands of years (the half-life of plutonium is 24 000 years), there is plenty of time for something to go wrong. Deterioration of storage containers or natural disasters could both cause leakage into the environment. Many people argue that the consequences of potential accidents involving nuclear waste or nuclear power plants are just not worth the risk. Others argue that damage being done to the environment (e.g. pollution and global warming) from the use of fossil fuels is greater than that resulting from the use of nuclear energy. Coal miners suffer more ill health as a result of their work than nuclear workers. Oil spills from supertankers regularly kill huge numbers of marine and bird life. The risks associated with both fossil fuels and nuclear power must be considered.

Australia also needs to consider its involvement in dealing with nuclear waste. Australia supplies much of the world's uranium, and should therefore be responsible for helping to deal with the waste produced. Australian uranium is used for illicit purposes such as nuclear weapons and this issue should also be considered.



Worksheet 8.4 Nuclear devastation

Alternative energy sources

There are many alternatives to fossil fuels and nuclear energy that can meet our energy needs.

Fusion

One of these alternative energy sources is in fact another form of nuclear energy! **Nuclear fusion** is when two small nuclei combine or fuse, releasing an enormous amount of energy as they do so. An example of nuclear fusion is the combination of a deuterium nucleus and a tritium nucleus to form helium.

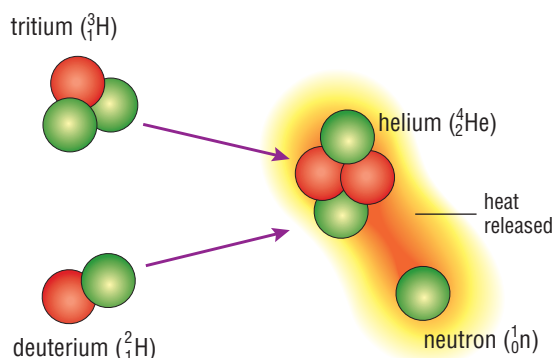

Fig 8.3.11 A nuclear fusion reaction

Nuclear fusion has a couple of advantages:

- no radioactive waste products are created
- there is a vast supply of deuterium in the ocean.

However, temperatures of millions of degrees are needed to force two positively charged nuclei together and to keep the process going. It is nuclear fusion reactions that power the Sun. Even if sustained fusion reactions could be generated, the problem remains of how it could be contained.

Current research involves the use of a powerful toroidal (doughnut-shaped) magnetic field within a device called a tokamak to hold the superheated deuterium. The word 'tokamak' is from the Russian word for toroidal. If the costs and difficulties involved in sustained fusion generators are overcome, fusion may provide the bulk of the world's energy in the future.

Other alternatives

Other alternative sources of energy that offer potential for the future include:

- solar
- wind
- hydro-gravitational wave or tidal
- geothermal
- fuel cells
- bio-batteries.

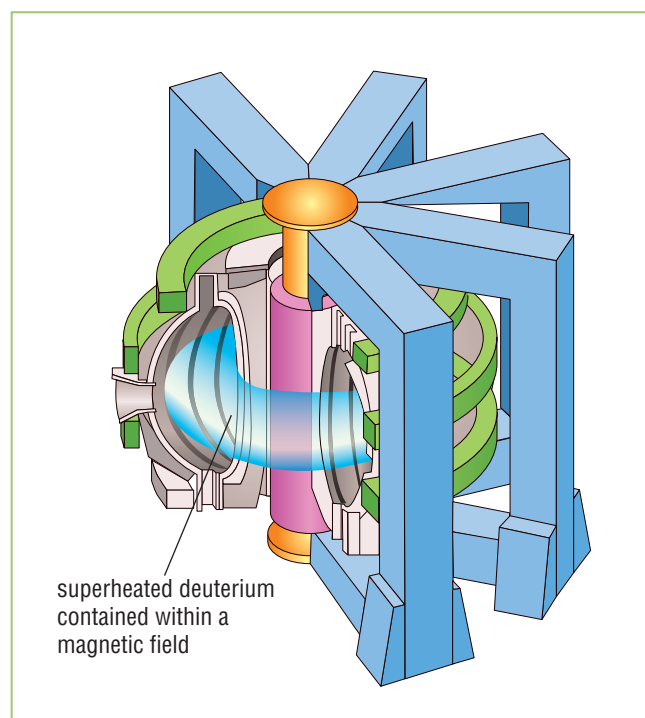

Fig 8.3.12 An experimental tokamak fusion reactor

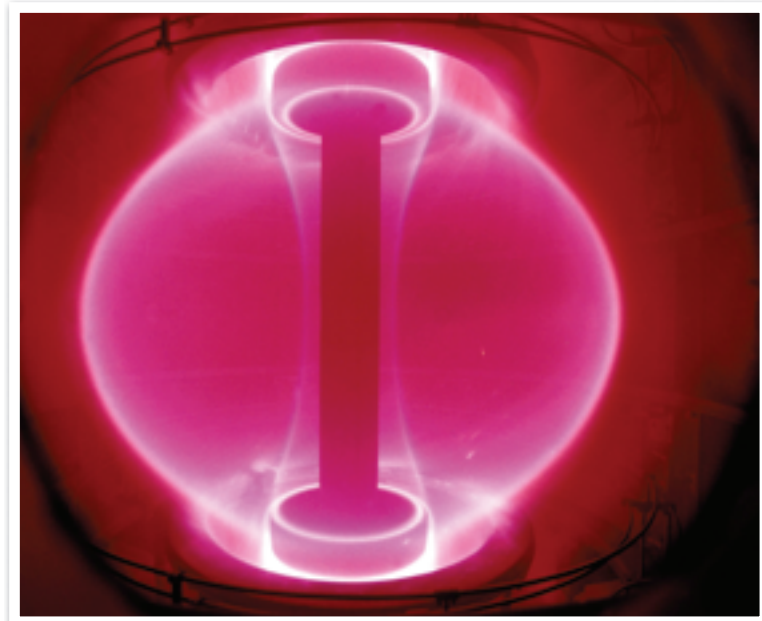

Fig 8.3.13 Spherical ball of plasma (pink) inside a tokamak

8.3 QUESTIONS

Remembering

- 1 **State** what nuclear fission is.
- 2 **State** the main advantage of nuclear fusion.
- 3 **List** three types of renewable energy sources.

Understanding

- 4 **Use** a diagram to explain the term 'nuclear fission'.
- 5 In a chain reaction, huge quantities of energy are released. **Outline** how this happens.
- 6 **Describe** how a nuclear bomb works.
- 7 **Describe** how an uncontrolled chain reaction is prevented in a nuclear reactor.
- 8 **Describe** two dangers of using nuclear energy.
- 9 **Outline** how high-level nuclear waste is stored.
- 10 There are risks involved in storing nuclear waste. **Describe** some of these risks.
- 11 **Explain** why using nuclear fusion is technically difficult.
- 12 Copy and **modify** any incorrect statements to make them true.
 - a Uranium provides much more energy per kilogram than coal.
 - b Unstable atoms absorb radiation.
 - c Natural uranium contains 93% uranium-235.
 - d A critical mass of uranium-235 is one that will not start a chain reaction.
 - e Fission is the splitting of an atom.
 - f One type of fusion reactor is a tomahawk.
- 13 **Explain** why Australia has a nuclear reactor if it does not use nuclear power to produce electricity.
- 14 **Propose** a meaning for the term 'magnetic bottle'.
- 15 **Predict** whether waste plutonium would be safe in:
 - a 100 years
 - b 1000 years
 - c 10 000 years
- 16 **Explain** how fallout from the Chernobyl accident could result in children drinking radioactive milk.

- 17 **Explain** why the air pressure inside nuclear reactors is kept lower than the outside atmospheric pressure.
- 18 **Discuss** whether Australia should be investing in nuclear power or other alternative energy sources for the future.

Applying

- 19 **Identify** two countries that would be most affected if uranium was no longer mined and processed.
- 20 Nuclear fission reactors produce lots of energy. **Identify** three situations where a nuclear reactor may be used.
- 21 **Identify** which part of a nuclear reactor:
 - a slows down neutrons to speeds at which they are more likely to cause fission
 - b absorbs neutrons to prevent them causing other atoms to split
 - c transfers energy to a turbine
- 22 Use a diagram to **demonstrate** how nuclear fusion occurs.
- 23 With the aid of diagrams, **demonstrate** why a sphere is a more effective shape than a flat sheet for a critical mass of enriched uranium.

Analysing

- 24 **Compare** a nuclear bomb with a nuclear reactor.
- 25 **Classify** each of the following as low-, intermediate- or high-level nuclear waste:
 - a spent fuel rods
 - b gloves used by nuclear reactor technicians
 - c a non-fuel-rod reactor part

Evaluating

- 26 The following questions relate to the Chernobyl nuclear accident.
 - a **Propose** ways in which the disaster could have been prevented.
 - b **Propose** how Swedish scientists became aware of a nuclear accident in Russia.
 - c The likely death toll will be far greater than the initial 31 people killed. **Explain** why.

Creating

- 27** Some people have suggested that outback Australia (even the interior of Uluru) be used as a long-term storage site for the world's nuclear waste. This is because of the area's geological stability. Write two letters/emails to a newspaper to **construct** an argument—one supporting and one opposing the proposal.
- 28** Write an essay describing life in the future when reserves of fossil fuels finally run out. You must **construct** four different 'endings' that are based on the following scenarios:
- the world becomes totally reliant on nuclear energy
 - both fossil fuels and uranium reserves run out, and the world concentrates on the development of renewable energy sources such as wind, wave and solar energy
 - nuclear fusion technology improves to the point where fusion reactors become the most economical source of energy
 - a totally new and plentiful energy source is discovered.

8.3 INVESTIGATING

Investigate your available resources (for example, textbooks, encyclopaedias, internet) to complete the following tasks.

- 1** Find out about alternative energy sources apart from nuclear power. Select one source and:
 - a** describe how energy is produced in this way
 - b** assess the efficiency of this energy source
 - c** outline the advantages and disadvantages of your alternative energy source
 - d** evaluate whether this energy source would be suitable for use in the future
 - e** present your information as an oral presentation.
- 2** Research a significant nuclear accident such as Chernobyl, the Three Mile Island disaster in the United States or the leak at Britain's Windscale (now called Sellafield) plant. Propose a set of safety rules that would prevent this type of accident in the future.
- 3** Find out about so-called 'fast breeder' nuclear reactors which use plutonium and produce more fuel than they consume. Use chemical equations to demonstrate how this is achieved.
- 4** Research an Australian invention called SYNROC designed to store radioactive waste. Use a diagram to explain how the waste is stored.
- 5** Construct a poster that shows where uranium is mined in Australia and the steps in the process needed to produce 'yellowcake'.

context

Food is one of the basic needs for all animals, including humans. Science and technology can affect food in both positive and negative ways.

Bioaccumulation

Very few organisms eat humans—but we eat a lot of organisms. Humans are the top of many food chains and food webs. Every poison (**toxin**) and pollutant that is stored in the flesh of a fish or animal or in the stems, fruit, or leaves of plants will be absorbed by us when we eat them. Being at the top of the food chain, humans tend to accumulate these toxins. Other large animals at the top of their food chain (such as sharks and polar bears) also tend to accumulate the toxins carried by the living things they eat. This intake of toxins is called **bioaccumulation**. Each level of the food chain has more toxin than the level below it. This is because, for example, one small fish will eat many smaller fish or tiny shrimp-like plankton. Likewise, a larger fish will eat many small fish, and a shark will eat many large fish. The concentrations of toxins are **biomagnified**.

Although many of the absorbed toxins will be excreted out in urine, sweat or faeces, some will stay in the body. Others may be secreted at a lesser rate than they are being absorbed. Over the years these toxins will build and build in the body until they finally get to a concentration where they severely interfere with its function. This is referred to as **bioconcentration**.

Go to  Science Focus 4 Unit 4.5

Sources of bioaccumulation

The toxins that enter food chains come from a number of sources:

- industrial pollution, particularly water pollution (e.g. mercury, arsenic, cadmium and dioxins)
- exhaust gases from cars and trucks (e.g. lead)
- pesticides and herbicides used in farms, orchards and market-gardens (e.g. DDT).

Although industrial pollution in Australia is tightly controlled and monitored, industry still releases some toxins into the food chains, particularly those of organisms that live in water or depend on water-based creatures as a food source.



Fig 8.4.1 Genetically engineered square tomatoes could be a reality in the future, allowing them to be stacked and sliced more easily than 'normal' round ones.

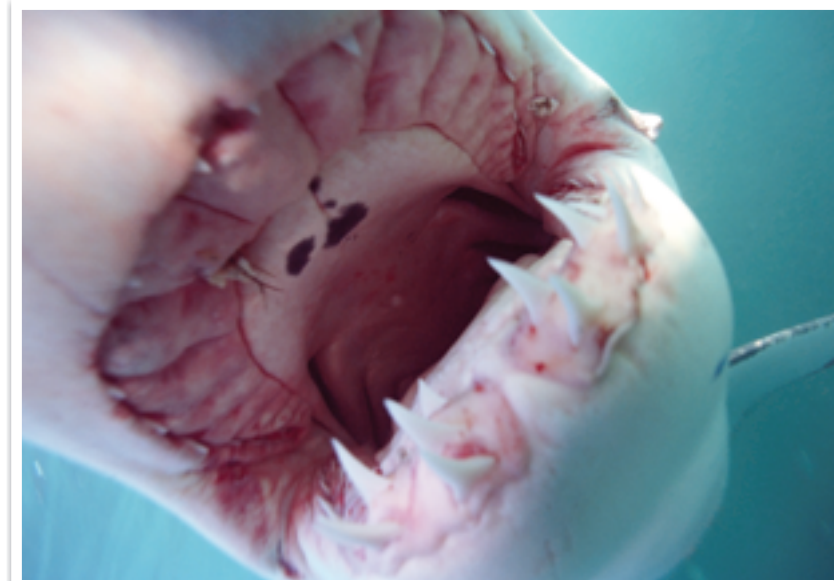

Fig 8.4.2 Sharks are often the top of the food chain and humans sometimes end up as their food. There are, however, only five fatal shark attacks on average each year worldwide. The odds of winning Lotto are far higher than those of being bitten by a shark. On the other hand, humans eat about 100 million sharks each year.



Fig 8.4.3 Herbicides and pesticides can enter the food chain via spraying as is happening in this orchard.

All of the following chemicals were thought at one stage to be wonder-chemicals or a necessary part of industrialisation. A study of these chemicals shows how the human race must be careful with whatever chemicals we use and dispose of.

Mercury

In the past, the metallic element mercury (Hg) was commonly released in industrial effluents. Very little of it is released in effluent today, although some mercury is still released in the production of gold, cement, batteries and steel. It is also released into the air whenever coal is burnt. Mercury soon forms methyl mercury after its release. This organic compound dissolves in fats and tends to bioaccumulate in the brain, causing mercury poisoning and permanent damage to the central

nervous system. Common symptoms are a lack of coordination, reduced vision, hearing and speech. At extreme levels, mercury poisoning can lead to psychotic episodes such as hallucinations. In children it has been shown to impair attention, memory and intelligence.

Lead

Cars used to burn 'leaded' petrol with one of its components—a compound called tetra-ethyl lead that contains the metallic element lead (element symbol Pb). This lead was released in the car's exhaust. It could be breathed in directly or fall to the ground. There it would stay until wind or passing traffic threw it back up into the air to be breathed in again. For these reasons, all new cars now must use unleaded petrol or some other lead-free alternative like diesel or LPG.

Some old paints also used to contain lead. If this paint began to peel or chip or was sanded, this lead was released into the air.

Like mercury, lead is fat-soluble and so can bioaccumulate in the body where it primarily affects the central nervous system. Common symptoms of lead poisoning are headache, irritability, insomnia and a loss of logic when tackling problems that were once easy. Prolonged exposure also adversely affects the digestive system (e.g. diarrhoea, vomiting, severe weight loss) and

Science Clip

Toxic Barbie

In 2007, toymakers Mattel and Fisher-Price recalled a total of 10.5 million of their toys. Against regulations set by both companies, some factories in China had used toxic lead-based paints on many of these toys. Small children often chew on their toys, ingesting any lead in the paint. Lead has a greater affect on developing children than on adults.

Science Clip

Mad as a hatter

The Mad Hatter from the book *Alice in Wonderland* was 'mad' for a very good reason. Top hats were made from felt, which needed to be stiffened with mercury. Hatters (the people who made hats) often breathed in so much mercury that they became 'mad'. For this reason, mercury should never be exposed to the air or skin in the laboratory.



Fig 8.4.4 The Mad Hatter

Science Clip

Sharks can be dangerous!

The flake sold in fish shops is shark. Sharks sit at or near the top of the food chain and so they tend to bioaccumulate a lot of chemicals, particularly mercury. Mercury is known to affect the brain and therefore eating it is a concern. In Australia, mercury levels in sharks were so high in the 1960s that limits were placed on the size of sharks caught for flake: large sharks were older ones that had probably accumulated higher levels of mercury than smaller, younger ones. Large fish such as tuna and swordfish also commonly have high levels of mercury.

Science Clip

Toxic Melbourne

Melbourne's main ports are located in notoriously shallow Port Phillip Bay and the Yarra River. Although current container vessels can visit, the newer ones will not. For this reason, in 2008 a massive dredge began to deepen the shipping lanes leading to the ports. Many fear that this severe dredging will release 100 years of toxins such as mercury and dioxins into the Port Phillip Bay food chains.

Science Clip

Political dioxin poisoning

Victor Yushchenko was campaigning for the presidency of the Ukraine in 2004 when he suddenly fell ill with suspected food poisoning. Five days later he developed lesions and ulcers on his face, chest, stomach and throughout his digestive tract. Blood tests showed incredibly high levels of dioxin in his blood. It is alleged that he was deliberately poisoned to stop him becoming President. He eventually won the election and became President in 2005.



Fig 8.4.5 Victor Yushchenko before and after being deliberately poisoned with dioxins

gives rise to learning disabilities, stunted growth and possibly mental retardation in children.

Dioxins

Dioxins are a family of organic compounds that are fat soluble. This allows them to easily enter the bodies of fish, animals and humans. Although minute quantities of dioxins are present in cigarette smoke, plastics and even tampons, the main source of dioxins for humans is via their food. Dioxins

bioaccumulate and are thought to be **carcinogens** (cancer-causing agents). They can also affect the immune and reproductive systems.

Dioxins are released from a number of industrial processes such as metal smelting and the bleaching of paper and fibres. In late 2007, a massive new pulp mill was approved for the Tamar Valley north of Launceston in Tasmania. Pulp mills make and bleach paper and so this mill will release small quantities of dioxins into the river that will eventually enter Bass Strait. For this and other reasons, many people objected to it being built.

Herbicides and pesticides

Herbicides are chemicals that kill weeds while **pesticides** kill pest insects. They have been widely used on farms, market gardens and orchards to maximise the quantity and quality of the crops produced. Although these chemicals do their job well, they are also absorbed into the sprayed plants. Anything that eats those plants, or the seed, vegetables or fruit they produce, will also ingest these toxic chemicals.

DDT

DDT (dichloro-diphenyl-trichloroethane) was once a very effective pesticide. Although it was developed in 1874, no-one knew what to do with it until 1938. World War II started soon after, and allied troops began to use DDT to kill mosquitoes (and their infectious payloads of malaria and typhus), lice and biting midges. In 1955, the World Health Organization (WHO) began a DDT spraying program in a worldwide attempt to eradicate malaria-carrying mosquitoes.

Over the years, DDT bioaccumulation has caused:

- the development of DDT-resistant mosquitoes
- the thinning of shells in the eggs of the American bald eagle, ospreys and other fish-eating birds, reducing their numbers to endangered levels because their eggs broke before hatching
- changes in the ratios of males and females in certain bird populations, with less males than ever being born.

The use and production of DDT is now banned in most western countries such as Australia, the United States and those in Europe. Many countries are, however, still producing and using DDT, mainly to control mosquitoes.



Fig 8.4.6 In the 1950s and 1960s, suburbs, beaches (and people) were sprayed with DDT to control insects such as mosquitoes and lice.

The blue-green pest

Blue-green algae are poisonous aquatic plants that often take over lakes, dams and slow-flowing rivers and tidal estuaries throughout Australia. Depending on the amount of light and nutrients, they will float on the top of the water as a visible algal 'bloom' or will drop to the bottom. Blue-green algae are toxic to humans and animals: when touched they can cause symptoms from skin rashes and itchiness to asthma and swollen lips. If water containing them is drunk, symptoms can range from headache and muscle weakness to pneumonia and paralysis. Laboratory tests have even shown that they can promote tumours of the skin, liver and gut.

Yabbies and crayfish living in the affected water absorb the toxins that blue-green algae produce. Filter-feeders such as mussels are even more affected.

The toxins accumulate in these shellfish and in anything that eats them. Around the world, many humans have died from the **PSP toxin** (paralytic shellfish poisoning toxin) found in affected shellfish. Government authorities recommend that no shellfish are eaten from waters infested with blue-green algae. Fish are affected by bioaccumulation of blue-green algae toxins but research so far has suggested that the toxins concentrate in their digestive tracts and livers, which are not eaten by humans.

Although a naturally occurring organism, outbreaks of blue-green algae are most likely due to pollution, mainly phosphorus and nitrogen (the main elements in many fertilisers) running off from farmland. Warm weather then encourages their growth.

Genetic modification of food

For thousands of years humans have changed the genetic information of the plants and animals they cultivate through **selective breeding**. The huge number of different sizes and shapes of dogs that exist today were all developed from a wolf-like ancestor species through selective breeding. Similarly, most vegetables and other crops produce more and better fruit than their ancestors through careful selective breeding over centuries.

In recent years, new techniques in **gene technology** (extracting, rearranging and reinserting genetic material in cells) has allowed scientists to change the characteristics of species much more quickly and in much more specific ways. The genetic information of an organism is stored in the DNA in its cells. It is now possible to add and remove genes to the DNA of plants and animals. It is even possible to use genes from different species— for example, to add a fish gene to a vegetable. Organisms (plants, animals and bacteria) to which this has been done are usually referred to as **GMOs (genetically modified organisms)**.

Go to  Science Focus 4 Unit 3.4

Reasons for genetic modification

Selective breeding has been used to increase yields, to breed stronger and hardier, more drought-resistant plants, and to breed for pest and disease resistance. Genetic modification is used for the same reasons, and can increase the yields from existing farms, market gardens and orchards. This can potentially help feed an

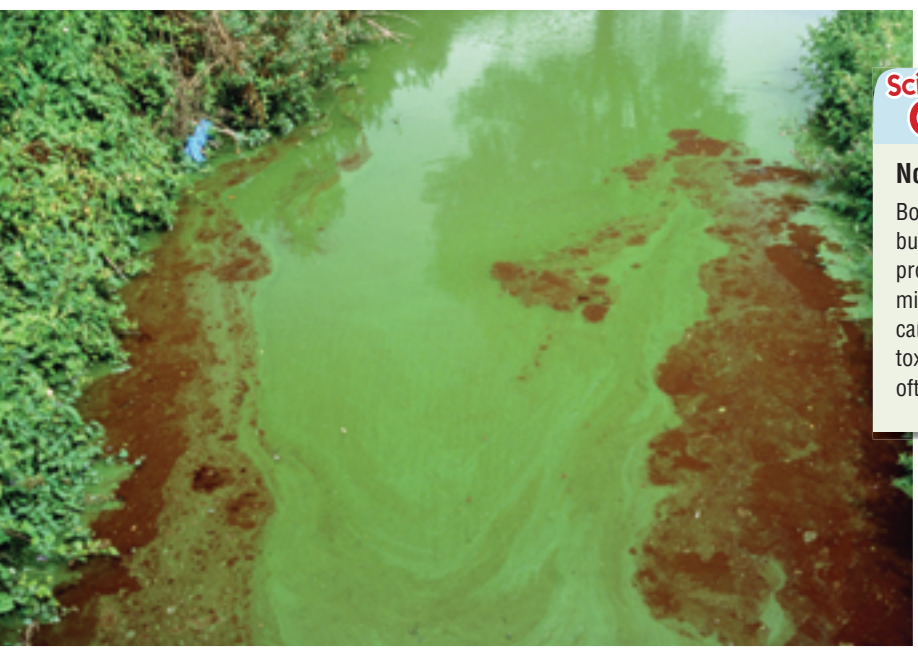

Science Clip

No protection!

Boiling water normally kills the pests in blue-green algae but it does not destroy the chemical toxins that it produces. It has also been shown that wearing a wetsuit might make the situation worse for the wearer: the algae can get trapped against the skin making absorption of the toxins more likely! Dogs that swim in infected water are often victims as they usually lick their coats afterwards.

Fig 8.4.7 A river seriously affected by a bloom of blue-green algae. Blue-green algae might be blue-green but it can also be red, brown, dark green or black!

increasingly overpopulated world. GMOs can be developed so that they taste bad or are poisonous to the pests that usually eat them, or so that they are immune to the herbicides that are used to kill weeds that would otherwise grow among them. Genetically modified animals can yield leaner, healthier meat and be less susceptible to disease.

Who owns GMOs?

The plants that make up genetically modified crops are often made sterile—that is, the seeds they produce will not germinate nor can they be used to grow new crops. This is intentional because scientists are worried about genetically modified crops escaping into the environment and overrunning indigenous plants. It raises another issue, however: farmers cannot save seeds from one year's crop to plant the next year, which is a practice that has been part of farming ever since humans first began cultivating crops thousands of years ago. Instead, they have to buy more seeds each year, increasing their production costs and passing control of much of the world's food supply to a few companies.

There have also been cases, particularly in Canada, where companies have sued farmers, claiming the farmers used their patented GMO-plants without permission. The farmers claimed that they had not used seeds from the company, and that instead the GMO had spread into their crops and 'polluted' them. Complex legal and ethical issues arise when an individual or company 'owns' a particular set of genes or a particular strain of plant.

GMOs in food

Many people worry about eating food products that are derived from GMOs. They worry that:

- the plant proteins in GMOs might be different from those in naturally bred plants
- genes from other species might have been introduced into the GMOs. Religions such as Judaism and Islam, for example, forbid the eating of pigs. What would their response be if a pig gene was inserted into a potato to give it some desirable characteristic? Likewise, would vegetarians and vegans eat the potatoes?

- digestion in the body might absorb the inserted genes. They may then insert themselves into the DNA of those who eat the GMOs.

Different food brings slightly different issues. While meat from genetically modified animals contains their DNA, sugar from GM sugarcane does not contain any of its DNA. Instead it is pure sucrose crystals. Although genetically modified cotton is used only for clothes and not for food, cottonseed oil is increasingly being used in cooking.



Fig 8.4.8 Canola is commonly processed into vegetable oils. Its pests need to be constantly sprayed, as do the weeds that try and choke it out. Genetically modified, pest- and herbicide-resistant canola can now be grown in NSW, Victoria and SA. It is likely it will also soon be grown in Tasmania and WA. Queensland's warmer climate makes much of it unsuitable for growing canola.



Fig 8.4.9 Activists in Sydney in 2007 protest against the imminent lifting of the moratorium on GM food crops in New South Wales



Fig 8.4.10 Genetically modified foods do not need to be labelled in Australia.

Several Australian states have legal moratoriums (bans) on growing and using GM crops such as canola for food. Three states, NSW, SA and Victoria lifted their moratoriums in late 2007 and it is possible that other states will also change their laws to allow GM foods to be produced and sold.

There is also a national *Gene Technology Act (2000)* and the Office of the Gene Technology Regulator (OGTR) serves to enforce the national laws on use of genetic technologies. Foods sold in Australia are currently required by Food Standards Australia New Zealand (FSANZ) to be labelled if they contain GMOs.

Reducing the food supply

Petrol prices have risen dramatically in recent years due to restricted supply and increasing demand, particularly in booming economies like China and India. To ease the reliance on petrol, many countries are actively developing biofuels. **Biofuels** are fuels (generally ethanol) that can be processed from crops such as sugarcane and corn.

Brazil has, for many years, converted much of its sugarcane crop into biofuel and most of its cars and trucks use it. In the United States, the Federal Government is financially assisting the production of biofuels from corn. This has reduced the amount of corn left for food. As a consequence, corn prices have increased. This price increase has had flow-on effects on the availability and price of some basic foodstuffs.

- Corn is a common winter food for animals in the United States and the meat prices have risen as corn prices have risen.
- United States corn is the main ingredient in tortillas, one of the major foods for the poor in Mexico. As corn prices rise, tortillas become less affordable to the people who most depend on them.
- Higher corn prices have encouraged many United States farmers to plant corn instead of their normal crops such as wheat and navy beans. As a result, navy bean prices have increased. Since navy beans are the main ingredient in baked beans, prices of this very basic foodstuff are expected to rise. Australia is not immune from these issues: because of the extended drought, Heinz and Ardana now import most of their navy beans from the United States and Canada.

In Europe, most biofuel is made from wheat, which is also the main ingredient of pasta. Pasta prices have risen as a result.

Poorer countries in Africa and Asia will be even more severely hit if the prices of basic foodstuffs rise because of biofuel.

Science Clip

The navy needs beans!

Navy beans are not called that because they are dark blue but because the entire crop went to the United States Navy during World War Two.

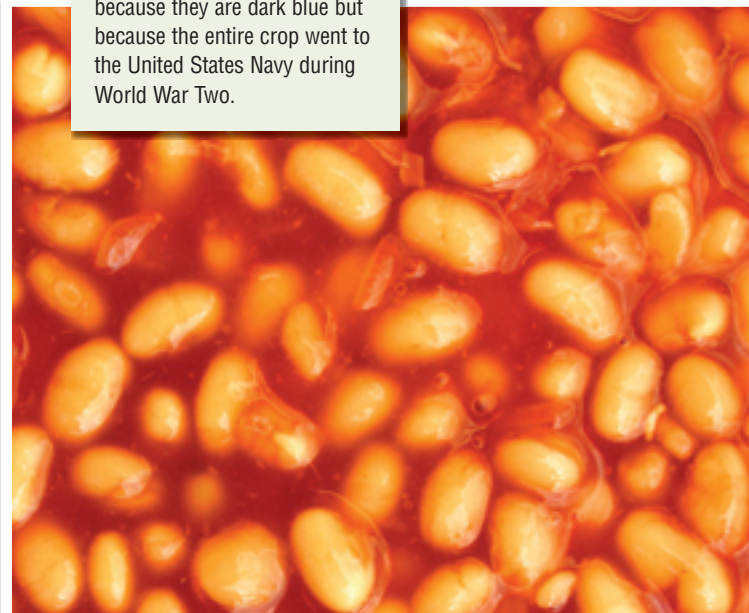

Figure 8.4.11 The prices of basic foodstuffs will increase because of farmland being used for biofuels instead of food.

8.4 QUESTIONS

Remembering

- 1 **List** three observed results of DDT bioaccumulation.
- 2 Besides petrol, **state** another source of lead being released into the environment.
- 3 **List** Victor Yushchenko's symptoms of dioxin poisoning.
- 4 **List** some of the benefits of DDT.
- 5 **List** the potential advantages of GM animals.
- 6 **List** three crops used for biofuels.
- 7 **List** three foodstuffs that have increased in price because of the increase in corn prices in the United States.

Understanding

- 8 **Explain** why restrictions were placed on the size of sharks caught for food.
- 9 **Explain** why mercury and lead are dangerous to humans.
- 10 Copy and complete the following table to **describe** the effects of the listed bioaccumulated toxins.

Toxin	Effects on humans and other species

- 11 **Describe** what causes blue-green algae to bloom.

- 12 **Explain** why some farmers are:
 - a excited at growing genetically modified crops
 - b worried about the introduction of genetically modified crops into their area

- 13 Is bioaccumulation a problem for vegetarians? **Explain** why or why not.

Applying

- 14 **Identify** who will be most affected by the increase in prices of basic foodstuffs due to their use in biofuels.

Evaluating

- 15 **Propose** reasons why genetically modified food is labelled as such.
- 16 Little is known about dioxin poisoning. **Propose** reasons why dioxin and not 'regular' poisons like strychnine (rat poison) or arsenic was chosen by Yushchenko's alleged assassins.
- 17 Would you feel comfortable eating food from genetically modified crops? **Justify** your answer.
- 18 Many people around the world do not want to eat food that has been genetically modified or that contains GM ingredients. **Propose** some economical advantages of Australia being GM-free.

Creating

- 19 **Construct** a carefully considered argument for or against any of the ideas presented in this unit.

8.4 INVESTIGATING

Investigate your available resources (for example, textbooks, encyclopaedias, internet) to find out the mercury bioaccumulation that occurred in Minamata and Niigata (Japan) and/or Basra (Iraq). From your research, find:

- when it happened and the sources of mercury
- what the symptoms were for those affected
- what the long-term prognosis was for those affected
- what measures were taken to stop the flow of mercury into the food chain.

8.4 PRACTICAL ACTIVITY

1 Bioaccumulation

Aim

To role-play bioaccumulation

Equipment

- 1 counter
- marble
- Lego block or some other object per student
- a defined and cleared area where students can run and not get hurt if they fall (e.g. on grass or carpet)

Method

- 1 Each student starts with a single counter, marble or Lego block representing a single 'dose' of a toxin.
- 2 Students are to play 'touch-chasey', trying to touch as many people as they can. Any student who is touched exits the game after passing over their counter(s) to the person who touched them.
- 3 The game continues until only a few students remain.
- 4 Record the number of counters each 'survivor' has at the end of the game.

Questions

- 1 **List** the toxins that the counter could represent.
- 2 **Describe** how the food chain is represented in this game.
- 3 **Describe** how people were 'eaten' in the game.
- 4 **Explain** how the role-play modelled bioaccumulation.

context

Life is increasingly being influenced by new technologies. The use of stem cells to treat disease and cloning are two

biotechnologies that can affect human lives very directly. These technologies raise significant social and ethical issues.

Stem cells

We all started as a single cell, called a **zygote**, formed when a single sperm cell fertilised a single egg cell. The zygote cell soon divided to become two identical daughter cells. These then divided again to become four cells, then eight, then 16 and so on. At this stage, all the cells are identical and are known as **embryonic stem cells**. About three weeks into pregnancy, the stem cells start to change.

They start differentiating into all the different and specialised cells that are found in the human body. Some will become muscle cells, some will become brain cells, while others will become skin cells and fat cells. By the time a baby is born, almost every cell in the body has formed the structure required to carry out its specific job—for example, carrying oxygen (red blood cells),

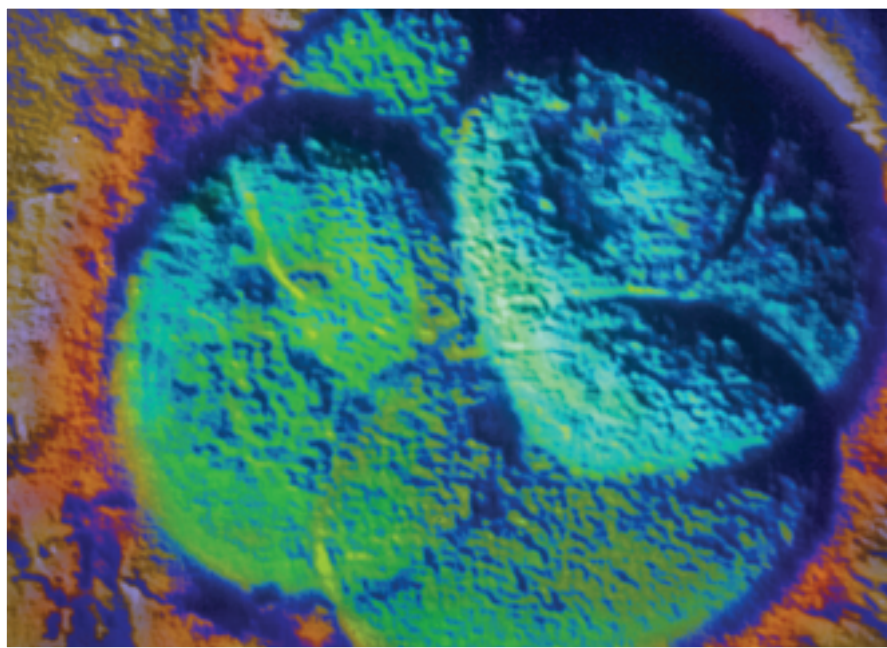

Fig 8.5.1 Technology is beginning to cross the boundary into our bodies, changing human beings and how they are made.

rhythmic pulses (heart muscle cells) or transmitting electrical impulses (nerve cells).

Once born, humans have some stem cells, but not many. These **adult stem cells** can form into new skin, muscle or bone cells which allows repair of relatively minor injuries such as bruises, cuts and broken bones. These stem cells, however, are incapable of forming into new nerve cells. This means that once born, humans cannot repair injuries to the nervous system. This is most evident in injuries to the brain or the spinal cord. Brain injuries, stroke and spinal cord injury cannot be repaired because there are no stem cells to form into new nerves. Likewise, degenerative conditions of the brain like Parkinson's disease and degenerative nervous conditions like multiple sclerosis (MS) cannot be halted. They cannot be reversed and their scarring cannot be repaired.

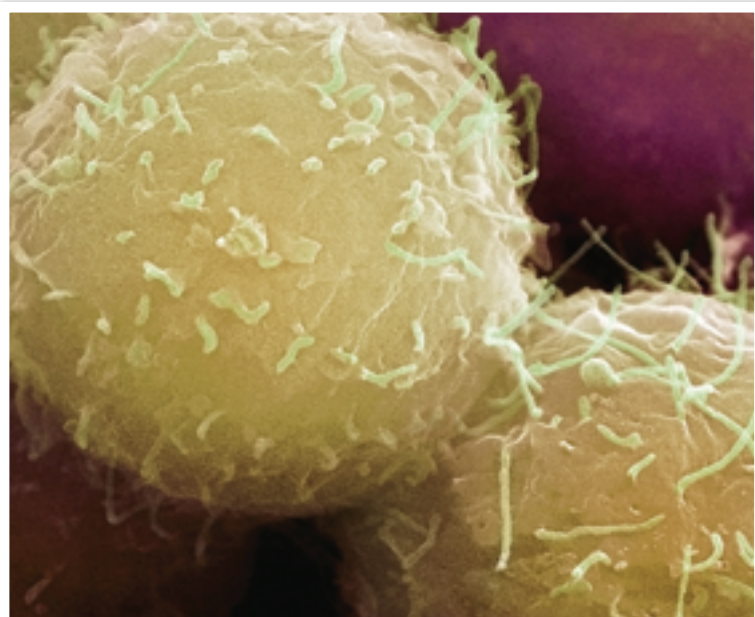

Fig 8.5.2 Embryonic stem cells have the ability to change into every other different cell in the body.

Stem cell research

Embryonic stem cells

Embryonic stem cells have a unique ability to change into any cell of the human body. Researchers are investigating ways of using them to repair serious damage.



Figure 8.5.3 The stem cells in this eight-week-old foetus are clearly starting to differentiate into brain cells, blood cells, retina cells and skin cells.

Stem cells are removed from an immature form of an embryo (called a **blastocyst**) and are then cultivated to form the body cells required.

These might be skin cells for serious burns victims, brain cells to repair damage from stroke or traumas like car accidents, or nerve cells to repair the spinal cord.

Embryonic stem cells offer the hope of repairing damage that can destroy the life of those affected by accident or disease. This research gives hope to:

- paraplegics and quadriplegics (more properly known as tetraplegics), giving them the possibility of walking again
- those who have had a serious stroke, allowing them to recover lost brain function
- those who have had heart attacks
- those with serious burns, stopping dehydration and infection and allowing them to recover
- those who have MS or Parkinson's disease.

Science Clip

No more jabs

In February 2008, scientists in California were able to make human embryonic stem cells grow into pancreas cells, working with the cells implanted in mice. Diabetes occurs when the pancreas does not produce insulin properly, and if new pancreas cells could be grown from stem cells some forms of diabetes could be cured rather than simply treated with daily insulin injections.

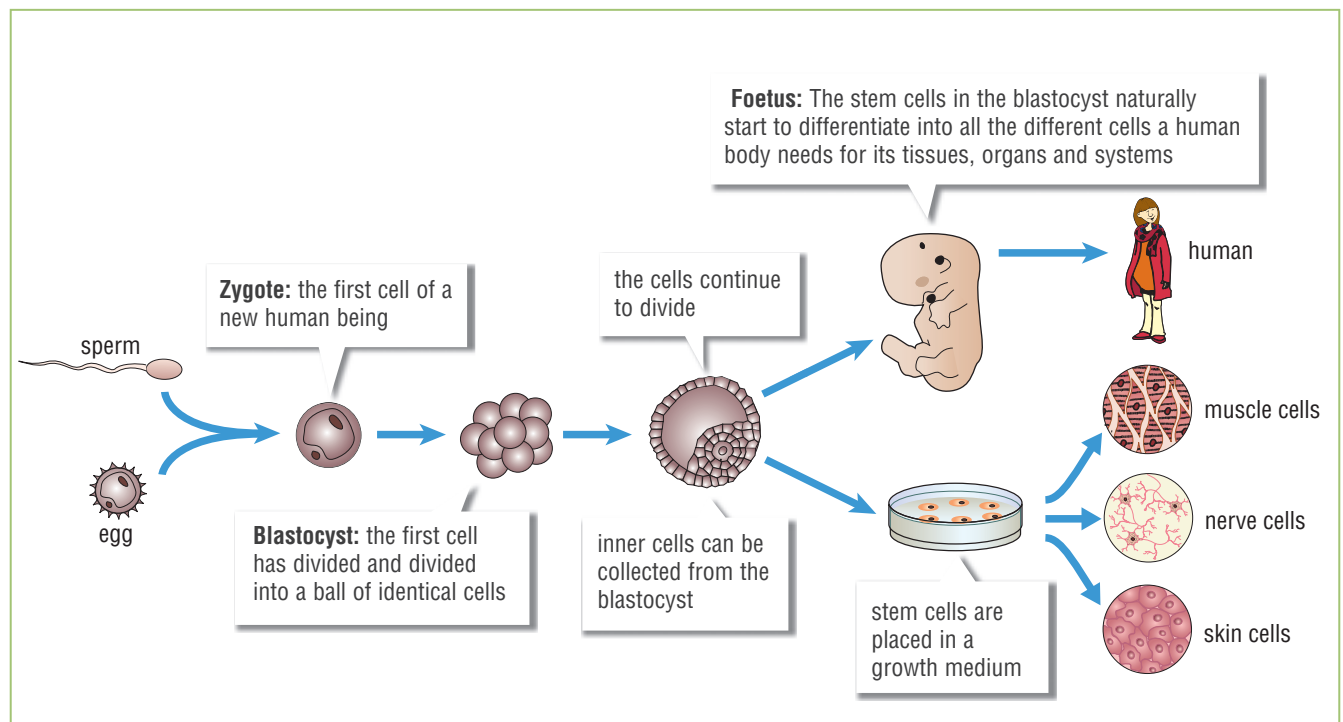

Fig 8.5.4 Stem cells in the blastocyst will develop into all the cells required to make up a new human. The blastocyst can also be 'harvested' to remove the stem cells for therapeutic use.

Is it right?

The process of harvesting embryonic stem cells destroys the six- to eight-day-old embryo.

This obviously brings a moral dimension to the issue of embryonic stem cell research.

Many believe it is morally wrong to destroy any human life, regardless of its age and level of formation, whether it can survive on its own, or when analysing the benefits that might arise from using its cells.

A further moral issue is how and why these embryos are created in the first place. Multiple eggs are generally fertilised in procedures such as **in-vitro fertilisation (IVF)**. IVF involves using sperm to fertilise human ova in the laboratory for later implantation in the uterus. While some of these will be implanted in the donor female, the rest will be frozen for possible future implantation. Will these 'leftover' frozen embryos be made available for stem cell use or will embryos be formed specifically for use in the program?

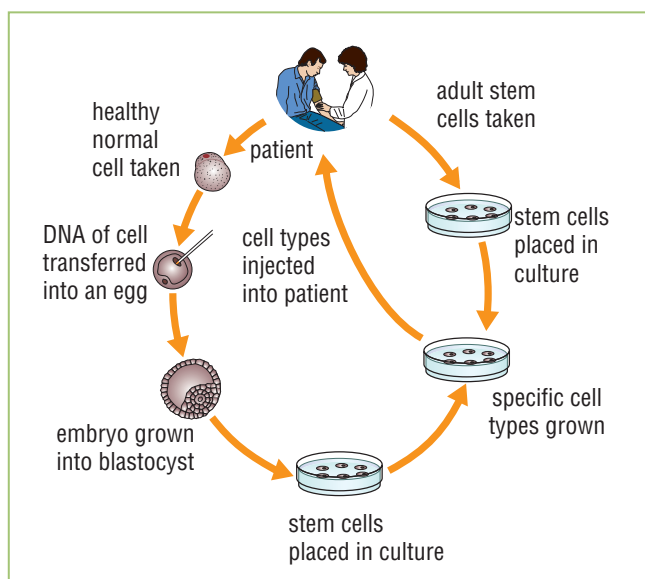

Fig 8.5.5 How stem cells could be used

Adult stem cells

Although adults have some stem cells, the body cannot normally use them to repair the nervous system. In recent years, however, there has been some research success in turning these cells into the cells required to repair the damage.

The advantage of using adult stem cells is that the process does not need an embryo to be formed or destroyed. The moral issue of destroying potential human life is removed from the debate.

To date, adult stem cells seem to be less effective.

Transplants and rejection

Transplants of any material into the human body usually lead to rejection. Human-to-human transplants (referred to as **allografts**) such as hearts, kidney or corneas, are commonly rejected by the recipient's body because they do not match the exact DNA makeup of the donor organ. The recipient's body sees the transplanted organ or part as foreign and will begin to attack it. The chance of rejection is minimised by taking heavy and regular doses of anti-rejection drugs. Unfortunately, these drugs also lower the immune system, making the recipient much more vulnerable to disease and infection.

Transplants are less likely to be rejected if the donor and recipient are closely related as the DNA in the donor organ's cells is close in structure and composition to that of the recipient. It is minimised even further if the donor and recipient are identical twins, with identical DNA.

Although stem cells may come from an unrelated donor, they have their DNA replaced with that of the person who will eventually receive them. Rejection is therefore very unlikely.

Science Clip

Xeno and other transplants

Artificial transplants (such as artificial heart valves and replacement hips) need to be made from inert materials such as stainless steel, titanium or silicone to minimise rejection. Animal-to-human transplants (referred to as **xenotransplants**) can be successful, especially if the donor is a pig. Pigs have similar DNA to humans and so humans do not reject them as much as organs from other animals. Once again, anti-rejection drugs must be taken. In the near future, it is hoped that genetic modification will even allow 'human' organs matched to a particular recipient to be grown in pigs.



Fig 8.5.6 Identical twins have identical DNA and will not reject tissue or organs transplanted from one body to another.

Cloning

Humans and all other complex animals undergo sexual reproduction. Half the genes in a new individual come from its father and the other half come from its mother. Each person has some characteristics inherited from each parent, although these might not always be obvious due to the interaction of dominant and recessive genes.

Go to  Science Focus 4 Unit 3.4

Cloning is a procedure in which an egg cell has its nucleus replaced with a full set of genes from one parent. This means that the new individual will be a perfect genetic copy of its parent. The eventual adult form of the clone may not, however, be identical to its parent as the environment in which it grows often decides how particular genes are expressed. Although genetically identical, it may be a little different to its parent.

Animal cloning

The first animal ever cloned using a cell from an adult animal was Dolly the sheep. Born in 1996, she died in 2003 after successfully producing six lambs (a single lamb, twins and triplets). Although sheep of her breed usually live 12 to 15 years, Dolly only lived to the age of six. Some speculated that Dolly's mother was six when the cell used to clone Dolly was taken and that her cells were 'already aged'. The scientists who cloned Dolly disagreed. Dolly died of lung cancer—other sheep in her flock also died from this disease.

Since Dolly, about 20 different animal species have been successfully cloned.

Human cloning

Humans have been successfully cloned, but the embryos created were only allowed to develop to a few cells and were then destroyed. Although a controversial practice, cloning has also been used to create embryos for the harvesting of stem cells. There have been no documented cases of the birth of a cloned human but there have been



Fig 8.5.8 Cloned humans would be genetically identical.

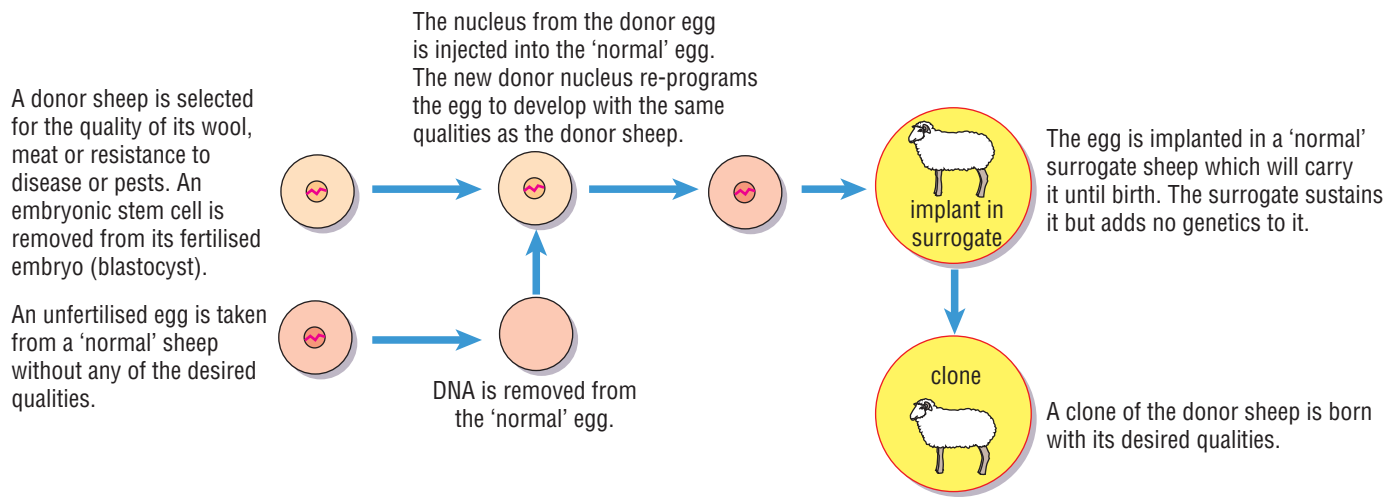

Fig 8.5.7 The process of cloning

a number of explosive claims in the media that it has already happened. Given the fact that all the technology is readily available, it seems possible that it may have happened in secret, or might happen soon.

Many people believe it would be unethical to create a human clone. There is a non-binding United Nations

convention, adopted in 2005, that bans human cloning for reproductive purposes. Australian laws also ban cloning for this reason, although a law passed in 2006 allows cloning to create embryos for stem cell research.



8.5 QUESTIONS

Remembering

- State** what type of cells these can turn into:
 - embryonic stem cells
 - adult stem cells
- State** the stage of development at which embryonic stem cells are removed.
- List** the advantages and disadvantages of using these cells for therapeutic use:
 - embryonic stem cells
 - adult stem cells
- Regarding Dolly, **state**:
 - what type of animal she was
 - the year in which she was born
 - the age at which she died
 - why she died
 - how many young she gave birth to

Understanding

- Once damage has been done to the central nervous system it can never be repaired.
 - Explain** why.
 - Describe** the diseases and conditions that are incurable because of this fact.

- Organs and tissue can be donated between identical twins with little chance of rejection. **Explain** why.
- Recipients of 'normal' transplants need drugs for the rest of their lives. **Explain** why.
- Explain** why stem cells are not rejected by their recipient.
- A clone is not always identical to its parent. **Explain** why.

Evaluating

- Are identical twins clones? **Justify** your answer.
 - Analyse** each of the following scenarios by:
 - listing the points for or against the proposal
 - deciding what you would do in each case
 - justifying your decision in each case
 - Would you clone your pet?
 - You have an incurable condition that could be repaired with embryonic stem cells. Would you have the procedure?
 - A laboratory wants to clone all the important scientists of the past so that their skills can be used to solve problems in the modern world. Will you fund its work?
 - A laboratory wants to clone humans to create organs for transplant. Will you fund its work?

Creating

- Construct** a carefully considered argument for or against any of the ideas presented in this unit.

8.5 INVESTIGATING

Investigate your available resources (for example, textbooks, encyclopaedias, internet) to complete the following tasks.

- Find out what the law is in New South Wales and other states about cloning and embryonic stem cell research.
- Research face transplants. Find out:
 - how many partial and full face transplants have occurred
 - why the transplants were carried out
 - what the life of the recipients was like before the transplant and after it
 - complications due to the operation
 - whether the recipient looks like the face donor, their old self or something in-between

CHAPTER REVIEW

Remembering

- 1 List** the three main greenhouse gases.
- 2 Name** the subatomic particles emitted during fission that cause a chain reaction.
- 3 Recall** the bioaccumulation of toxins by matching the toxin with the word/s that best identifies it—the words are Pb, pesticide, 'mad as a hatter', Victor Yushchenko:
 - a** mercury
 - b** lead
 - c** DDT
 - d** dioxins
- 4 Name** the GM crop that is currently being grown in Australia:
 - a** to be processed into cooking oils
 - b** to be woven into fabric
- 5 List** two reasons for growing GM food crops and two against.
- 6 Name** two degenerative conditions of the central nervous system.
- 7 List** reasons why people select different restaurants at which to eat.

Understanding

- 8 Explain** why uranium ore in the ground does not explode.
- 9** One method of disposing of nuclear waste in the past was to dump it in the ocean in sealed drums. **Explain** why this is not good practice.

- 10 Explain** how sharks can have dangerously high levels of mercury.
- 11 Explain** what blue-green algae are, why they are dangerous and what encourages their growth.
- 12 Explain** why many people object to the therapeutic use of embryonic stem cells.
- 13** Most scientists believe that embryonic stem cells hold more hope in therapeutic use than adult stem cells. **Explain** why.

Applying

- 14** Australia releases about 320 million tonnes of carbon into the atmosphere each year by burning fossil fuels. Given that our population is approximately 18.5 million people, estimate Australia's carbon emission per person. **N**

Analysing

- 15 Contrast** nuclear fission with nuclear fusion.

Evaluating

- 16 Propose** why fusion reactors are currently not economical.
- 17** Are biofuels a good thing? **Propose** why or why not.
- 18** Have humans been cloned? **Justify** your answer.
- 19 Propose** action on three issues in this chapter that you believe are the most pressing and important to you.

 **Worksheet 8.6** Crossword

 **Worksheet 8.7** Sci-words



Individual research project

9

Prescribed focus area

The nature and practice of science

Key outcomes

5.2, 5.13, 5.14, 5.18, 5.22.1

- Scientific processes test whether ideas are valid or not.
- A question can lead to the development of a hypothesis that can be tested or researched.
- Data needs to be recorded along with appropriate units.
- When planning experiments, dependent, independent and controlled variables need to be specified.
- A logical procedure needs to be developed that only changes one independent variable at a time.
- A number of trials increases the accuracy of any measurements taken.
- Information can be gathered from a range of secondary sources.
- Information can be drawn from graphs of different types, other texts, AV resources, CD-ROMS and the internet.
- The reliability of data and information should be compared with that obtained from other sources.
- Trends, patterns, relationships and contradictions can be sought from data and information.
- Inferences can be justified in relation to gathered information.

context

Everyone is good at something: each one of us has certain skills at which we excel. When we work as a group, the different skills of each group member can be used. When you work as an individual, however, you must manage and complete the task by yourself. Individual research can be very demanding, but very

rewarding. You need to be able to take an idea, put it into practice and see it through to completion. Working by yourself does not mean you are alone. Finding people to support you and offer advice is one skill that may get you through when you can't think what to do next.



Fig 9.1.1 Sometimes it's necessary to complete a task by yourself. This requires organisation and self-discipline.

**Independent work skills**

Performing and assessing a science investigation is like any other task you undertake in life. Decisions need to be made, aims need to be set out and good organisation with an outline on how you will perform it is required. This project will allow you to apply and develop important skills and some of those are:

- setting suitable timelines
- designing, conducting and evaluating an investigation
- identifying problems and applying creative solutions to them
- working safely with a variety of equipment in different environments
- developing and applying scientific thinking and problem-solving techniques
- finding someone to support you in difficult times
- presenting data and information in appropriate forms
- communicating information, and your understanding of it, to your peers.

Surviving on your own

As an individual you will be good at some of the skills outlined above, and probably not so good at others. Each person is different and has their own strengths and weaknesses. This makes everyone unique in their own way. When working by yourself you have to build on your strengths and find ways of dealing with your weaknesses. As you complete your project, try to identify the characteristics that you already have and which ones need improving.



Creativity

A creative person will come up with new ideas, see relationships between results and information, and invent new ways of doing things. They will often solve problems in unusual ways.

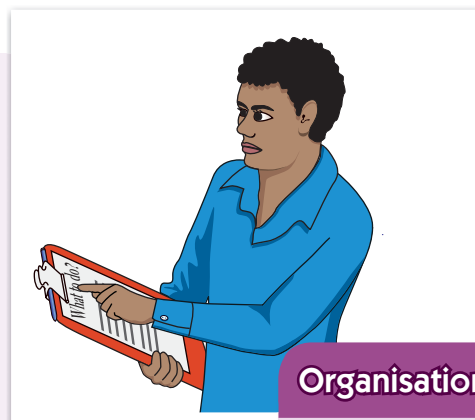

Organisation

An organised person will plan timelines and resources carefully. They might make lists, find out what they need, and collect resources before they start working. They will often proceed in an organised manner, like the method you use when performing an experiment.

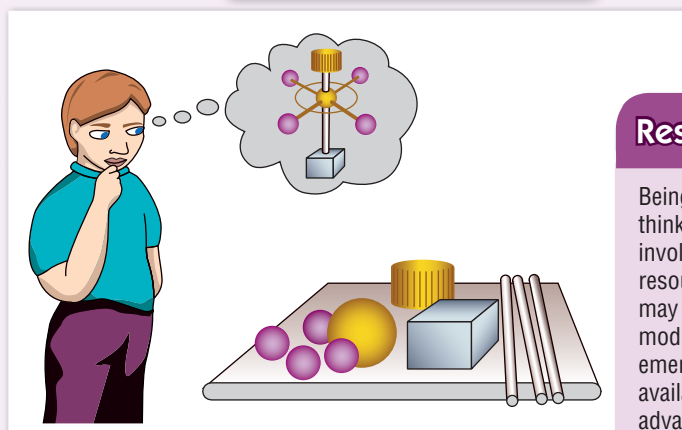

Resourcefulness

Being resourceful involves thinking 'outside the square'. It involves making the most of the resources you have available. It may also include changing or modifying the plan as new ideas emerge, or making use of the available resources and taking advantage of any opportunities that arise.

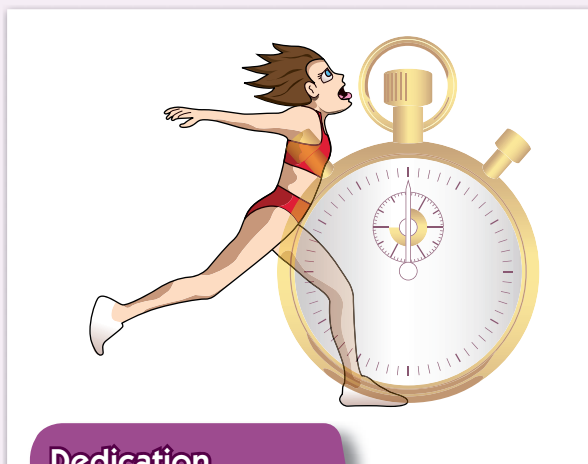

Dedication

Dedicated people want to achieve and succeed. They are able to meet goals and see a project through to completion.



Self-motivation

Self-motivated people know why they want to do something. Make sure the investigation you choose is interesting and challenging, as this is likely to keep you motivated.

Fig 9.1.2 Individual work skills

Career Profile

Science teacher

Science teachers in secondary schools teach science to Year 7 to 10 students. In Years 11 and 12 they specialise in teaching physics, chemistry, biology, earth and environmental science or senior science. They will have studied specific subjects at university as well as undertaken special studies in education.

Science teachers are involved in:

- preparing daily lessons and long-term teaching programs
- teaching, using different techniques such as classroom activities, discussions, experiments, projects, assignments and excursions
- taking into account and catering for the different needs of students
- using information technology to assist in lesson preparation, delivery and reporting
- setting assessment tasks, projects, assignments and homework, marking and collating the results
- evaluating and reporting on the progress of students, and discussing individual performance with students and parents
- participating in the wider school community through activities such as sports, camps, student support groups and extra-curricular activities.

A good science teacher will be able to:

- plan and organise various activities on a daily basis
- show enthusiasm for learning and a love of science



Fig 9.1.3 A science teacher uses a model to demonstrate the night sky.

- communicate concepts and instructions clearly
- enjoy working with young people and other teachers
- relate well to and communicate with people of all ages and backgrounds
- be patient in dealing with people
- work as a member of a team
- keep accurate records and prepare reports.

Science Clip

Fluffy belly buttons

Dr Karl Kruszelnicki carried out the world's first belly-button lint (BBL) survey. Some variables included in the survey were the degree of overall body hair, 'innie' or 'outie' belly buttons, skin type and whether you have a navel ring. The study collected information about whether the colour of your belly-button lint is related to clothing colour and whether clothes were washed in a top-loader or front-loader. The results showed that you are more likely to have BBL if you're male, older, hairy, and have an 'innie'. This important research won Dr Karl an Ig Nobel Prize for Popular Science.

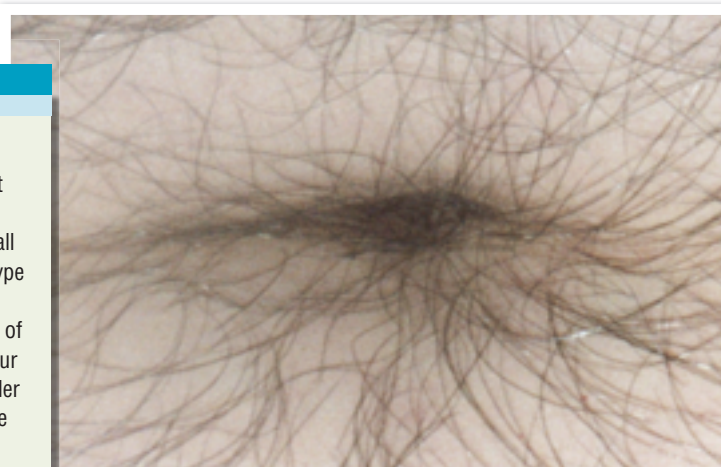

Fig 9.1.4 The winner: older, hairy males with an innie have the most belly-button lint.

9.1 QUESTIONS

Remembering

- 1 **List** four skills that you are good at.
- 2 **List** five skills in order from what you consider to be most important, down to the least important.

Applying

- 3 Using the table below, match the characteristic with the correct description.
- 4 **Identify** two of your individual strengths. **Explain** why you chose each. (You can use the list below as a guide.)

Characteristic	Description
Resourcefulness	Makes lists and collects resources before starting work and then proceeds in a series of steps
Self-motivation	Meets goals and sees a project through to completion
Creativity	Makes the most of the available resources and takes advantage of opportunities
Organisation	Knows the reason for wanting to do something and makes sure work is interesting and challenging
Dedication	Invents new ways of doing things and solves problems in unusual ways

Analysing

- 5 **Compare** the characteristics of creativity and resourcefulness.

Evaluating

- 6 **Evaluate** the importance of having a mentor when working alone.
- 7 **Propose** ways to keep self-motivation high.
- 8 **a** Although part of a team, teachers do a lot of independent work. **State** the key characteristics of a good science teacher.
b **Justify** your choice in each case.
- 9 Imagine you are a solo astronaut orbiting Earth in a space station. Suddenly there is an explosion and cabin oxygen slowly begins to leak into space. What will you do?
a **Identify** the two main skills you will need to solve this problem.
b **Identify** the two main characteristics that you think will be required to get out of this situation alive.
c Is one skill or characteristic more important than others in this situation? **Justify** your answer.

9.1 INVESTIGATING

Investigate information from the internet about an unusual science research project that involves creativity and curiosity, and is funny. Present your information to the class, outlining how the research was done, what was discovered, and how this information is thought to be useful. Remember not to take yourself too seriously.

e-xploring

Find out more about the Ig Nobel Prize by connecting to the **Science Focus 4 Second Edition Student Lounge** and clicking on the web destinations. Watch past presentation ceremonies online, see a list of past winners and their research ideas, and be amused.



Prescribed focus area The nature and practice of science

Science can be weird and funny. To be a good scientist requires not just reasoning and objectivity, but creativity and curiosity, which usually come from people with interesting and even funny personalities!



Fig 9.1.5 Scientists have found that they can stimulate the appetite of leeches with sour cream.

Oldies but goodies

Scientists often engage in some very amusing research. There are subjects you would never have thought of! Some investigations have included:

- the five-second rule (an experiment which tests whether food is safe to be eaten if it falls on the floor for less than five seconds)
- the best way to dunk a biscuit
- how to levitate frogs and a sumo wrestler with an electromagnet
- the effects of ale, garlic and sour cream on the appetites of leeches (sour cream was the biggest appetite stimulant)
- the role of elevator music in preventing the common cold
- the belly-button lint survey conducted by Australian scientist Dr Karl Kruszelnicki
- the invention of software that detects when a cat is walking over your computer keyboard.



Fig 9.1.6 Can frogs really levitate? One scientist proved that they can, with the help of an electromagnet.

All of these investigations have been awarded Ig Nobel Prizes. The Ig Nobel prizes are awarded for science that ‘first makes people laugh, and then makes them think’. The idea of these awards is to celebrate unusual science, to honour the imagination and promote popular science in the wider community. It is said that the Ig Nobel Prizes honour those achievements that cannot and should not be reproduced.

Prizes are awarded at Harvard University in the United States, and the prizes are handed to the Ig Nobel winners by genuine Nobel Prize winners, who are amused at their colleagues’ investigations. Many Ig Nobel winners are serious scientists.

One Ig Nobel prize winner is physicist Dr Len Fisher. Dr Fisher is an Australian (based at Bristol University in England) who has devoted much of his time to understanding the science behind everyday life. He combines scientific reasoning and method with an enthusiasm for the bizarre. Dr Fisher’s Ig Nobel prize was awarded for his research into dunking biscuits.

The physics of dunking biscuits

Dr Fisher and his research team showed that a dunked biscuit releases up to 10 times more flavour than a dry biscuit. A biscuit is basically lumps of starch glued

together with sugar. When dunked, the hot tea or coffee enters the pores in the surface of the biscuit and is absorbed by the starch grains that swell. The sugar also begins to melt, giving a biscuit that is purely starch but much softer than the original biscuit, which in turn makes it unstable.

Eventually the team used an old formula devised in 1921 that describes the dunking process. This is how it works: the perfect dunking time is equal to the height (L) the liquid rises up the biscuit squared, multiplied by four times the viscosity (η density of liquid) divided by the surface tension (γ) of the tea, multiplied by the average pore diameter (D), or:

$$t = \frac{L^2 4\eta}{\gamma D}$$

The research is yet to be completed as Dr Fisher believes that the temperature of the tea also has an impact on dunking times.

This research was sponsored by a biscuit company. The best dunking time for a gingernut biscuit was three seconds, and eight seconds for a digestive biscuit. Soon a more user-friendly version of information about dunking will be available that gives the best time for dunking for different types of biscuits. If you want to get the most out of your biscuits, keep an eye out for it!



Fig 9.1.7 The optimum dunking time for gingernut biscuits is three seconds.

The perfect cheese sandwich

The perfect cheese sandwich is another of Dr Fisher's great discoveries. This work was sponsored by the British Cheese Board. Being a physicist, Dr Fisher could not help but develop an equation to describe this phenomenon:

$$\% \text{ cheesiness} = \left(\frac{100}{2.8} \right) \times \text{thickness of cheese (mm)}$$

This equation is specific to cheddar cheese, and the value 2.8 changes with different types of cheese. This formula was derived using a series of experiments that involved inserting a tube up the nose to measure the concentration of aromas produced while chewing and swallowing a cheese sandwich.



Fig 9.1.8 The cheesiness of a sandwich was tested using an aroma-detection device.

This formula shows that the perfect cheese sandwich requires a slice of cheddar cheese 2.8 mm thick to gain maximum percentage cheesiness. Thinner slices had lower percentage cheesiness and were not as tasty. Try working it out yourself with the formula!

After a certain thickness, no amount of extra cheese will add to the cheesy aroma impact of the sandwich. Dr Fisher also discovered that adding butter or margarine enhances cheesiness, probably because the fat in butter and margarine dissolves the flavours, and the fat then coats the mouth and tongue and holds the flavours in the mouth longer.

What is the impact of this research? It is thought that more research should be undertaken that will allow us to better understand the design of healthy and tasty foods, in order to produce maximum flavour release.

Wasted gravy

Want more? Another bizarre example of Dr Fisher's work comes from British people wasting 681 912 litres of gravy a week. This is gravy poured onto plates and then not consumed.

To solve this problem the gravy absorbency index was developed where:

W = weight of uncooked food

D = weight of cooked food

S = shrinkage factor

$$\% \text{ gravy uptake} = \frac{\left(W - \left(\frac{D}{S}\right)\right)}{D \times 100}$$

Scientific method was used to measure the weight of gravy absorbed according to time at different gravy temperatures.

Research findings

- Absorption times can be accelerated by 20 per cent if gravy is very hot.
- A food's ability to mop up gravy is also dependent on the time it is in contact with the gravy, and the density of the food.
- For efficient gravy absorption, food should be eaten in the correct order.
 - Start with meat as it absorbs no gravy.
 - Green vegetables should be eaten next as they absorb up to 15 per cent of their dry weight within 30 seconds.
 - Roast potatoes should be eaten last as they

absorb up to 30 per cent of their dry weight, and take as long as five to 10 minutes to absorb this amount.

- Ciabatta, an airy Italian bread, is better than ordinary bread at soaking up leftover gravy, absorbing 120 per cent of its dry weight.
- Dr Fisher even has a suggestion for using popcorn. Popcorn has an 'off the scale' gravy absorption rate of 600 per cent plus. Fisher added, 'You just have to move fast before it goes all soggy'.

The study showed that there is a scientific reason for gravy wastage. People eat their food in the wrong order!

Science Clip

Nuts for physics

A bowl of mixed nuts may be good Christmas food, but for physicist Paul Quinn it's a nutty physics project. Quinn was puzzled by an odd nut-bowl phenomenon. Brazil nuts always seem to sit on the top of smaller nuts. But shouldn't gravity pull the heavy nuts to the bottom of the bowl, while lighter nuts rest on top? Quinn calls the phenomenon the Brazil-nut problem, or BNP.

Quinn found that a nut 'sinks or swims' depending on the ratio of two properties: mass and diameter. If a fat nut is twice the mass and diameter of the other nuts in the bowl, it surfaces. But if the nut is six times the mass and only twice the diameter of smaller nuts, it sinks.

STUDENT ACTIVITIES

- 1 a Use the formula for the perfect cheese sandwich to complete the following table. **N**

Thickness of cheddar cheese (mm)	Calculation	% Cheesiness
2.8	$\% = \left(\frac{100}{2.8}\right) \times 2.8$	100
2.5		
2.0		
1.5		
1.0		
0.5		
0.0		

- b Gouda cheese was discovered to have a percentage cheesiness of 100 per cent at a thickness of 3.1 mm. **Calculate** the percentage cheesiness of a sandwich containing a slice of gouda that is 2.3 mm thick.

context

Investigations are an important part of science and the life of a research scientist. This is why investigations need to be both creative and motivating for the scientist to be interested in completing them. Selecting an interesting investigation will make your research more successful. It may

be something that interests you during science classes or at home, or it may even relate to your favourite hobby, sport or pastime. Be creative and investigate something unusual!

Types of investigation

Selecting an investigation is a very important part of your project. The investigation should allow you to apply the skills that you have learnt in science. When choosing your investigation make sure:

- you are interested in learning about your chosen topic
- it is challenging enough to keep you motivated
- it is not too hard to complete
- it is safe and does not pose a danger to people or the environment
- you can get the required equipment and materials
- it can be finished in the agreed time
- it is open-ended, meaning there are many possible solutions and it cannot be answered with simple answers such as true/false or yes/no.

There are three main types of investigation that you may undertake for your individual project. Each type is explained in this unit, with examples to help you in selecting a topic.



Fig 9.2.1 This student is performing a first-hand investigation in chemistry to find out the acidic content of different lemonades.

Science Clip**Great farts!**

Performing an investigation can be fun! As well as completing belly-button lint research, Dr Karl also completed the Great Fart Survey. This unusual scientific research showed that Aussie kids fart 24 times a day. It also revealed that although boys like to talk a lot more about their farts than girls, there was no difference between the amount and types of farts that boys and girls do.

Science Clip**The five-second rule**

High-school student Jillian Clarke investigated the scientific validity of the 'five-second rule'. If food falls to the floor and it's in contact with the floor for fewer than five seconds, it's safe to pick it up and eat. She found that 70 per cent of women and 56 per cent of men are familiar with the rule, and most use it to make decisions about tasty treats that slip through their fingers.

The rule dates back to the time of Genghis Khan, who first determined how long it was safe for food to remain on a floor when dropped. Khan had slightly lower standards—he specified 12 hours!

First-hand investigation

A first-hand investigation can be an experiment or series of experiments to investigate a topic of your choice. By completing this type of investigation you will show your skill at planning, conducting and reporting on an area of science. You will need to design a fair test that will give accurate and clear results.

Some experiments could investigate questions like these.

- Does heart rate increase with music type or increasing volume?
- Who is generally fitter—males or females? Who has the lowest average heart rate, and how long does heart rate take to return to normal after exercise?
- Which type of sausage contains the most fat?
- Which home insulation works best?
- What factors affect the growth of bread mould?

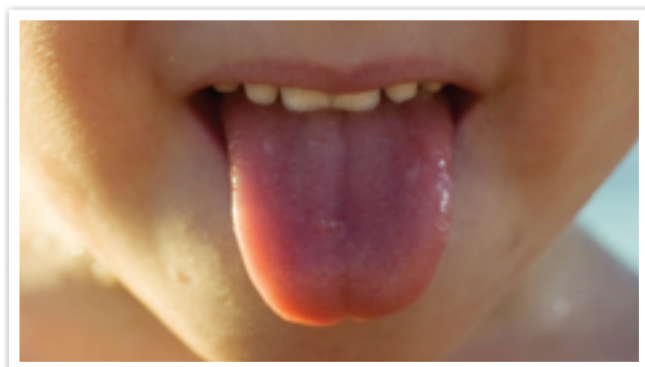

Fig 9.2.2 Your investigation needs to be open-ended no matter what it might look at.

- Which type of sunglass lens blocks the most light?
- What percentage of lawn seed in a package will germinate?
- How much water is in different fruits?
- Does the human tongue have definite areas for certain tastes?
- How does light direction affect plant growth?
- What is the best insulation for making an insulated coffee mug?
- How does the colour of a material affect its absorption of heat?
- Which soft drink has the most bubbles or dissolved gas?

Demonstration of a scientific principle

To complete these types of investigations, you will need to demonstrate your understanding of one or more basic principles of science. You will have to interpret these principles and then design and conduct an experiment or series of experiments to prove them correct.

Many of the investigations you choose will involve some of the following scientific principles:

- conservation of matter in chemical reactions
- conservation of energy



Fig 9.2.3 A student demonstrating the scientific principle of photosynthesis by measuring oxygen produced by a plant

- simple inheritance of a characteristic—dominant and recessive
- sound travels by waves
- Newton's Laws of Motion
- Brownian motion
- Ohm's law
- chemical and physical change
- photosynthesis and respiration
- diffusion
- refraction, reflection and dispersion

Construction of a model

By completing this investigation you will show your skill at building a model and manipulating materials in order to demonstrate a scientific principle or investigate an aspect of science of your choice. You will have to plan, design and construct your model. This will involve understanding the scientific principles behind your model in order to make it informative and accurate.

Some examples

Build a model to demonstrate or investigate any of the following:

- the greenhouse effect
- collisions: airbags or crumple zones
- generation of electricity-wind power
- a solar car or device
- an electrical device
- a speaker
- part of the body such as the ear or heart
- atoms: solids, liquids and gases
- atoms: molecules and chemical reactions
- Ohm's law
- Newton's Laws of Motion
- the operation of a remote-sensing satellite
- different types of earthquake waves
- an optical device such as a microscope, telescope, projector or binoculars, showing how it works
- the best direction for a house to face—how do we keep sunlight out in summer, and let sunlight in during winter?
- how a lung works—how does the movement of the diaphragm relate to the volume of air inhaled?
- how the current and voltage in a circuit affect the power of an electromagnet
- the perfect beach—how the depth of water affects the height of waves

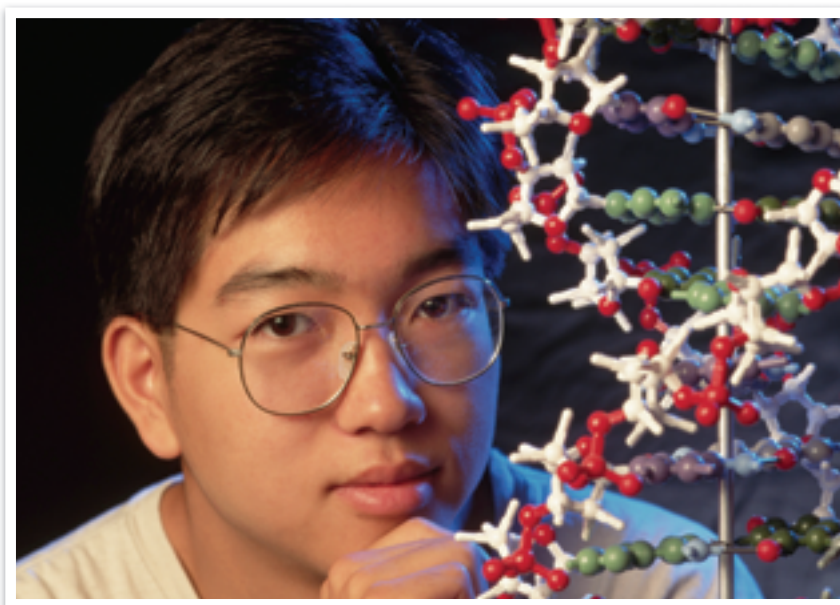

Fig 9.2.4 This student used a model to demonstrate the structure of DNA.

- the amount of tar in cigarettes—you may need teacher and parent permission to complete this investigation
- how the mass of an object affects stopping distance
- how lifting an object is made easier by ramps or pulleys
- reproduction rates in bacteria using computer modelling
- the aerodynamic shape of different car designs using a wind tunnel.

Note: there are many other investigations that you could do, but you will need to negotiate with your teacher if you select a different problem. Further ideas can be found by searching the internet.

Science Clip

Murphy's Law and others

You will have heard of Murphy's Law: 'Anything that can go wrong will go wrong'. There are other similar 'rules' that you may encounter throughout your project, so be prepared.

- Nothing is as easy as it looks.
- Everything takes longer than you think.
- Always keep a record of data—it indicates that you've been working.
- In case of doubt, make it sound convincing.
- Experiments should be reproducible—they should all fail in the same way.
- When you don't know what you are doing, do it neatly.
- If it is green or it wiggles, it's Biology. If it stinks, it's Chemistry. If it doesn't work, it's Physics.

Prescribed focus area The nature and practice of science

You will be required to produce a report based on your work and findings, whichever type of investigation and topic you choose. The following is the basis of the scientific method you need to help you in **designing**, **conducting** and **reporting** your investigation.

Aim

The **aim** outlines the idea or scientific question you are trying to test.

Hypothesis

A **hypothesis** is a prediction or 'educated guess' about what you might find in an experiment. A hypothesis is something that can be tested in measurable terms.

Variables

Identify all the variables that may affect your results. Remember that variables can be classified into three groups:

- **independent variable**—the variable that is changed
- **dependent variable**—the variable that is being measured
- **controlled variables**—the variables that are kept the same throughout the experiment.

Equipment

List all the equipment and materials that you need.

Method

The **method** is a step-by-step set of instructions that other scientists at your level of experience could follow to accurately repeat your experiment.

When writing the instructions, include the following information:

- the one variable that you are going to change
- how you are going to change it and by how much
- how you are going to control all the other variables
- how you are going to measure the changes
- how you are going to record the changes, such as in a results table, diagrams, drawings or photographs.

Your experimental method should be **replicated** a number of times so that a more accurate conclusion can be drawn. This makes your investigation 'reliable'.

Results

Results can be of two types.

- Results or data that are numerical are called **quantitative** as they usually measure amounts or quantities.
- If you are using your senses to observe, you are making **observations**. **Qualitative** observations are written down as a description or recorded as a picture or diagram.

You should also record any other things you notice, particularly any problems you may have had with your investigation. If appropriate, include a photographic essay of your project steps or results. These will assist in your final analysis.

You may be asked to keep a detailed process diary ('Log book') of observations, data, and results while completing your experiment.

Discussion

In the discussion you should **analyse** and **evaluate** your results in detail.

- Analyse and present your data or observations in different ways to show any patterns or trends. This is where a graph may be useful. Line graphs should be used when both the independent and dependent variables are numerical.
- Explain any trends or patterns in your observations, data and results.
- Explain why the results occurred and what they demonstrated.
- Outline any errors that may have affected your results. Errors are unavoidable, but mistakes are because of clumsiness. Report your errors, not your mistakes.
- Evaluate the success of your investigation, explaining how your experiment could be improved to gain better or more dependable results.
- Describe any difficulties or problems you had in doing the investigation.

Conclusion

A conclusion is simply a summary of the results of your experiment. A good conclusion will:

- answer your aim
- identify whether your experiment proved or disproved your hypothesis. Use any trends you saw in the results as proof

- identify any changes that you would make if you had to repeat this investigation.

Resource list

This is sometimes called a **bibliography** and is a list of all the resources and references you used. You may also wish to make any acknowledgements here.

Communicating

When working independently it is vital to be able to communicate your results and knowledge to others. As well as your written report you may be required to present your findings in another way.

When selecting your topic, consider the type of presentation that would best suit your investigation. As you perform your investigation, collect any information

that will allow you to present your findings in a creative and interesting way.

Presentations could take the form of:

- an oral presentation (use props to assist you)
- a demonstration of a model to the class
- a website
- a PowerPoint presentation
- a poster or visual display
- photographic, video or audio material
- a journal article
- a newspaper article.

Use worksheets 9.1 and 9.2 to help you plan your investigation.



Worksheet 9.1 Proposing my big idea



Worksheet 9.2 Planning my investigation

Career Profile

Science laboratory assistant

Laboratory assistants prepare experimental equipment and chemical solutions and maintain a chemical storage area in accordance with safety requirements. They support science teachers and scientists in their work, ordering stock, disposing of waste and helping them improve experiments. They often help with research, carrying out preliminary experiments. Laboratory assistants can be involved in:

- working with teachers or scientists in planning experiments
- cleaning, maintaining and setting up equipment for use in experiments
- performing calculations to prepare correct chemical solutions
- completing routine experiments to help in an investigation
- checking chemical and equipment supplies and ordering and keeping records of stock
- checking that all equipment and chemicals are stored safely
- disposing of waste in a safe manner.

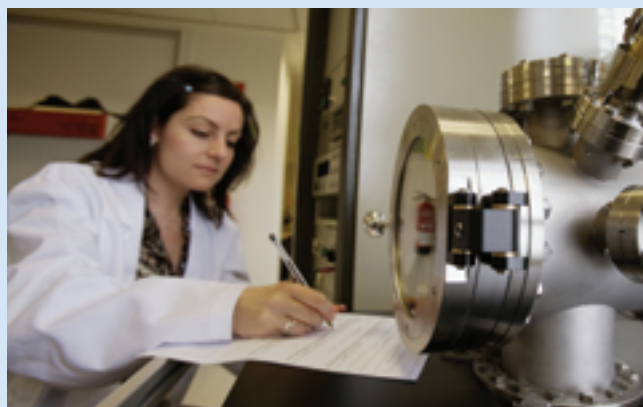

Fig 9.2.5 A laboratory assistant is vital in schools, universities and in research laboratories.

A good laboratory assistant will:

- enjoy scientific activities
- work as part of a team
- solve problems in creative ways
- keep accurate and detailed reports
- follow detailed experimental instructions.

9.2 QUESTIONS

Remembering

- 1 **List** the three types of investigation that may be undertaken.
- 2 **List** the sections of a scientific report.
- 3 **List** three ways in which you could present the results of an investigation.

Understanding

- 4 **Describe** three things you need to consider when selecting a topic for investigation.
- 5 **Define** the term 'controlled variable'.
- 6 **Clarify** the purpose of a conclusion.
- 7 **Explain** why you should only change one variable at a time in any experiment.
- 8 Everyone has different learning styles. **Explain** why it is important to use different techniques when communicating information.
- 9 **Describe** two props that could be used in an oral presentation to help you pass information in a visual form to your audience.
- 10 **Explain** why an experiment should be able to be replicated.

Applying

- 11 **Identify** two ways in which you could communicate the findings of your investigation.

Analysing

- 12 **Distinguish** between:
 - a building a model to **demonstrate** a scientific principle, and building a model to **investigate** an aspect of science
 - b a dependent variable and an independent variable
 - c qualitative and quantitative observations
 - d a newspaper article and a journal article
- 13 **Compare** an aim and a hypothesis.
- 14 The following types of information could be collected in an experiment. **Classify** each as either quantitative or qualitative data.

a colour	f force
b mass	g texture
c smell	h length
d time	i current
e weight	j temperature

- 15 **Discuss** the purpose and contents of a discussion in an experimental report.
- 16 **Classify** the following as either open or closed questions.
 - a Is it possible to reduce friction using oil?
 - b Is the average weight of boys in your class greater than the average weight of girls?
 - c Which type of material is best for making a shopping bag?
 - d What is the best colour for a flashing light so that it can be seen easily at night?
 - e Is it further to Mars than to Venus?
 - f How does the amount of sugar in water change the boiling temperature?

Creating

- 18 You have been asked to design an experiment to test the amount of light that can pass through different types of glass. You have the following equipment available: different glass samples including transparent, opaque, translucent and coloured; a light sensor and data logger; torch; ruler.
 - a **Construct** an aim for this experiment.
 - b **Construct** a hypothesis.
 - c **Identify** the independent and dependent variables.
 - d **List** the variable(s) that would need to be controlled.
 - e **Outline** any observations you would make.
 - f **Outline** any measurements you would make.
 - g **Propose** a method for this experiment.
 - h **Design** a table in which you could record your results.
- 19 Marika completed an experiment to test the effect of fertiliser on the growth of plants, using the equipment shown in Figure 9.2.6.
 - a **Identify** the independent variable.
 - b **Identify** the dependent variable.
 - c **List** the controlled variables.
 - d **Propose** a hypothesis for this experiment.

	Amount of fertiliser (grams)		Height of plant (cm)			
	Start	Day 2	Day 4	Day 6	Day 8	Day 10
0	5.0	6.0	6.5	6.5	6.5	6.5
5	5.0	6.5	8.6	10.5	12.8	14.7
10	5.0	6.4	8.2	9.2	11.0	12.1

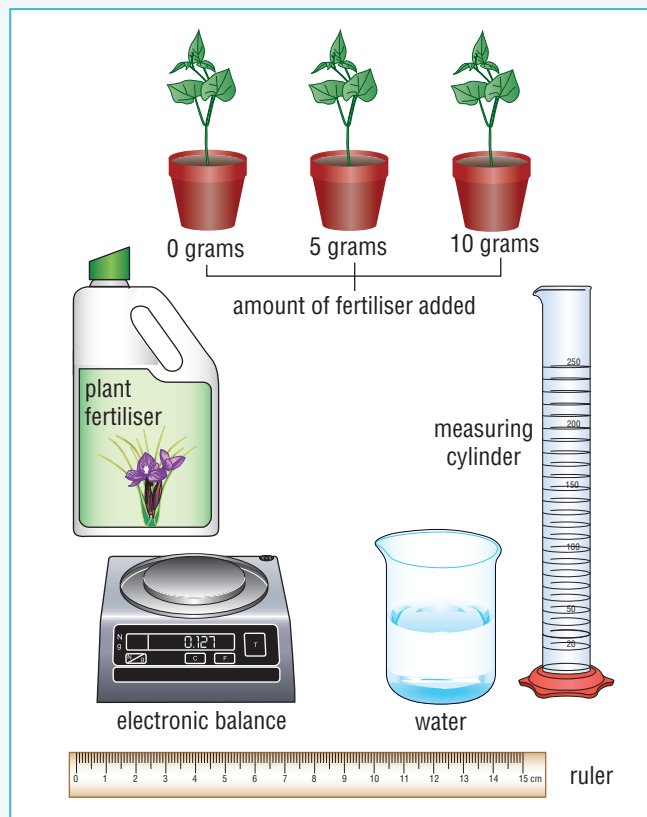

Fig 9.2.6

Marika recorded the results shown in the table above.

- e **Construct** a line graph to show these results. You will need three lines on the one graph. **N**
- f **Describe** any patterns and trends that you see in the results.
- g **Use** these results to deduce what effect the fertiliser had on the height of the plants.
- h Could you rely on these results, or believe any conclusion based on them? **Justify** your answer.
- i **Evaluate** the experiment to decide if it is a fair test.
- j **Propose** any improvements to the experiment.

CHAPTER REVIEW

Remembering

- 1 Recall** the skills required for carrying out an independent investigation by completing the following sentences with these words:

communicate, timelines, conduct, data, identifying, evaluate, safely, creative, scientific, mentor, solving, alone

When completing an independent investigation you will need to set suitable _____. You will need to work _____ while you design, _____ and _____ your investigation.

As problems arise you may need to apply _____ thinking and problem-_____ techniques. This will involve _____ problems and coming up with _____ solutions to them. Having a _____ to support you through difficult times can help when working _____. After completing an investigation it is necessary to _____ information and results to others. This will involve presenting _____ and information in suitable forms.

- 2 State** whether the following statements are true or false.

- a** The topic you select for investigation should not pose a danger to people or the environment.
- b** A closed question cannot be answered with a true/false or yes/no.
- c** A conclusion sums up the results of an investigation.
- d** An aim and a hypothesis are the same thing and only one of them should be included in a report of an investigation.
- e** A graph of results would appear in the conclusion of an investigation.

Understanding

- 3 Outline** three personal characteristics needed for working independently.
- 4 Copy** and complete the table to **summarise** the structure of a scientific report.
- 5 Explain** the difference between an investigation to **demonstrate** a scientific principle and an investigation into an aspect of science of your choice.

Report section	Purpose	Description of what should be included
Title	To identify the project and what it is about	A title
Aim		A statement about what you will be finding out
Hypothesis	A prediction or 'educated guess' about what you may find in an experiment	
Equipment		List of equipment and resources
Variables		
	To provide clear, unambiguous instructions that other scientists could follow to accurately repeat your experiment	
Results		
Discussion	To analyse and evaluate your results in detail	
		Whether you answered the aim. Whether the hypothesis was proved or disproved and why
Bibliography		Lists of resources including books, websites, journal articles etc.

Creating

- 6 Construct** three open-ended questions that may be suitable for investigation.
- 7** Peter decided to **investigate** the solubility of gases in water and apply the results to **explain** the El Niño effect. From texts and the internet, he found that marine animals depend on oxygen in the same way as animals on land. He also found that the gases oxygen and carbon dioxide are soluble in water.
- 8** Peter then used datalogging equipment to test the solubility of oxygen in water. His experiment produced the results shown below.
- a** Construct a line graph to display these results. You will need four lines on the one graph. **N**
- b Identify** any experimental results that may be wrong. **Predict** the correct values for these points.
- c Describe** any patterns and trends that you see in the results.

d Use these results to **deduce** how oxygen solubility is affected by temperature.

e Evaluate the experiment to decide whether it was a fair test.

- 9** Peter searched the internet to find information about the El Niño effect. His search allowed him to summarise the effect as follows:

‘On the west coast of the South American continent, a cool ocean current (called the Humboldt or Peru current) brings nutrient-rich water to the coast. This provides valuable food for the fish. But every two to seven years, at about Christmas time, a warm current comes and leaves the coastal fishermen with empty nets. The fishermen called this phenomenon “El Niño”, meaning “Christ Child”.’

Use the findings from Peter’s experiment to **propose** an explanation for the empty fishing nets.



Temperature °C	Tap water	Boiled tap water	Seawater	Boiled sea water
5	13.1	7.1	10.9	6.8
10	11.8	6.8	9.5	5.9
15	10.5	6.6	8.7	4.8
20	9.7	6.9	8.0	4.4
25	8.4	6.1	7.2	4.1
30	7.7	5.9	6.7	3.9
35	7.1	5.7	6.1	3.7
40	6.8	5.6	5.7	3.5



Sci Q Busters

Ask Sci Q Busters team

Breaking waves

Cockroach and nuclear blast

[Breaking waves](#)

[Cockroach and nuclear blast](#)

[Breaking fettuccine](#)

[Skippy to the rescue](#)



Breaking waves

Hi Q Busters,

I have a very simple question. Why do waves break?

Gary

REPLY

Hi Gary,

There is some very interesting science involved in the way waves behave.

Think of your normal beach where the water depth goes smoothly from deep water to shallow. As a wave moves into the shallow water, the bottom of the wave is slowed down by friction caused by the sandy bottom. This causes an increase in the wave's height. As the wave moves into even shallower water the wave begins to lean forward until the top gets ahead of its bottom and it topples over. Roughly a wave will start to break when it reaches a depth of 1.3 times the wave height.

It is just like when you are running and you trip over something on the beach. You suddenly lose balance and struggle to stay upright. If you don't regain your balance you fall quite a way from where you first tripped.

There are three main factors that make different types of waves:

- the type of swell
- the wind direction
- the slope of beach.

Ground swell waves are the best for giving good surfing. Their longer wavelength will move quickly into shallow water before starting to break. These breaking waves will be steeper and faster. Wind swell waves tend to break in deeper water and have less energy and tend to be much more crumbly.

Offshore wind makes for good waves. The wind blows against the top part of the wave and delays the top overtaking the bottom part—therefore the waves break later. They are easy to pick—just watch for the huge plumes of spray blowing back over the top of the wave. Onshore wind pushes the

top of the wave forward causing the wave to break before the normal breaking depth is reached.

A gently sloping sea floor makes crumbling waves that are not steep and lack energy. These are best for learning how to surf. The opposite of the gently sloping sea floor is a steep slope, gutter or a reef. Here a swell will approach at a greater speed. The waves created by this rapid change in depth are much steeper and more hollow. These are known as tube waves.

Hope this answers your question! We hope you catch a huge wave!

The Q Busters team



Cockroach and nuclear blast

Hi Q Busters

Our science teacher said that cockroaches will survive a nuclear war. Can this be true and if a nuclear war happens, will the Earth only be populated with cockroaches?

Thanks,

Adrian

REPLY

Hi Adrian

Many people say that cockroaches would survive a nuclear war. Here are some facts about cockroaches that may interest you.

- 1 They have outlasted the dinosaurs by about 150 million years, so they must be tough little things.
- 2 They can survive on only cellulose and even do a bit of cannibalism when the going gets tough.
- 3 They can survive without a head for a week or two—slightly gross!
- 4 So when a nuclear explosion occurs they can survive. They will tolerate up to 60 Gy. A Gy or Gray is the unit used to measure radiation absorption. Humans will be in great trouble at 4 to 10 Gy.

This might look impressive but cockroaches are only nuclear wimps. Let's look at some other organisms.

Wood-boring insects have survived doses of between 480 and 680 Gy and the humble fruit fly, believe it or not, survived 640 Gy. The wasp *Habrobracon* was still flying after an enormous 1800 Gy.

But there is a real heavyweight champion or 'king of radiation'. It's actually a bacterium that has the scientific name *Deinococcus radiodurans* meaning 'marvellous berry that withstands radiation'. It's been nicknamed Conan the Bacterium and can survive 15 000 Gy and twice this if it's frozen. Now that's impressive!

This organism lives in locations rich in rotted organic materials like animal dung, soil and here's the scary one—processed meat. It's also been found in dry, nutrient-poor areas like weathered rocks in Antarctica, dust and irradiated medical equipment.



Makes the cockroach seem almost loveable after a nuclear blast!

Happy cockroach hunting!

The Q Busters team

Sci Q Busters

Ask Sci Q Busters team

Breaking fettuccine

Skippy to the rescue

[Breaking waves](#)

[Cockroach and nuclear blast](#)

[Breaking fettuccine](#)

[Skippy to the rescue](#)



Breaking fettuccine

Dear Q Busters,

The other night mum asked me to break some more fettuccine to put into the pot. I did and some of the pasta broke into two pieces. But most of it broke into three or more pieces and they flew all over the kitchen. Is there an explanation for this and does it happen with all straight pasta?

Thanks Liana

Hi Liana

This is a puzzling one! You would think that by holding it at both ends and bending it, it would break into two bits. This rarely happens. It appears that the pasta first breaks at a point near the maximum bent point of the pasta. This break seems to happen at a defect point in the pasta. The other longer piece then snaps backwards as it's released from the tension and another break occurs at a different defect point.

This is a simple version of what happens. Two scientists actually wrote a research paper about this called 'Why spaghetti does not break in half' in 2005. They went on to win the 2006 Nobel Prize for Physics. They concluded that the pasta is broken up by flexural waves moving through the pasta.

They used Barilla no.1 dry spaghetti pasta of length 24.1 cm in their experiments. They used a

high-speed video to film each strand of pasta as it broke, capturing the details at 1000 frames per second.

The frames showed the initial break sends waves rippling down the length of the pasta. This wave increases the curvature of the already bent pasta, triggering many other breakages, which, in turn, trigger more waves, causing the strand to fragment.

Liana, as you can see it's a rather complicated application of forces. It is like when you break a dried stick. When it bends and finally snaps you feel the waves through your hand and again a few pieces of wood fly off.

Happy fettuccine snapping!

The Q Busters team

REPLY



Skippy to the rescue

Hi Q Busters,

The other day our class was looking at global issues and it seems that methane is more of a problem than carbon dioxide in global warming. I always thought that if we reduced the carbon dioxide all would be OK. Can you help me understand the role of methane in all of this?

Regards Crystal

REPLY

Hi Crystal,

Yes it is commonly thought that the biggest contributor to global warming is carbon dioxide. Forget coal-burning power stations and cars as the worst greenhouse gas emitters because what wanders around our paddocks are the really bad emitters. That's right—cows, sheep, goats and all other ruminants.

These ruminants have what is called a pregastric stomach or rumen where microbes digest plants and produce hydrogen, carbon dioxide and fatty acids. The hydrogen and carbon dioxide are of no use to the animal and microbes converting this into methane. This is released by the animal as a belch or fart.

Methane is worse than carbon dioxide because one tonne of methane has 25 times the global warming potential than a tonne of carbon dioxide. This is the

same as saying that one tonne of methane equals 25 tonnes of carbon dioxide.

Australia appears to be going in the direction of an emission-trading scheme (ETS), where you pay the government to allow you to pollute. The sheep and cattle industry will have problems if agriculture is included in the proposed ETS because of the high prices set on methane emissions.

So what can be done? Well we could stop eating meat products or move towards less emissions-intensive meat, such as chicken and pork. There's another better alternative—kangaroos.

Kangaroos don't emit methane, they emit acetone. It is estimated there are around 35 million kangaroos in Australia. Five of the 48 species of kangaroo are currently harvested for meat. Kangaroo meat is lean with around two per cent fat and very high levels of quality protein, iron and zinc. So, it is a healthier alternative.

Maybe you should get mum or dad to cook you up some kangaroo snags on the BBQ!

Happy BBQ-ing!

The Q Busters team



✕ — +

📧 📄 📧 📧 📧 📧 📧 📧

Subject

Got a question? Email the Sci Q Busters team at:
SciQBusters@pearson.com.au

Numbers in **bold** refer to key terms in **bold** type in the text

A

Aboriginal culture 58, 64, 122, 129–30, 194, 279, 313
 AC/DC *see* alternating current; direct current
 acceleration 205, 218–20, 231–2, 241–3
 acid rain 297
 acquired characteristics 170, 197
 Acquired Immune Deficiency Syndrome *see* AIDS
 acquired immunity 145
 action–reaction force pair 236
 activity (radioactive) 29
 activity series 18–19
 adaptations 167, 168–70
 behavioural 169
 functional 169
 physical or structural 169
 structural or physical 169
 adaptive radiation 176
 adult stem cells 325
 agent 131, 136
 AIDS 139, 149–51
 air resistance 242–3
 albinism 92, 155
 albino 92
 alcohol 161
 alcoholism 161
 alkaline 74
 alleles 84, 93
 allotransplants 327
 alloy 18, 38
 alpha particle (α) 1, 26
 alpha radiation 26, 28
 alternating current 262
 aluminium 38, 47, 48
 aluminium oxide 19
 AM *see* amplitude modulation
 amino acid 102
 amniocentesis 110
 amperes (A) 258
 amplitude 278
 amplitude modulation (AM) 281
 analogous structures 176
 analogue signals 287
 angina 158
 anorexia nervosa 125, 156
 antibiotics 105, 136, 147–8, 174
 resistance 148, 174

antibodies 145, 150
 antigen 93, 145
 arteriosclerosis 158
 asbestos 56, 104, 162
 automatic gain control 287
 average speed 207
Australopithecus 190

B

bacilli 136
 bacteria 136
 bakelite 56, 58
 balanced chemical equations 7–8
 balanced diet 123
 ball mill 46
 bandwidth 287
 base metal 38
 basic solution *see* alkaline
 battery 257
 Becquerel, Henri 25, 26
 Bell, Alexander Graham 286, 287
 benches (mining) 45, 46
 benign growth 158
 beta particle (β) 1, 26
 beta radiation 26–7
 Big Bang 196
 binary numbers 288
 bioaccumulation 317–19
 bioconcentration 317
 biodegradable 54, 58, 71
 biofuels 322
 biomagnified 317
 biopsy 158
 biotechnology 325–9
 bipedalism 190
 bitumen 70
 Black Death 135
 blast furnace 47
 blastocyst 326
 blood groups 93
 blow moulding 57
 blue–green algae 320
 bonding 5, 36, 70
 booster shot 147
 bubonic plague 135
 Buffon, Georges 197
 bulimia nervosa 125, 156
 bull roarer 279

C
 calcium oxide 8
 cancer 29, 30, 104, 122, 137, 146, 159, 279
 carat 38

carbon
 chemistry *see* organic chemistry
 dating 31
 fibre 65
 carbon dioxide 299, 302–3
 carbon-14 31
 carbuncle 145
 carcinogens 159, 319
 cast iron 38
 catalyst 10
 see also enzymes
 catalytic converter 10
 cat gut 64
 cell 257
 cells (mobile phone region) 287
 cellulose 63
 Cerenkov radiation 25
 CFCs 301
 chain reaction 310
 change 2–3
 changes of state 2
 chemical 2–3
 nuclear 3
 physical 2
 charge 258
 chemical equations 6–8
 respiration 9
 subscripts 8
 chemical reactions 2–10, 3, 16–19
 nuclear 25–31
 oxidation 16–19
 reaction rates 8–10, 17
 temperature 8
 see also chemical equations
 Chernobyl 311–12
 chlorofluorocarbons *see* CFCs
 chlorophyll 92
 chromatography 116
 chromosomes 79, 82, 95
 chronic alcohol abuse 161
 circuits 257, 260
 components 257
 parallel 260
 series 260
 clean coal 295
 cloning 110–11, 112, 328–9
 coaxial cables 288
 cocci 136
 codominance 85, 93
 codons 102
 coherent light 288
 coir 64
 coke 47

- combustion 1, 16–17
communications 286–9
compass 266
complementary base pairs 101, 102
complete combustion 16
compression waves 277
concentrated 9
concentration 9
Concorde 65
conditioner 74
conducting path 257
conductor (electrical) 37
conductor (heat) 37
contagious diseases 144
continuous variation 94
convergent evolution 176
coronary heart disease 158
corrosion 1, 16–19, 17
 protection 18–19
 see also oxidation
cosmic radiation 28
covalent bonding 5
crash testing 226, 232
creation stories 200
Cro-Magnons 192
cross-linking 56
crystal lattice 5, 6, 36
cultural evolution 194
cumulative poisons 162
Curie, Marie and Pierre 26
current 256, 258, 262
 alternating current 262
 direct current 262
- D**
Darwin, Charles 197, 198–9
Darwin, Erasmus 197
dataloggers 208
daughter nuclei 26
DDT 319
debate *see* scientific debate
decelerating 218
deep vein thrombosis 157
demodulation 288
deoxyribonucleic acid *see* DNA
depressant 161
depression 125, 163
diabetes 109, 132
diamond 69
dietary fibre 124
diffraction 281
digital signals 287
dilute 9
dioxins 319
diploid 82
direct current 262
direct transmission 144
dirty bomb 31
- discontinuous variation 94
disease 131–2, 135–40, 155–63
 artificial control 146–8
 contagious 144
 genetic 155
 infectious 135–40, 144
 natural control 144–5
 non-infectious 155–63
 transmission 144–8, 150
dispersion 288
displacement 205, 206
distance 205, 206
distance–time graphs 209
divergent evolution 175
DNA 70, 79, 81, 101–5, 108, 137,
 149, 185, 327
 see also recombinant DNA; RNA
DNA fingerprinting 110, 115–16
Dolly the sheep 112, 328
dominant
 gene 84, 92
 trait 81
dosimeters 29
double helix 101
Down syndrome 104, 155
drawn (metal) 37
drugs 159–61
 psychoactive 159
drycleaners 73
Dryopithecus 190
ductile 37
dynamo 270
- E**
Ebola 132, 135
efficiency 249
egg cells *see* ova
elastic potential energy 248–9
electric
 field 278
 generator 269
 motor 269
electrical conductor 37
electricity 257–71
electrolysis 46
electrolytes 156
electromagnet 267–8
electromagnetic
 spectrum 256, 279–81
 waves 277–81, 278, 299
El Niño effect 305
electromagnetism 266–71, 286
electron gun 269
electrophoresis 116
elements 3
 native 43
 stable 43
 unreactive 43
- Elephantiasis 140
embolism 157
embryo 184
embryonic stem cell 325
emulsion 74
endemic 132
energy 123, 124, 247–9
energy source 257, 314
energy user *see* load
environment 80
enzymes 10, 103, 109, 115
 see also catalysts
epidemic 132
esterification 35
ethics 296, 329
evolution 167–201, 170
exercise 125
extraction (of metal from ore) 46–7
extrusion 63
extrusion moulding 57
- F**
fabric softeners 74
Faraday, Michael 269
FDM *see* frequency division
 multiplexing
fibreglass 66
fibres 63–6, 74
 carbon 65
 glass 66
 natural 64
 silk 66
 synthetic 63
 wood 63
field lines 266
fission 1, 294, 309, 310
flatworm 139
flukes 139, 140
FM *see* frequency modulation
fomites 137
food irradiation 31, 296
force 205, 224, 231, 236–8
 action–reaction 236–8
 gravity 241–3
 types of 224
formula equation 6
fossil fuels 69, 70, 294, 297, 301
fossilisation 182
fossils 180–83
fractional distillation 70
frequency 278
frequency division multiplexing (FDM)
 287
frequency modulation (FM) 281
friction 224, 268
froth flotation 46
fungi 135, 139
fusion 1, 294, 314

G

Galilei, Galileo 241
galvanised iron 18
gametes 81, 82
gamma radiation 27–8, 31
gamma ray (γ) 1, 27, 30, 103, 279
gangrene 136
gangué 46
Geiger counter 29, 279
gender 95, 146, 161
gene
 cell therapy 111
 dominant 84
 duplication 185
 expression 103
 probe 116
 recessive 84
 technology 108, 109, 110, 112, 320
generator 269–70
genes 79, 81, 84
genetic
 code 185
 disorders 95–6, 104
 engineering 108, 109, 112
 map 112
genetically modified (GM) 108, 112, 295, 320–22
geneticist 86
genetics 79–117, 80, 94, 108–12
 controlling 108–12
 disorders 95–6, 104
 risks 112
 variation 94, 105, 108, 170
genotype 84–6, 93, 95
 heterozygous 84–6, 93
 homozygous 84–6, 93
geocentric model 196
geosequestration 295
g-force 242
glass fibre 66
global
 climate change *see* global warming
 issues 294–329
 warming 196, 295, 296, 299–305, 300
glycemic index (GI) 125
GMO (genetically modified organism) 320
gold 43, 46, 47, 48
Gondwana 185
gradient 209
gravitational potential energy 248
gravity 196, 241–3
greenhouse
 effect 299
 gases 296, 299, 300–302

H

haemoglobin 103, 185
haemophilia 95, 96, 111, 132, 155
haemorrhage 157
hafting 58
half-life 27, 28
hangover 161
haploid 82
hard water 74
health 123–5
health and disease 122–63
heat conductor 39
heliocentric model 196
herbicides 319
heredity 80
hertz (Hz) 278
heterozygous 84–6, 93
HIV 135, 149
hominoids 190
Homo erectus 191
Homo habilis 191
Homo neanderthalensis 192
Homo sapiens 189
homologous pair 82
homologous structures 183
homozygous 84–6, 93
host 131
human evolution 189–94
human genome project 112
Human Immunodeficiency Virus *see* HIV
hydrocarbons 70–71
hydrogen cars 296
hydrophilic 74
hydrophobic 74
hypertension 158

I

Ig Nobel Prize 324
immune 145
immune system 145
immunity 147
 acquired 145
 active 147
 passive 147
incoherent light 289
incomplete combustion 17
incomplete dominance 86
indirect transmission 144
individual research project 331–41
Industrial Revolution 173, 300
inertia 225, 226
infection 131
infectious 131
infectious disease 144
infra-red (IR) rays 280
inheritance 80–86, 93, 103
 codominance 85, 93
 complex 86

human 92–6
 incomplete dominance 86
 other 93
 simple 84

inherited characteristics 170
injection moulding 57
inorganic 70
instantaneous speed 207
insulin 156
intelligent design 201
in-vitro fertilisation (IVF) 327
ionic bonding 6
ionise 28, 29
ionising radiation 28
ions 28–9, 46
iron 38, 47
isotopes 25

J

Jenner, Edward 147
joules 123, 247

K

Kevlar 65
key outcomes 1, 35, 79, 122, 167, 205, 256, 294, 331
kinetic energy 248
kooladoo 279
Kyoto Protocol 302

L

laboratory assistant 343
Lamarck, Jean Baptiste 197
lasers 288–9
Law of Conservation of Mass 8
lead 318
Legionnaire's disease 132
leucocytes 144, 149
leukemia 26, 29
light waves *see* electromagnetic waves
limelight 8
Lister, Joseph 148
load 257
longitudinal waves 277

M

macroscopic 139
Maglev train 268
magnetic fields 266–71, 278, 314
magnets 266–9
malignant growth 158
malleable 37
Maralinga 313
Marconi, Guglielmo 281
mass 231, 241
mass number 26
materials 35–78, 36, 249
medical laboratory technician 96
meiosis 79, 83, 104

- melanoma 159
Mendel, Gregor 80, 84
mental illness 163
mercury 297, 318
metabolism 124
metal oxide 17, 43, 45
metals 36–9, 43–8
 minerals 44
 percentage in Earth's crust 43, 48
 properties 37
 pure metal 38, 43, 46
 scarce 47, 48
metastases 159
metastasis 159
methane 70, 301
methyl mercury 318
microbe *see* micro-organism
micro-organism 131
microphones 270
microsieverts (μSv) 29
microwaves 281, 287, 289
mild steel 38
minerals (nutrients) 124, 155
minerals (rocks) 44
mines (underground) 45
mining 43–8
 open-cut 45
 pollution from 44, 46
mitosis 79, 83
mobile phone 287
modem 288
modulation 281, 288
molecule, polar 73
monitors 269
monofilaments 65
monomers 56
mosquito 139, 140, 144, 174
motion 205–49
mutagens 103–4, 122, 155
mutation 103–4, 122, 138, 155
myxomatosis 173–4
- N**
native elements 43
natural fibres 63
natural selection 167, 172–3, 196, 197
negative acceleration 218
neo-Darwinism 200
Newton's Laws of Motion 205, 224–6
 Newton's First Law 224–6
 Newton's Second Law 231–2
 Newton's Third Law 236–8
nitrogen bases 101
nitrous oxide 301
non-renewable resources 48
nuclear
 bomb 310
 change 3
 energy 279
 fission 26
 fusion 314
 force 25
 medicine 30
 power 295, 297, 309–14
 reactions 25–31
 reactor 311
 waste disposal 312
nuclear radiation 25–31, 103
 alpha radiation 26
 beta radiation 26–7
 gamma radiation 27
 half-life 27, 28
 measuring 29
 radioactive decay 26
 sources 28
 uses 30–31
nugget 43
nutrients 123
- O**
Ohm's Law 256, 261
ohms (Ω) 258
oil 58, 70, 74
opportunistic infections 150
opportunistic pathogens 139
optic fibres 288
ore 44, 45, 46
organic
 chemistry 69–71
 compounds 54
 solvents 73
organism 131
outbreak 132
ova 79, 81, 82, 103
overburden 45
oxidation 16–19
 see also corrosion
oxides 43
- P**
palaeontology 180
pandemic 132, 138
paraffin wax 70
parallel circuits 260
parallel evolution 177
parasite 131
parent nucleus 26
pathogen 131, 135, 139
pathologist 131
pathology 131
pedigree 94, 96
pentadactyl limb 183–4
periodic table 4
pesticides 319
phenotype 84, 93
photochemical smog 301
photography 25, 208, 209
 high-speed composite 209
 multi-flash 208
physical change 2
plasmids 109
plastics 54–8, 63, 65, 71
 monofilaments 65
 moulding 57
 polymerisation 56
 properties 54, 56
 recycling 58
 thermoplastic 56–8, 63, 65
 thermosetting 56
 type and uses 55
polio 146, 149
pollen 81
pollution 44, 46, 71, 103–4, 132, 297,
 313, 317–20, 321
 food chain 317–20
 mining 44, 46
 plastics 54, 71
 radioactivity 103–4, 313
polymerase chain reaction (PCR) 116
polymerisation 56
polymers 54, 56
 carbon-based 54
 inorganic 56
permanent magnet 268
potential difference 258
potential energy 248–9
power transmission 271
precipitate 3
primates 189
products 6, 8
propellant 237
proteins 102
protists 139
protozoa 139
PSP toxin 320
psychosomatic illness 125
Punnett square 85, 92, 93
pure metal 38, 43, 46
pus 144, 145, 147
- R**
radiation *see* nuclear radiation
radiation sickness 29
radio 281
radio waves 281
radioactive 25, 279, 309–14
radioactive decay 26
radioactive tracers 30
radioisotopes 26
radiotherapy 30, 279
radon gas 28
Ramapithecus 190
Rasputin 96
reactants 6, 8

reaction
 engine 237
 time 210
reactions 1–34
recessive
 gene 84, 92, 95
 trait 81
recombinant DNA 109
recycling 48, 58
refined 70
replication 102
reproduction (sexual) 83
resins 58
resistance 256, 258
resistors 258
respiration 9
restriction enzymes 115
retrovirus 149
Rh negative 93
Rh positive 93
Rhesus factor 93
rhizomes 64
right-hand rule 267, 268
RNA 137
rocket engines 237–8
rubella 146
rust 17, 38

S

sacrificial protection 18
saponification 35, 74
scientific debate 295–7, 313–14
scientific evidence 295–6, 303, 328
scurvy 124
selective breeding 108, 320
series circuits 260
sex cells 82, 83
sex-linked 95
shampoo 74
shellac 58
shingles 138
short-wave radio waves *see* microwaves
sickle-cell anaemia 104
sieverts (Sv) 29
silk 66
slag 45
smallpox 135, 147
smelting 47
smoke detectors 31
smoking 161
soap 73–4
soft water 74
solar radiation 28
solenoid 266
speakers 268
speciation 174–5
species 174
speed 205, 207, 219, 256, 278

 electromagnetic wave 256, 278
 speed–time graphs 210, 220
 sperm 79, 81, 82, 95, 103
 spinneret 65
 spirilla 136
 spring constant 249
 steel 18, 38
 mild 38
 stainless 18, 38
 tool 38
 stem cells 111, 295, 325–9
 adult 325
 Stolen Generation 129
 stroke 157
 superconductors 268
 surface area 10
 surface ozone 301
 surfactants 73–4
 survival of the fittest 198, 199
 sustainability 35
 switchboard 287
 symbols and formulae 3–6, 207, 232,
 242, 258
 synthetic fibres 63

T

tapeworm 139
TDM *see* time division multiplexing
telegraph 286
telephone 287
tendons 64
terminal velocity 242–3
terrestrial radiation 28
tetra-ethyl lead 318
theories 196–201
therapeutic cloning 111
thermoplastics 56–8, 63, 65
 moulding 57
 resins 58
thermosetting 56
thrombosis 157
thrombus 157
thrust 237
ticker-timers 209
time division multiplexing (TDM) 287
Tinea 139
tool steel 38
toxin 317, 319
traditional medicine 130
traffic lights 271
traits 81
 dominant 81
 recessive 81
thrush 136, 139, 150
transformers 271
transgenic 110
transitional forms 183
transverse waves 277

Tri-21 *see* Down syndrome
triple bottom line 296
true-breeding 81
tumour 29, 155, 158
turbines 270
TV 269

U

ultraviolet (UV) radiation 280
uranium 309, 310, 313

V

vaccinated 146
vaccines 146
vacuum 278
vector 131, 144
vein 43
velocity 207, 208, 231, 242–3
 terminal 242–3
vending machines 270–71
vestigial organs 184
virulence 131
viruses 137–8, 147, 149, 173
visible spectrum 279
 see also electromagnetic spectrum
vitamins 124, 155
voltage 256, 258
volts (V) 258

W

Wallace, Alfred Russel
water 74
Watson–Crick model 102
wavelength (λ) 278
 long 299
 short 299
waves (electromagnetic) 256, 277–81
weight 242
weightlessness 243
whale blubber 74
white blood cells *see* leucocytes
wood fibres 63
word equation 1, 6
work 247
World Wide Web (WWW) 288

X

X chromosome 95
xenotransplant 327
xenotransplantation 295, 327
X-linked *see* sex-linked
X-rays 27, 103, 162, 280

Y

Y chromosome 95

Z

zeolite 74
zygote 82–3, 325